

2.0	RIDUTTORI EPICICLOIDALI SERIE EP	PLANETARY GEARBOXES EP SERIES	PLANETENGETRIEBE SERIE EP	
2.1	Caratteristiche	<i>Characteristics</i>	Merkmale	30
2.2	Designazione	<i>Designation</i>	Bezeichnung	31
2.3	Selezione	<i>Selection</i>	Getriebeauswahl	31
2.4	Gioco angolare	<i>Backlash</i>	Spiel	31
2.5	Carichi radiali e assiali su albero lento	<i>Radial and axial loads on output shaft</i>	Radial-und Axiallasten an der Ausgangswelle	32
2.6	Lubrificazione	<i>Lubrication</i>	Schmierung	32
2.7	Momento d'inerzia	<i>Moment of inertia</i>	Trägheitsmoment	33
2.8	Dati tecnici	<i>Technical data</i>	Technische Daten	36
2.9	Dimensioni	<i>Dimensions</i>	Abmessungen	36
2.10	Istruzioni per il montaggio del motore	<i>Instructions for the motor assem- bling</i>	Anleitung für Motoranbau	46



2.1 Caratteristiche

La serie di riduttori epicicloidali EP è il risultato di un ottimo rapporto tra economicità del prezzo e garanzia di precisione delle caratteristiche di funzionamento. I nostri riduttori sono stati realizzati per un'utilizzo prevalente sulle seguenti applicazioni:

- Macchine utensili
- Macchine per la lavorazione del legno
- Linee transfer
- Macchine da stampa
- Macchine automatiche per confezionamento ed imballaggio
- Automazioni
- Manipolatori
- Macchine serigrafiche
- Guide lineari

La gamma dei riduttori è costituita da 5 grandezze (55, 75, 90, 120 e 155), a 1 e 2 stadi di riduzione, ognuna con due tipi di alberi uscita (tipo A e tipo T) e flange uscita di tipo A, T e Q.

Corpo: costruito in acciaio, garantisce robustezza e una elevata affidabilità nel tempo.

Flange: le flange in entrata ed in uscita sono costruite in alluminio e sono disponibili in molteplici varianti costruttive.

Alberi: sono costruiti in acciaio legato bonificato.

Ingranaggi: in acciaio legato da cementazione e tempra, con dentature rettificata.

Cuscinetti: di elevata qualità opportunamente dimensionati per garantire elevate durate e silenziosità di funzionamento.

2.1 Characteristics

The planetary gearbox EP series is the result of the outstanding ratio competitive price / precision guaranteed with regard to operating features.

Our gearboxes are manufactured for prevailing utilization in the following applications:

- *Machine tools*
- *Woodworking machines*
- *Transfer machines*
- *Printing machines*
- *Automatic packing and packaging machines*
- *Automation*
- *Mechanical hands*
- *Silk-screen process machines*
- *Linear guides*

The EP series is available in 5 sizes (55, 75, 90, 120 and 155), with 1 or 2 reduction stages, with two types of output shaft (A and T) and three types of output flange (A, T and Q).

Housing: *made of special nitrided steel to assure strength, high reliability and long life.*

Flanges: *input and output flanges made of aluminium and available in several versions.*

Shafts: *made of hardened and tempered alloy steel.*

Gears: *made of casehardened and tempered alloy steel, with ground toothing.*

Bearings: *high quality and suitably sized to assure long life and noiseless working.*

2.1 Merkmale

Die EP Serie von Planetengetrieben ist das Ergebnis des hervorragenden Verhältnis guten Preis / garantierte Präzision der Betriebseigenschaften.

Unsere Getriebe sind für überwiegende Verwendung in der folgenden Applikationen hergestellt:

- Werkzeugmaschinen
- Holzbearbeitungsmaschinen
- Transfermaschinen
- Druckmaschinen
- Automatische Verpackungsmaschinen
- Automation
- Manipulatoren
- Siebdruckmaschinen
- Linearführungen

Die EP Serie ist in 5 Größen (55, 75, 90, 120 und 155) mit 1 oder 2 Untersetzungsstufen, mit zwei Typen von Abtriebswellen (A und T) und drei Typen von Abtriebsflanschen (A, T und Q) verfügbar.

Gehäuse: aus Spezial-Nitrierstahl. Garantiert Robustheit und dauerhaft hohe Zuverlässigkeit.

Ein- u. Ausgangsflansche: aus Aluminium, in zahlreichen Varianten lieferbar.

Wellen: aus vergütetem Legierungsstahl.

Zahnräder: aus Einsatzstahl mit geschliffenen Zahnflanken.

Lager: sind hochwertig und zweckmäßig bemessen, um eine lange Lebensdauer und einen geräuscharmen Lauf zu garantieren.

2.2 Designazione

2.2 Designation

2.2 Bezeichnung

Riduttore epicicloidale Planetary gearbox Planetengetriebe	Grandezza Size Größe	Numero di stadi Steps Unteretzungsstufen	Coassiale Coaxial Koaxial	Rapporto di riduzione Ratio Unteretzungsverhältnis	Albero uscita Output shaft Durchmesser Abtriebswelle	Flangia uscita Output flange Ausgangsfiansch	Albero entrata Input shaft Durchmesser Eingangswelle	Flangia in entrata Input flange Eingangsfiansch	Posizione di montaggio Mounting position Baulage
EP	55	2	C	100	A	A	AE..	P..	B5
	55 75 90 120 155	1 2	C	3 - 100	A T	A T Q	Vedi tabelle See tables Siehe Tab.	Vedi tabelle See tables Siehe Tab.	B5 V1 V3 OS

2.3 Selezione

2.3 Selection

2.3 Getriebeauswahl

Per la selezione dei riduttori epicicloidali EP, seguire la procedura descritta al paragrafo a pag. 6.

Make the selection of the planetary gearboxes EP Series as described at paragraph page 6.

Die Wahl der Planetengetriebe Serie EP wird wie im Abschnitt Seite 6.

2.4 Gioco angolare (α_{max})

2.4 Backlash (α_{max})

2.4 Spiel (α_{max})

Gioco massimo [arcmin] misurato sull'albero uscita, con albero entrata bloccato applicando una coppia pari al 2% della coppia nominale.

Max. backlash measured on output shaft by torque equals to 2% of the nominal torque value with input shaft blocked.

Maximales Spiel [arcmin], gemessen an der Abtriebswelle bei blockierter Eingangswelle mit 2% des Nennmoments.

2.5 Carichi radiali e assiali su albero lento

Nella tabella delle prestazioni sono indicati i valori, espressi in N, dei carichi assiali e radiali ammissibili alle diverse velocità per una durata dei cuscinetti di 20.000 ore. Il carico radiale F_{R2} si considera applicato ad una distanza dalla battuta pari alla metà della lunghezza dell'albero lento. Per distanze y diverse, è possibile calcolare il nuovo carico massimo ammissibile F_{R2Y} utilizzando formula e coefficienti indicati nella tabella.

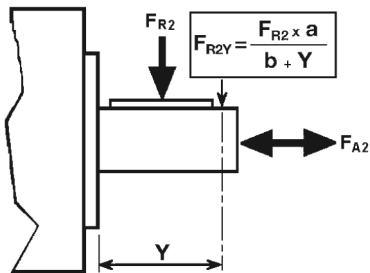

2.5 Radial and axial loads on output shaft

The table of performances shows admissible axial and radial load values expressed in N for different speeds and for a bearing life of 20.000 hours. Radial load F_{R2} calculations have been based on loads applied to the center line of the output shaft extension. For different y distance it is possible to calculate the new maximum admissible load by using formula and coefficient shown in the table.

2.5 Radial-und Axiallasten an der Abtriebswelle

Die Leistungstabelle enthält die in N ausgedrückten Werte der Axial- und Radiallasten für verschiedene Umdrehungszahlen. Diesen Werten liegt eine Lebensdauer der Lager von 20.000 Stunden zugrunde. Die Radiallast F_{R2} greift hierbei auf der Mitte der Abtriebswelle an. Greift die Radiallast an einem anderen Punkt der Abtriebswelle an, so kann man die zulässige Radiallast mit der folgenden Formel sowie den dazugehörigen Koeffizienten berechnen:

	EP 55	EP 75	EP 90	EP 120	EP 155
a	27	46	56	77	95
b	18	32	39	52	64

2.6 Lubrificazione

I riduttori EP sono forniti completi di lubrificante a vita pertanto non necessitano di manutenzione. In fase di ordine specificare la posizione di montaggio.

2.6 Lubrication

EP gearboxes are supplied filled with long-life lubricant and do not require any maintenance. When ordering it is important to specify the exact mounting position.

2.6 Schmierung

Die Planetengetriebe EP werden inklusive Dauerschmierung geliefert und sind wartungsfrei. Bei der Bestellung bitte die Einbauposition angeben.

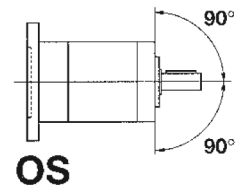
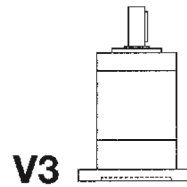
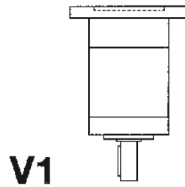
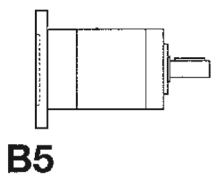

2.7 Momento d'inerzia J
[kg·cm²]

2.7 Moment of inertia J
[kg·cm²]

2.7 Trägheitsmoment J
[kg·cm²]

EP 55								
Albero entrata / Input shaft / Antriebswelle								
Stadi Steps Stufenzahl	i	6	6.35	7	8	9	9.525	11
1	3	0.07	0.07	0.07	0.09	0.09	0.09	0.09
	4	0.06	0.06	0.06	0.08	0.08	0.08	0.08
	5	0.06	0.06	0.06	0.07	0.07	0.07	0.08
	7	0.06	0.06	0.06	0.07	0.07	0.07	0.07
	10	0.05	0.05	0.05	0.07	0.07	0.07	0.07
2	9	0.07	0.07	0.07	0.09	0.09	0.09	0.09
	12	0.07	0.07	0.07	0.09	0.09	0.09	0.09
	15	0.07	0.07	0.07	0.09	0.09	0.09	0.09
	16	0.06	0.06	0.06	0.08	0.08	0.08	0.08
	20	0.06	0.06	0.06	0.08	0.08	0.07	0.08
	25	0.06	0.06	0.06	0.07	0.07	0.07	0.08
	28	0.06	0.06	0.06	0.07	0.07	0.07	0.07
	35	0.06	0.06	0.06	0.07	0.07	0.07	0.07
	40	0.05	0.05	0.05	0.07	0.07	0.07	0.07
	50	0.05	0.05	0.05	0.07	0.07	0.07	0.07
	70	0.05	0.05	0.05	0.07	0.07	0.07	0.07
	100	0.05	0.05	0.05	0.07	0.07	0.07	0.07

EP 75											
Albero entrata / Input shaft / Antriebswelle											
Stadi Steps Stufenzahl	i	6	6.35	7	8	9	9.525	11	12	12.7	14
1	3	0.17	0.17	0.17	0.18	0.18	0.18	0.20	0.20	0.20	0.22
	4	0.12	0.12	0.12	0.13	0.13	0.13	0.14	0.15	0.14	0.16
	5	0.11	0.11	0.11	0.12	0.12	0.12	0.13	0.14	0.13	0.15
	7	0.09	0.09	0.09	0.11	0.11	0.11	0.12	0.12	0.12	0.14
	10	0.09	0.09	0.09	0.10	0.10	0.10	0.11	0.12	0.11	0.13
2	9	0.16	0.16	0.16	0.17	0.17	0.17	0.19	0.19	0.19	0.21
	12	0.16	0.16	0.16	0.17	0.17	0.17	0.18	0.18	0.18	0.20
	15	0.15	0.15	0.15	0.17	0.17	0.17	0.18	0.18	0.18	0.20
	16	0.12	0.12	0.12	0.13	0.13	0.13	0.14	0.15	0.14	0.16
	20	0.12	0.12	0.12	0.13	0.13	0.13	0.14	0.14	0.14	0.16
	25	0.10	0.10	0.10	0.12	0.12	0.12	0.13	0.13	0.13	0.15
	28	0.09	0.09	0.09	0.11	0.11	0.11	0.12	0.12	0.12	0.14
	35	0.09	0.09	0.09	0.11	0.11	0.11	0.12	0.12	0.12	0.14
	40	0.09	0.09	0.09	0.10	0.10	0.10	0.11	0.12	0.11	0.13
	50	0.09	0.09	0.09	0.10	0.10	0.10	0.11	0.12	0.11	0.13
	70	0.09	0.09	0.09	0.10	0.10	0.10	0.11	0.12	0.11	0.13
	100	0.09	0.09	0.09	0.10	0.10	0.10	0.11	0.12	0.11	0.13

I valori dei momenti d'inerzia riportati si riferiscono all'albero entrata.

The moment of inertia values refer to the input shaft.

Die Werte der Trägheitsmoment beziehen sich auf die Antriebswelle.

2.7 **Momento d'inerzia J**
[kg·cm²]

2.7 **Moment of inertia J**
[kg·cm²]

2.7 **Trägheitsmoment J**
[kg·cm²]

		EP 90									
		Albero entrata / <i>Input shaft</i> / Antriebswelle									
Stadi Steps Stufenzahl	i	9	9.525	11	12	12.7	14	15.87	16	19	
1	3	0.53	0.53	0.54	0.54	0.54	0.56	0.76	0.76	0.73	
	4	0.35	0.35	0.36	0.36	0.36	0.38	0.58	0.58	0.55	
	5	0.29	0.29	0.30	0.30	0.30	0.32	0.52	0.52	0.49	
	7	0.24	0.24	0.25	0.25	0.25	0.27	0.47	0.47	0.44	
	10	0.21	0.21	0.22	0.23	0.23	0.25	0.44	0.44	0.41	
2	9	0.53	0.53	0.54	0.55	0.55	0.56	0.76	0.76	0.73	
	12	0.51	0.51	0.52	0.53	0.53	0.55	0.74	0.74	0.71	
	15	0.51	0.51	0.52	0.52	0.52	0.54	0.74	0.74	0.70	
	16	0.34	0.34	0.35	0.35	0.35	0.37	0.57	0.57	0.54	
	20	0.34	0.34	0.35	0.35	0.35	0.37	0.57	0.57	0.53	
	25	0.28	0.28	0.29	0.29	0.29	0.31	0.51	0.51	0.48	
	28	0.24	0.23	0.24	0.25	0.25	0.27	0.46	0.46	0.43	
	35	0.23	0.23	0.24	0.25	0.25	0.27	0.46	0.46	0.43	
	40	0.21	0.21	0.22	0.23	0.23	0.24	0.44	0.44	0.41	
	50	0.21	0.21	0.22	0.23	0.22	0.24	0.44	0.44	0.41	
	70	0.21	0.21	0.22	0.23	0.22	0.24	0.44	0.44	0.41	
100	0.21	0.21	0.22	0.23	0.22	0.24	0.44	0.44	0.41		

		EP 120							
		Albero entrata / <i>Input shaft</i> / Antriebswelle							
Stadi Steps Stufenzahl	i	12.7	14	15.87	16	19	22	24	28
1	3	2.02	2.08	2.25	2.25	2.22	4.36	4.32	4.17
	4	1.13	1.19	1.36	1.36	1.33	3.47	3.43	3.28
	5	0.86	0.91	1.08	1.08	1.05	3.19	3.15	3.01
	7	0.62	0.68	0.85	0.85	0.82	2.96	2.92	2.77
	10	0.51	0.56	0.73	0.73	0.70	2.84	2.80	2.66
2	9	2.00	2.06	2.23	2.23	2.20	4.34	4.30	4.15
	12	1.92	1.97	2.14	2.14	2.11	4.26	4.22	4.07
	15	1.88	1.93	2.10	2.10	2.07	4.22	4.18	4.03
	16	1.07	1.13	1.30	1.30	1.27	3.41	3.37	3.22
	20	1.05	1.10	1.28	1.28	1.24	3.39	3.35	3.20
	25	0.80	0.86	1.03	1.03	0.99	3.14	3.10	2.95
	28	0.61	0.66	0.83	0.83	0.80	2.94	2.90	2.76
	35	0.60	0.65	0.82	0.82	0.79	2.94	2.90	2.75
	40	0.50	0.55	0.72	0.72	0.69	2.83	2.79	2.65
	50	0.49	0.55	0.72	0.72	0.68	2.83	2.79	2.64
	70	0.49	0.54	0.71	0.71	0.68	2.83	2.79	2.64
100	0.49	0.54	0.71	0.71	0.68	2.83	2.79	2.64	

I valori dei momenti d'inerzia riportati si riferiscono all'albero entrata.

The moment of inertia values refer to the input shaft.

Die Werte der Trägheitsmoment beziehen sich auf die Antriebswelle.

2.7 Momento d'inerzia J
[kg·cm²]

2.7 Moment of inertia J
[kg·cm²]

2.7 Trägheitsmoment J
[kg·cm²]

EP 155										
Albero entrata / Input shaft / Antriebswelle										
Stadi Steps Stufenzahl	i	15.87	16	19	22	24	28	32	35	38
1	3	6.97	6.97	7.01	8.24	8.21	12.21	14.05	13.92	13.59
	4	4.45	4.45	4.48	5.72	5.68	9.69	11.53	11.40	11.07
	5	3.57	3.57	3.60	4.84	4.80	8.80	10.64	10.51	10.19
	7	2.86	2.86	2.89	4.13	4.09	8.09	9.93	9.81	9.48
	10	2.49	2.49	2.52	3.76	3.72	7.73	9.57	9.44	9.11
2	9	6.84	6.84	6.87	8.11	8.07	12.07	13.91	13.79	13.46
	12	6.55	6.55	6.59	7.83	7.79	11.79	13.63	13.51	13.18
	15	6.46	6.46	6.49	7.73	7.69	11.70	13.54	13.41	13.08
	16	4.22	4.22	4.25	5.49	5.45	9.45	11.29	11.17	10.84
	20	4.16	4.16	4.19	5.43	5.40	9.40	11.24	11.11	10.78
	25	3.38	3.38	3.41	4.65	4.62	8.62	10.46	10.33	10.00
	28	2.78	2.78	2.81	4.05	4.02	8.02	9.86	9.73	9.40
	35	2.76	2.76	2.80	4.03	4.00	8.00	9.84	9.71	9.38
	40	2.45	2.45	2.48	3.72	3.69	7.69	9.53	9.40	9.07
	50	2.44	2.44	2.48	3.71	3.68	7.68	9.52	9.39	9.06
	70	2.44	2.44	2.47	3.71	3.67	7.67	9.51	9.39	9.06
100	2.43	2.43	2.46	3.70	3.67	7.67	9.51	9.38	9.05	

I valori dei momenti d'inerzia riportati si riferiscono all'albero entrata.

The moment of inertia values refer to the input shaft.

Die Werte der Trägheitsmoment beziehen sich auf die Antriebswelle.

EP 55																		Stadi Steps Stufenzahl	
Stadi Steps Stufenzahl	1					2												1	2
	i	3	4	5	7	10	9	12	15	16	20	25	28	35	40	50	70		
T _{2N}	12	14	16	12	10	14	16	16	16	16	16	16	16	16	16	14	12	n _{1nom}	4000
T _{2A}	22	24	24	22	20	24	28	28	28	28	28	28	28	28	28	24	22	n _{1max}	5000
T _{2S}	44	48	48	44	40	48	56	56	56	56	56	56	56	56	56	48	44	LpA	< 70
J	Vedi pag. 31 / See page 31 / Siehe auf Seite 31																	Lh	20000
R _t	1.0					0.9					1.0					0.9		F _{R2}	300
R _d	0.96					0.93												F _{A2}	450
Kg	0.8					1.8												α _{max}	8' 10'

F_{R2} Carico radiale nominale in uscita [N] a 100min⁻¹
 F_{A2} Carico assiale in uscita [N] a 100min⁻¹

Rated output radial load [N] at 100min⁻¹
 Output axial load [N] at 100min⁻¹

Nenn-Radiallast an der Abtriebswelle bei 100min⁻¹
 Axiallast an der Abtriebswelle bei 100min⁻¹

2.9 Dimensioni

2.9 Dimensions

2.9 Abmessungen

Dimensioni generali e uscite / General and output dimensions / General-und Abtriebsabmessungen

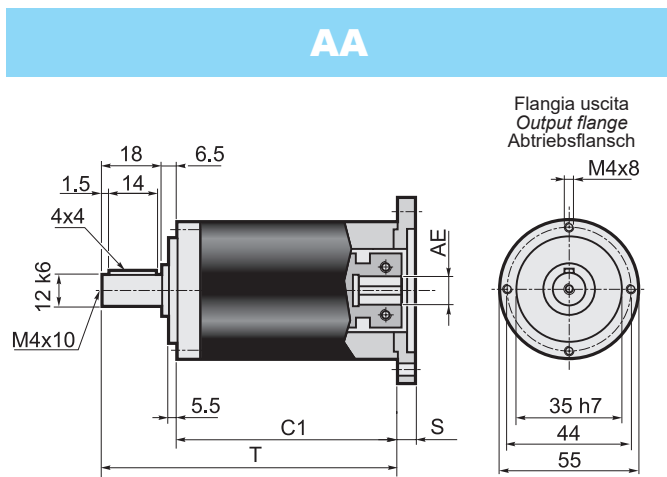

Stadi / Steps / Stufenzahl	1	2	AE= 6 - 6.35 - 7 - 8 - 9 - 9.52 - 11
C1	62.5	81.5	
T	87	106	

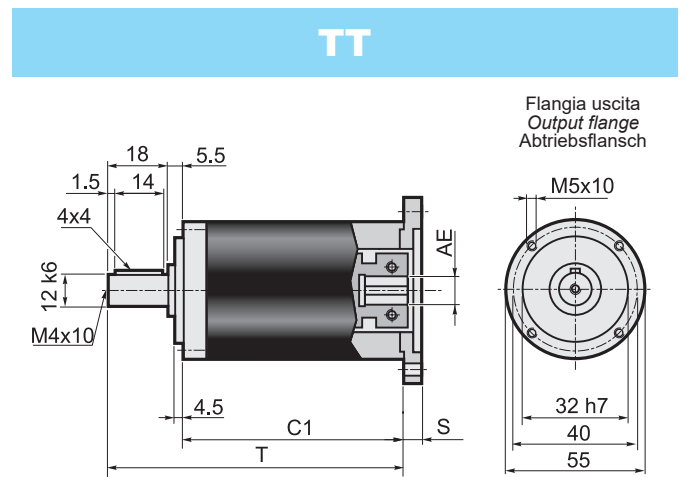

Stadi / Steps / Stufenzahl	1	2	AE= 6 - 6.35 - 7 - 8 - 9 - 9.52 - 11
C1	63.5	82.5	
T	87	106	

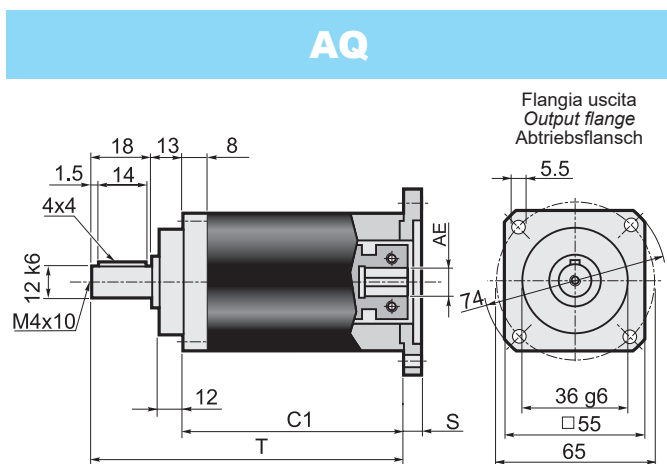

Stadi / Steps / Stufenzahl	1	2	AE= 6 - 6.35 - 7 - 8 - 9 - 9.52 - 11
C1	56	75	
T	87	106	

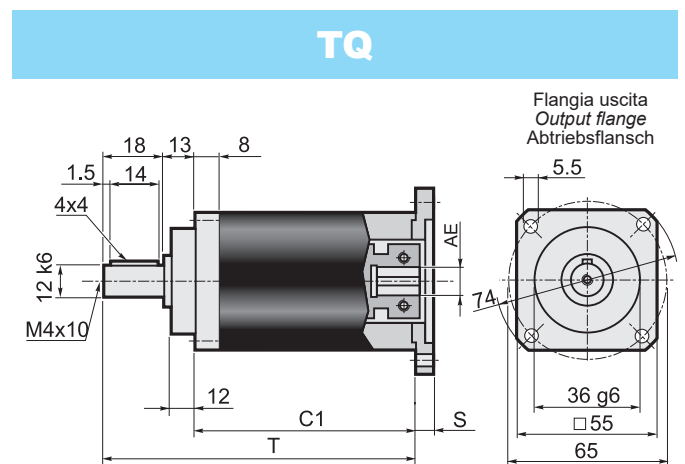

Stadi / Steps / Stufenzahl	1	2	AE= 6 - 6.35 - 7 - 8 - 9 - 9.52 - 11
C1	56	75	
T	87	106	

Dimensioni entrate / Input dimensions / Antriebsabmessungen

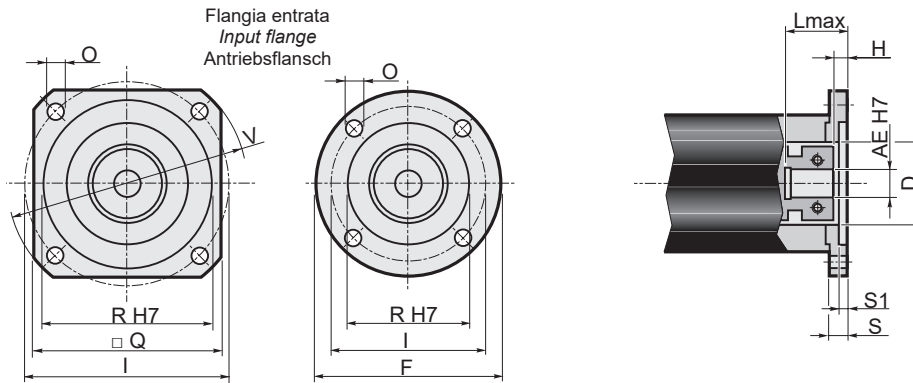

	Flange entrata / Input flange / Antriebsflansch									Albero entrata / Input shaft / Antriebswelle													
										AE													
	F	Q	V	I	R (H7)	O	S	S1	D	6		6.35		7		8		9		9.52		11	
									L _{max}	H	L _{max}	H	L _{max}	H	L _{max}	H	L _{max}	H	L _{max}	H	L _{max}	H	
P01*	60	=	=	43.82	22	4.5	10	3	22	30	7	30	7	30	7	30	7	30	7	30	7	30	7
P02*	=	60	80	66.67	38.1	5.5	10	3	32	30	7	30	7	30	7	30	7	30	7	30	7	30	7
P03*	=	60	80	63	40	5.5	10	3.5	32	30	7	30	7	30	7	30	7	30	7	30	7	30	7
P04	=	70	90	75	60	6.5	10.5	3.5	32	30.5	7.5	30.5	7.5	30.5	7.5	30.5	7.5	30.5	7.5	30.5	7.5	30.5	7.5
P05	105	=	=	85	70	6.5	10.5	3.5	32	30.5	7.5	30.5	7.5	30.5	7.5	30.5	7.5	30.5	7.5	30.5	7.5	30.5	7.5
P06	=	80	110	98.42	73.02	6	11	3.5	35	31	8	31	8	31	8	31	8	31	8	31	8	31	8
P07	=	95	120	100	80	6.5	11.5	4	32	31.5	8.5	31.5	8.5	31.5	8.5	31.5	8.5	31.5	8.5	31.5	8.5	31.5	8.5
P08	=	98	130	115	95	9	11.5	4	32	31.5	8.5	31.5	8.5	31.5	8.5	31.5	8.5	31.5	8.5	31.5	8.5	31.5	8.5
P09	=	116	160	130	110	9	12	4.5	32	32	9	32	9	32	9	32	9	32	9	32	9	32	9
P10*	60	=	=	39	26	4.5	10	3	26	30	7	30	7	30	7	30	7	30	7	30	7	30	7
P11*	60	=	=	42	32	4.5	10	3	32	30	7	30	7	30	7	30	7	30	7	30	7	30	7
P12*	65	=	=	46	32	4.5	10	3.5	32	30	7	30	7	30	7	30	7	30	7	30	7	30	7
P13*	80	=	=	65	50	5.5	10	3.5	32	30	7	30	7	30	7	30	7	30	7	30	7	30	7
P14*	60	=	=	39	20	4.5	10	2.5	20	30	7	30	7	30	7	30	7	30	7	30	7	30	7
P15	=	75	100	90	60	5.8	12	3.5	32	32	9	32	9	32	9	32	9	32	9	32	9	32	9
P16*	60	=	=	45	30	3.5	14	7	30	34	11	34	11	34	11	34	11	34	11	34	11	34	11
P17	=	60	82	70	50	4.5	16.5	8	32	36.5	13.5	36.5	13.5	36.5	13.5	36.5	13.5	36.5	13.5	36.5	13.5	36.5	13.5
P18	=	60	80	60	50	M4	10.5	3.5	32	30.5	7.5	30.5	7.5	30.5	7.5	30.5	7.5	30.5	7.5	30.5	7.5	30.5	7.5
P19*	60	=	=	36	25	4.5	10	3	25	30	7	30	7	30	7	30	7	30	7	30	7	30	7
P20	=	60	82	70	50	5.5	10.5	3.5	32	30.5	7.5	30.5	7.5	30.5	7.5	30.5	7.5	30.5	7.5	30.5	7.5	30.5	7.5
P21*	60	=	=	46	30	4.5	10	3	30	30	7	30	7	30	7	30	7	30	7	30	7	30	7
P22	=	60	80	70.71	36	4.5	10	2	32	30	7	30	7	30	7	30	7	30	7	30	7	30	7
P23	=	62	85	70	50	5.5	15.5	3.5	32	35.5	12.5	35.5	12.5	35.5	12.5	35.5	12.5	35.5	12.5	35.5	12.5	35.5	12.5
P24	=	75	100	90	70	5.8	12	3.5	32	32	9	32	9	32	9	32	9	32	9	32	9	32	9
P25	=	70	95	85	55	5.8	12	3.5	32	32	9	32	9	32	9	32	9	32	9	32	9	32	9
P26*	=	60	80	65.5	34	5.5	10	3.5	33	30	7	30	7	30	7	30	7	30	7	30	7	30	7
P27	=	80	110	95	50	6.5	12	3.5	32	32	9	32	9	32	9	32	9	32	9	32	9	32	9
P28	=	60	80	66.67	38.1	M4	9	2.5	32	29	6	29	6	29	6	29	6	29	6	29	6	29	6
P29	60	=	=	45	30	M3	11	4	32	31	8	31	8	31	8	31	8	31	8	31	8	31	8
P30	=	70	95	85	60	5.8	12	3.5	32	32	9	32	9	32	9	32	9	32	9	32	9	32	9
P31	=	62	85	70	50	M4	11	3.5	32	31	8	31	8	31	8	31	8	31	8	31	8	31	8
P32	=	60	80	65	40	M5	10	3.5	32	30	7	30	7	30	7	30	7	30	7	30	7	30	7
P33	=	85	115	99	60	5.5	11	3.5	35	31	8	31	8	31	8	31	8	31	8	31	8	31	8
P34	=	65	87	73.54	40	M4	10	3.5	32	30	7	30	7	30	7	30	7	30	7	30	7	30	7
P35	=	60	80	70.71	36	M4	14	2	32	34	11	34	11	34	11	34	11	34	11	34	11	34	11
P36	=	85	115	98.42	73.02	6	15	3.5	35	35	12	35	12	35	12	35	12	35	12	35	12	35	12
P37	=	95	120	100	80	6.5	16.5	5	32														
P38	60	=	=	48	30	M3	11	7	32	31	8	31	8	31	8	31	8	31	8	31	8	31	8
P41*	68	=	=	50	30	5.5	10	10	30	30	7	30	7	30	7	30	7	30	7	30	7	30	7
P43	=	60	80	66.67	50	M5	9	2.5	32	29	6	29	6	29	6	29	6	29	6	29	6	29	6
P44*	60	=	=	32	25	4.5	9	2.5	20	29	6	29	6	29	6	29	6	29	6	29	6	29	6
P45	=	62	85	73.54	50	M5	10	3	32	30	7	30	7	30	7	30	7	30	7	30	7	30	7
P46	70	=	=	55	45	4.5	9	3	32	29	6	29	6	29	6	29	6	29	6	29	6	29	6
P47	=	90	118	104	83	6.5	14	3.5	32	34	11	34	11	34	11	34	11	34	11	34	11	34	11
P48*	60	=	=	38.88	25	4.5	10	3	25	30	7	30	7	30	7	30	7	30	7	30	7	30	7
P49	=	70	90	75	60	M5	10.5	3.5	32	30.5	7.5	30.5	7.5	30.5	7.5	30.5	7.5	30.5	7.5	30.5	7.5	30.5	7.5

* Per assemblare il motore è necessario smontare la flangia dal riduttore (vedere schema di montaggio 2 a pag. 47).

* Before the mounting of the motor it is necessary to remove the flange from the gearbox (see structural arrangement 2 at the top of the page 47).

* Vor dem Einbauen des Motors soll die Getriebeflang abmontiert werden (siehe Bauanleitung 2 auf Seite 47).

2.8 Dati tecnici

2.8 Technical data

2.8 Technische Daten

EP 75																		Stadi Steps Stufenzahl			
Stadi Steps Stufenzahl	1					2												1	2		
	i	3	4	5	7	10	9	12	15	16	20	25	28	35	40	50	70			100	
T _{2N}	22	28	32	28	20	26	32	36	36	36	36	36	36	36	36	30	22	n _{1nom}	4000		
T _{2A}	40	45	50	45	40	50	60	60	60	60	60	60	60	60	60	50	45	n _{1max}	5000		
T _{2S}	80	90	100	90	80	100	120	120	120	120	120	120	120	120	120	100	90	LpA	< 70		
J	Vedi pag. 31 / See page 31 / Siehe auf Seite 31																	Lh	20000		
R _t	3.5					3.0		3.5										3.0		F _{R2}	1800
R _d	0.96					0.93												F _{A2}	1400		
Kg	1.4					2.0												α _{max}	8' 10'		

F_{R2} Carico radiale nominale in uscita [N] a 100min⁻¹
 F_{A2} Carico assiale in uscita [N] a 100min⁻¹

Rated output radial load [N] at 100min⁻¹
 Output axial load [N] at 100min⁻¹

Nenn-Radiallast an der Abtriebswelle bei 100min⁻¹
 Axiallast an der Abtriebswelle bei 100min⁻¹

2.9 Dimensioni

2.9 Dimensions

2.9 Abmessungen

Dimensioni generali e uscite / General and output dimensions / General-und Abtriebsabmessungen

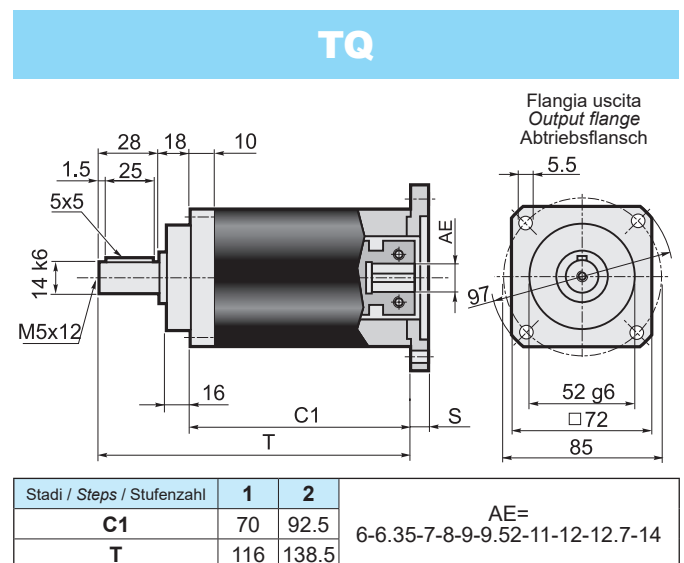
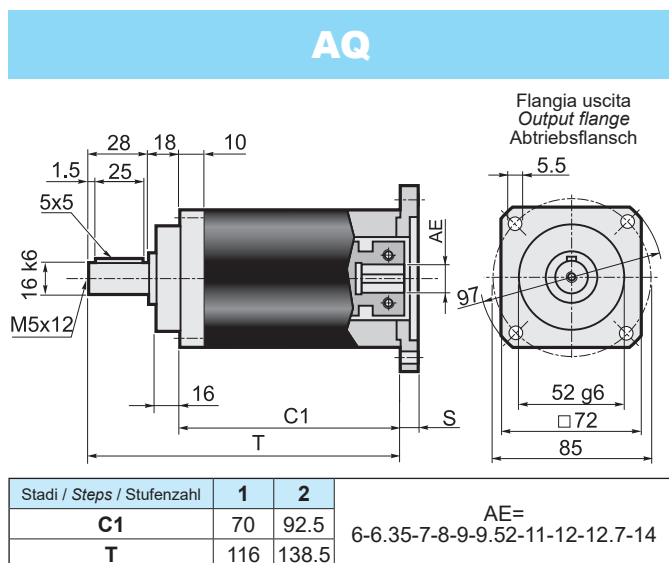
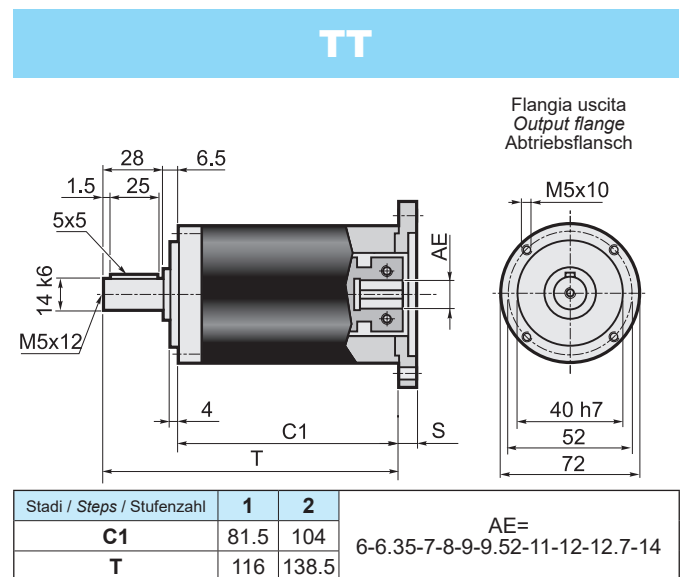
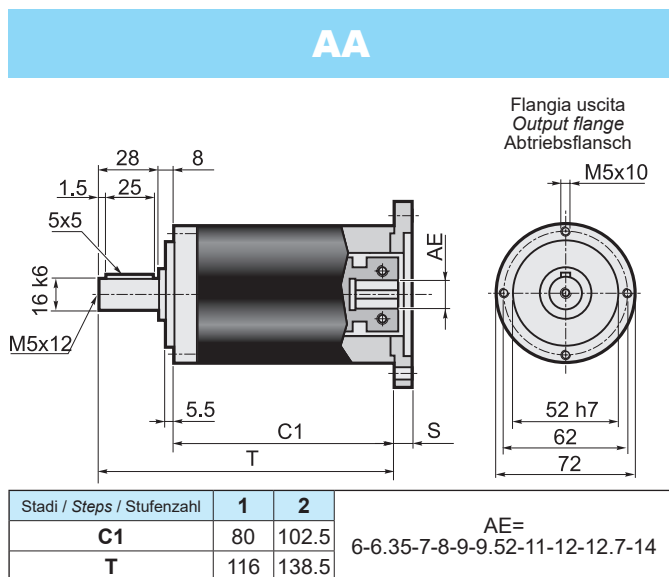

Dimensioni entrate / Input dimensions / Antriebsabmessungen

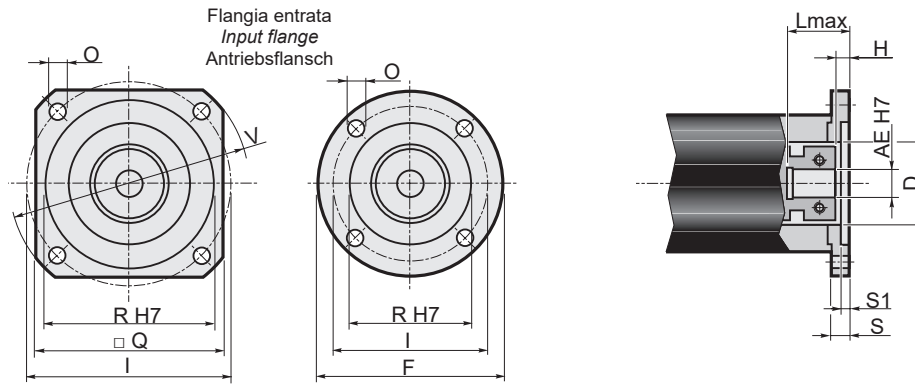

Flange entrata / Input flange / Antriebsflansch										Albero entrata / Input shaft / Antriebswelle																			
										AE																			
F	Q	V	I	R (H7)	O	S	S1	D	6		6.35		7		8		9		9.52		11		12		12.7		14		
									L max	H	L max	H	L max	H	L max	H	L max	H	L max	H	L max	H	L max	H	L max	H	L max	H	L max
P01*	60	=	=	43.82	22	4.5	10	3	22	35	4.5	35	4.5	35	4.5	26	6.5	26	6.5	35	6.5	26	6.5	35	6.5	35	6.5	35	6.5
P02*	=	60	80	66.67	38.1	5.5	10	3	32	35	4.5	35	4.5	35	4.5	26	6.5	26	6.5	35	6.5	26	6.5	35	6.5	35	6.5	35	6.5
P03*	=	60	80	63	40	5.5	10	3.5	32	35	4.5	35	4.5	35	4.5	26	6.5	26	6.5	35	6.5	26	6.5	35	6.5	35	6.5	35	6.5
P04	=	70	90	75	60	6.5	10.5	3.5	32	35.5	5	35.5	5	35.5	5	26.5	7	26.5	7	35.5	7	26.5	7	35.5	7	35.5	7	35.5	7
P05	105	=	=	85	70	6.5	10.5	3.5	32	35.5	5	35.5	5	35.5	5	26.5	7	26.5	7	35.5	7	26.5	7	35.5	7	35.5	7	35.5	7
P06	=	80	110	98.42	73.02	6	11	3.5	35	36	5.5	36	5.5	36	5.5	27	7.5	27	7.5	36	7.5	27	7.5	36	7.5	36	7.5	36	7.5
P07	=	95	120	100	80	6.5	11.5	4	32	36.5	6	36.5	6	36.5	6	27.5	8	27.5	8	36.5	8	27.5	8	36.5	8	36.5	8	36.5	8
P08	=	98	130	115	95	9	11.5	4	32	36.5	6	36.5	6	36.5	6	27.5	8	27.5	8	36.5	8	27.5	8	36.5	8	36.5	8	36.5	8
P09	=	116	160	130	110	9	12	4.5	32	37	6.5	37	6.5	37	6.5	28	8.5	28	8.5	37	8.5	28	8.5	37	8.5	37	8.5	37	8.5
P10*	60	=	=	39	26	4.5	10	3	26	35	4.5	35	4.5	35	4.5	26	6.5	26	6.5	35	6.5	26	6.5	35	6.5	35	6.5	35	6.5
P11*	60	=	=	42	32	4.5	10	3	32	35	4.5	35	4.5	35	4.5	26	6.5	26	6.5	35	6.5	26	6.5	35	6.5	35	6.5	35	6.5
P12*	65	=	=	46	32	4.5	10	3.5	32	35	4.5	35	4.5	35	4.5	26	6.5	26	6.5	35	6.5	26	6.5	35	6.5	35	6.5	35	6.5
P13*	80	=	=	65	50	5.5	10	3.5	32	35	4.5	35	4.5	35	4.5	26	6.5	26	6.5	35	6.5	26	6.5	35	6.5	35	6.5	35	6.5
P14*	60	=	=	39	20	4.5	10	2.5	20	35	4.5	35	4.5	35	4.5	26	6.5	26	6.5	35	6.5	26	6.5	35	6.5	35	6.5	35	6.5
P15	=	75	100	90	60	5.8	12	3.5	32	37	6.5	37	6.5	37	6.5	28	8.5	28	8.5	37	8.5	28	8.5	37	8.5	37	8.5	37	8.5
P16*	60	=	=	45	30	3.5	14	7	30	39	8.5	39	8.5	39	8.5	30	10.5	30	10.5	39	10.5	30	10.5	39	10.5	39	10.5	39	10.5
P17	=	60	82	70	50	4.5	16.5	8	32	41.5	11	41.5	11	41.5	11	32.5	13	32.5	13	41.5	13	32.5	13	41.5	13	41.5	13	41.5	13
P18	=	60	80	60	50	M4	10.5	3.5	32	35.5	5	35.5	5	35.5	5	26.5	7	26.5	7	35.5	7	26.5	7	35.5	7	35.5	7	35.5	7
P19*	60	=	=	36	25	4.5	10	3	25	35	4.5	35	4.5	35	4.5	26	6.5	26	6.5	35	6.5	26	6.5	35	6.5	35	6.5	35	6.5
P20	=	60	82	70	50	5.5	10.5	3.5	32	35.5	5	35.5	5	35.5	5	26.5	7	26.5	7	35.5	7	26.5	7	35.5	7	35.5	7	35.5	7
P21*	60	=	=	46	30	4.5	10	3	30	35	4.5	35	4.5	35	4.5	26	6.5	26	6.5	35	6.5	26	6.5	35	6.5	35	6.5	35	6.5
P22	=	60	80	70.71	36	4.5	10	2	32	35	4.5	35	4.5	35	4.5	26	6.5	26	6.5	35	6.5	26	6.5	35	6.5	35	6.5	35	6.5
P23	=	62	85	70	50	5.5	15.5	3.5	32	40.5	10	40.5	10	40.5	10	31.5	12	31.5	12	40.5	12	31.5	12	40.5	12	40.5	12	40.5	12
P24	=	75	100	90	70	5.8	12	3.5	32	37	6.5	37	6.5	37	6.5	28	8.5	28	8.5	37	8.5	28	8.5	37	8.5	37	8.5	37	8.5
P25	=	70	95	85	55	5.8	12	3.5	32	37	6.5	37	6.5	37	6.5	28	8.5	28	8.5	37	8.5	28	8.5	37	8.5	37	8.5	37	8.5
P26*	=	60	80	65.5	34	5.5	10	3.5	33	35	4.5	35	4.5	35	4.5	26	6.5	26	6.5	35	6.5	26	6.5	35	6.5	35	6.5	35	6.5
P27	=	80	110	95	50	6.5	12	3.5	32	37	6.5	37	6.5	37	6.5	28	8.5	28	8.5	37	8.5	28	8.5	37	8.5	37	8.5	37	8.5
P28	=	60	80	66.67	38.1	M4	9	2.5	32	34	3.5	34	3.5	34	3.5	25	5.5	25	5.5	34	5.5	25	5.5	34	5.5	34	5.5	34	5.5
P29	60	=	=	45	30	M3	11	4	32	36	5.5	36	5.5	36	5.5	27	7.5	27	7.5	36	7.5	27	7.5	36	7.5	36	7.5	36	7.5
P30	=	70	95	85	60	5.8	12	3.5	32	37	6.5	37	6.5	37	6.5	28	8.5	28	8.5	37	8.5	28	8.5	37	8.5	37	8.5	37	8.5
P31	=	62	85	70	50	M4	11	3.5	32	36	5.5	36	5.5	36	5.5	27	7.5	27	7.5	36	7.5	27	7.5	36	7.5	36	7.5	36	7.5
P32	=	60	80	65	40	M5	10	3.5	32	35	4.5	35	4.5	35	4.5	26	6.5	26	6.5	35	6.5	26	6.5	35	6.5	35	6.5	35	6.5
P33	=	85	115	99	60	5.5	11	3.5	32	36	5.5	36	5.5	36	5.5	27	7.5	27	7.5	36	7.5	27	7.5	36	7.5	36	7.5	36	7.5
P34	=	65	87	73.54	40	M4	10	3.5	32	35	4.5	35	4.5	35	4.5	26	6.5	26	6.5	35	6.5	26	6.5	35	6.5	35	6.5	35	6.5
P35	=	60	80	70.71	36	M4	14	2	32	39	8.5	39	8.5	39	8.5	30	10.5	30	10.5	39	10.5	30	10.5	39	10.5	39	10.5	39	10.5
P36	=	85	115	98.42	73.02	6	15	3.5	35	40	9.5	40	9.5	40	9.5	35	11.5	31	11.5	40	11.5	35	11.5	40	11.5	40	11.5	40	11.5
P37	=	95	120	100	80	6.5	16.5	5	32	41.5	11	41.5	11	41.5	11	32.5	13	32.5	13	41.5	13	32.5	13	41.5	13	41.5	13	41.5	13
P38	60	=	=	48	30	M3	11	7	32	36	5.5	36	5.5	36	5.5	27	7.5	27	7.5	36	7.5	27	7.5	36	7.5	36	7.5	36	7.5
P41*	68	=	=	50	30	5.5	10	10	30	35	4.5	35	4.5	35	4.5	26	6.5	26	6.5	35	6.5	26	6.5	35	6.5	35	6.5	35	6.5
P43	=	60	80	66.67	50	M5	9	2.5	32	34	3.5	34	3.5	34	3.5	25	5.5	25	5.5	34	5.5	25	5.5	34	5.5	34	5.5	34	5.5
P44*	60	=	=	32	25	4.5	9	2.5	20	34	3.5	34	3.5	34	3.5	25	5.5	25	5.5	34	5.5	25	5.5	34	5.5	34	5.5	34	5.5
P45	=	62	85	73.54	50	M5	10	3	32	35	4.5	35	4.5	35	4.5	26	6.5	26	6.5	35	6.5	26	6.5	35	6.5	35	6.5	35	6.5
P46	70	=	=	55	45	4.5	9	3	32	34	3.5	34	3.5	34	3.5	25	5.5	25	5.5	34	5.5	25	5.5	34	5.5	34	5.5	34	5.5
P47	=	90	118	104	83	6.5	14	3.5	32	39	8.5	39	8.5	39	8.5	30	10.5	30	10.5	39	10.5	30	10.5	39	10.5	39	10.5	39	10.5
P48	60	=	=	38.88	25	4.5	10	3	25	35	4.5	35	4.5	35	4.5	26	6.5	26	6.5	35	6.5	26	6.5	35	6.5	35	6.5	35	6.5
P49	=	70	90	75	60	M5	10.5	3.5	32	35.5	5	35.5	5	35.5	5	26.5	7	26.5	7	35.5	7	26.5	7	35.5	7	35.5	7	35.5	7

* Per assemblare il motore è necessario smontare la flangia dal riduttore (vedere schema di montaggio 2 a pag. 47).

* Before the mounting of the motor it is necessary to remove the flange from the gearbox (see structural arrangement 2 at the top of the page 47).

* Vor dem Einbauen des Motors soll die Getriebeflang abmontiert werden (siehe Bauanleitung 2 auf Seite 47).

EP 90																		Stadi Steps Stufenzahl		
Stadi Steps Stufenzahl	1					2												1	2	
	i	3	4	5	7	10	9	12	15	16	20	25	28	35	40	50	70			100
T_{2N}	50	55	60	55	50	65	70	75	75	75	75	75	75	75	75	65	55	n_{1nom}	4000	
T_{2A}	80	90	100	90	80	100	110	120	120	120	120	120	120	120	120	100	90	n_{1max}	5000	
T_{2S}	160	180	200	180	160	200	220	240	240	240	240	240	240	240	240	200	180	LpA	< 70	
J	Vedi pag. 32 / See page 32 / Siehe auf Seite 32																	Lh	20000	
R_t	9.0					7.5					9.0					7.5			F_{R2}	2600
R_d	0.96					0.93												F_{A2}	2000	
Kg	2.8					3.7												α_{max}	8' 10'	

F_{R2} Carico radiale nominale in uscita [N] a 100min⁻¹
F_{A2} Carico assiale in uscita [N] a 100min⁻¹

Rated output radial load [N] at 100min⁻¹
 Output axial load [N] at 100min⁻¹

Nenn-Radiallast an der Abtriebswelle bei 100min⁻¹
 Axiallast an der Abtriebswelle bei 100min⁻¹

2.9 Dimensioni

2.9 Dimensions

2.9 Abmessungen

Dimensioni generali e uscite / General and output dimensions / General-und Abtriebsabmessungen

AA

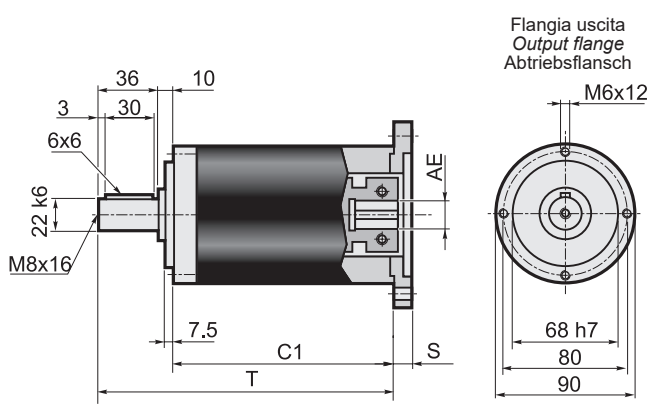

Flangia uscita
Output flange
Abtriebsflansch

Stadi / Steps / Stufenzahl	1	2	AE=
C1	98	127	
T	144	173	

TT

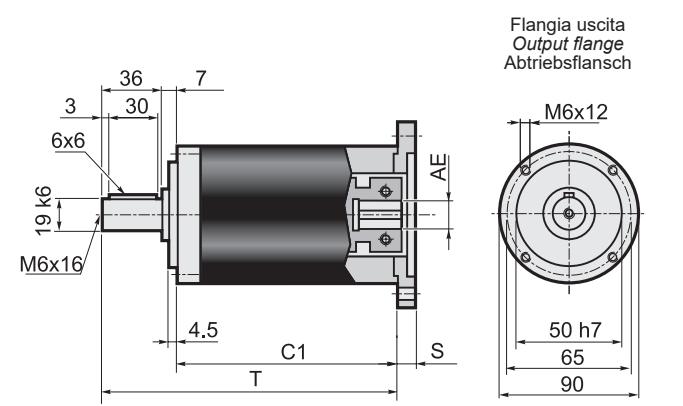

Flangia uscita
Output flange
Abtriebsflansch

Stadi / Steps / Stufenzahl	1	2	AE=
C1	101	130	
T	144	173	

AQ

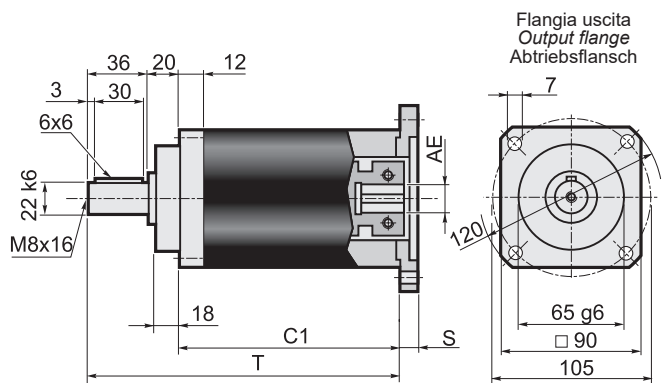

Flangia uscita
Output flange
Abtriebsflansch

Stadi / Steps / Stufenzahl	1	2	AE=
C1	88	117	
T	144	173	

TQ

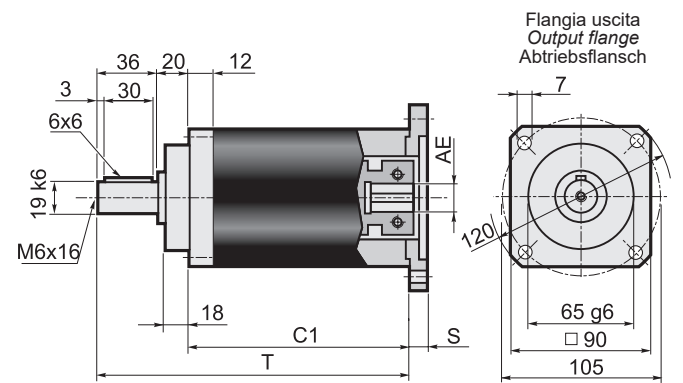

Flangia uscita
Output flange
Abtriebsflansch

Stadi / Steps / Stufenzahl	1	2	AE=
C1	88	117	
T	144	173	

Dimensioni entrate / Input dimensions / Antriebsabmessungen

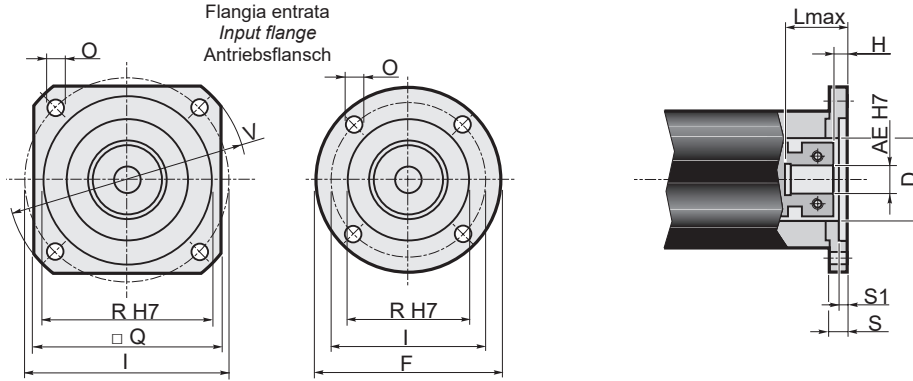

Flange entrata / Input flange / Antriebsflansch										Albero entrata / Input shaft / Antriebswelle																	
										AE																	
F	Q	V	I	R (H7)	O	S	S1	D	9		9.525		11		12		12.7		14		15.87		16		19		
									L _{max}	H	L _{max}	H	L _{max}	H	L _{max}	H	L _{max}	H	L _{max}	H	L _{max}	H	L _{max}	H	L _{max}	H	
P01*	80	=	=	66.67	38.1	5.5	12	3	38.1	44	6.5	44	9	44	9	44	9	44	9	44	9	44	9	44	9	44	9
P02	=	106.5	140	125.72	55.52	7	11	3	45	43	5.5	43	8	43	8	43	8	43	8	43	8	43	8	43	8	43	8
P03*	=	80	90	75	60	5.5	12	3.5	45	44	6.5	44	9	44	9	44	9	44	9	44	9	44	9	44	9	44	9
P04*	105	=	=	85	70	6.5	12	3.5	45	44	6.5	44	9	44	9	44	9	44	9	44	9	44	9	44	9	44	9
P05	=	82.5	110	98.425	73.02	6.5	12	3	45	44	6.5	44	9	44	9	44	9	44	9	44	9	44	9	44	9	44	9
P06	=	90	120	100	80	6.5	13	4	45	45	7.5	45	10	45	10	45	10	45	10	45	10	45	10	45	10	45	10
P07	=	100	135	115	95	8.5	13	4.5	45	45	7.5	45	10	45	10	45	10	45	10	45	10	45	10	45	10	45	10
P08	=	116	160	130	110	9	13	4.5	45	45	7.5	45	10	45	10	45	10	45	10	45	10	45	10	45	10	45	10
P09*	80	=	=	39	26	4.5	12	4	26	44	6.5	44	9	44	9	44	9	44	9	44	9	44	9	44	9	44	9
P10*	80	=	=	65	50	5.5	12	3.5	45	44	6.5	44	9	44	9	44	9	44	9	44	9	44	9	44	9	44	9
P11	=	150	182	166	115	9	32	11	50x14	64	26.5	64	29	64	29	64	29	64	29	64	29	64	29	64	29	64	29
P12*	=	80	105	90	70	6.5	12	3.5	32	44	6.5	44	9	44	9	44	9	44	9	44	9	44	9	44	9	44	9
P14*	105	=	=	90	70	6	19	9	32	51	13.5	51	16	51	16	51	16	51	16	51	16	51	16	51	16	51	16
P15*	80	=	=	70	50	4.5	17	8	45	49	11.5	49	14	49	14	49	14	49	14	49	14	49	14	49	14	49	14
P16	=	142	190	165	130	11	13	4.5	45	45	7.5	45	10	45	10	45	10	45	10	45	10	45	10	45	10	45	10
P17*	80	=	=	63	40	5.5	12	3.5	40	44	6.5	44	9	44	9	44	9	44	9	44	9	44	9	44	9	44	9
P18	=	130	170	145	110	M8	31	7	32	63	25.5	63	28	63	28	63	28	63	28	63	28	63	28	63	28	63	28
P19*	=	80	105	90	60	6.5	12	3.5	32	44	6.5	44	9	44	9	44	9	44	9	44	9	44	9	44	9	44	9
P20*	=	80	105	85	55	5.5	12	3.5	36	44	6.5	44	9	44	9	44	9	44	9	44	9	44	9	44	9	44	9
P21	=	80	110	95	50	M6	12	3.5	45	44	6.5	44	9	44	9	44	9	44	9	44	9	44	9	44	9	44	9
P22	80	=	=	70	50	M4	12	4	45	44	6.5	44	9	44	9	44	9	44	9	44	9	44	9	44	9	44	9
P23	=	80	90	75	60	M5	12	3.5	45	44	6.5	44	9	44	9	44	9	44	9	44	9	44	9	44	9	44	9
P24	80	=	=	46	30	M4	12	4	30	44	6.5	44	9	44	9	44	9	44	9	44	9	44	9	44	9	44	9
P26	80	=	=	65	40	M5	12	3.5	40	44	6.5	44	9	44	9	44	9	44	9	44	9	44	9	44	9	44	9
P27	=	80	110	82.02	36.8	M6	14	10	36.8	46	8.5	46	11	46	11	46	11	46	11	46	11	46	11	46	11	46	11
P28	=	90	120	100	80	6.5	28	4	45	60	22.5	60	25	60	25	60	25	60	25	60	25	60	25	60	25	60	25
P29*	80	=	=	66.67	50	5.5	12	3	45	44	6.5	44	9	44	9	44	9	44	9	44	9	44	9	44	9	44	9
P30	=	115	155	130	80	9	13	4	45	45	7.5	45	10	45	10	45	10	45	10	45	10	45	10	45	10	45	10
P31*	=	80	105	56	44	M6	14	10	36.8	46	8.5	46	11	46	11	46	11	46	11	46	11	46	11	46	11	46	11
P32	=	80	105	90	70	M6	12	3.5	32	44	6.5	44	9	44	9	44	9	44	9	44	9	44	9	44	9	44	9
P33	=	130	165	145	110	9	13	4.5	45	45	7.5	45	10	45	10	45	10	45	10	45	10	45	10	45	10	45	10
P34	=	90	120	100	80	M6	19	5	45	51	13.5	51	16	51	16	51	16	51	16	51	16	51	16	51	16	51	16
P36	=	100	135	115	95	M8	25	4.5	45	57	19.5	57	22	57	22	57	22	57	22	57	22	57	22	57	22	57	22
P37	=	85	115	98.99	60	M6	12	3.5	32	44	6.5	44	9	44	9	44	9	44	9	44	9	44	9	44	9	44	9
P38	80	=	=	70	50	M5	12	4	45	44	6.5	44	9	44	9	44	9	44	9	44	9	44	9	44	9	44	9
P39	=	90	120	100	80	6.5	13	4.5	45	45	7.5	45	10	45	10	45	10	45	10	45	10	45	10	45	10	45	10
P40	=	80	90	75	60	M6	12	3.5	45	44	6.5	44	9	44	9	44	9	44	9	44	9	44	9	44	9	44	9
P42	=	110	145	125.72	55.5	M8	28	3	45	60	22.5	60	25	60	25	60	25	60	25	60	25	60	25	60	25	60	25
P44*	=	80	105	90	70	6	13	5	32	45	7.5	45	10	45	10	45	10	45	10	45	10	45	10	45	10	45	10
P46	=	100	135	115	95	8.5	17	8	45	49	11.5	49	14	49	14	49	14	49	14	49	14	49	14	49	14	49	14
P47	=	90	120	100	50	M6	12	4.5	45	44	6.5	44	9	44	9	44	9	44	9	44	9	44	9	44	9	44	9

* Per assemblare il motore è necessario smontare la flangia dal riduttore (vedere schema di montaggio 2 a pag. 47).

* Before the mounting of the motor it is necessary to remove the flange from the gearbox (see structural arrangement 2 at the top of the page 47).

* Vor dem Einbauen des Motors soll die Getriebeflang abmontiert werden (siehe Bauanleitung 2 auf Seite 47).

EP 120																			Stadi Steps Stufenzahl	
Stadi Steps Stufenzahl	1					2								1	2					
	i	3	4	5	7	10	9	12	15	16	20	25	28			35	40	50	70	100
T _{2N}	120	150	180	150	100	150	180	220	220	220	220	220	220	220	220	170	110	n _{1nom}	3000	
T _{2A}	190	240	290	220	180	240	290	350	350	350	350	350	350	350	350	270	200	n _{1max}	4000	
T _{2S}	400	500	600	460	380	500	600	700	700	700	700	700	700	700	700	540	400	LpA	< 70	
J	Vedi pag. 32 / See page 32 / Siehe auf Seite 32																	Lh	20000	
R _t	32					28	32	30					28					F _{R2}	4500	
R _d	0.96					0.93												F _{A2}	4000	
Kg	7.5					8.0												α _{max}	8' 10'	

F_{R2} Carico radiale nominale in uscita [N] a 100min⁻¹
 F_{A2} Carico assiale in uscita [N] a 100min⁻¹

Rated output radial load [N] at 100min⁻¹
 Output axial load [N] at 100min⁻¹

Nenn-Radiallast an der Abtriebswelle bei 100min⁻¹
 Axiallast an der Abtriebswelle bei 100min⁻¹

2.9 Dimensioni

2.9 Dimensions

2.9 Abmessungen

Dimensioni generali e uscite / General and output dimensions / General-und Abtriebsabmessungen

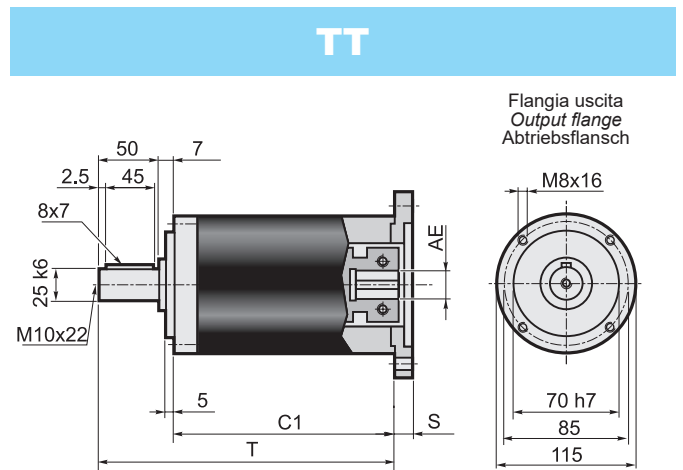
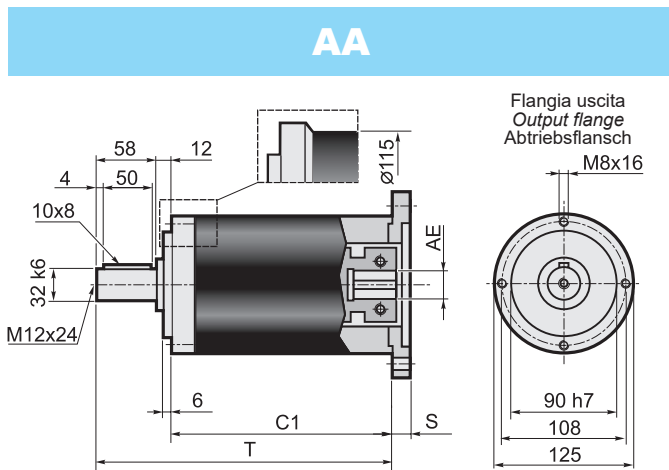

Stadi / Steps / Stufenzahl	1	2	AE=
C1	115.8	148.4	
T	185.8	218.4	
Stadi / Steps / Stufenzahl	1	2	AE=
C1	134.8	167.4	
T	185.8	218.4	

Stadi / Steps / Stufenzahl	1	2	AE=
C1	120.8	153.4	
T	177.8	210.4	
Stadi / Steps / Stufenzahl	1	2	AE=
C1	139.8	172.4	
T	196.8	229.4	

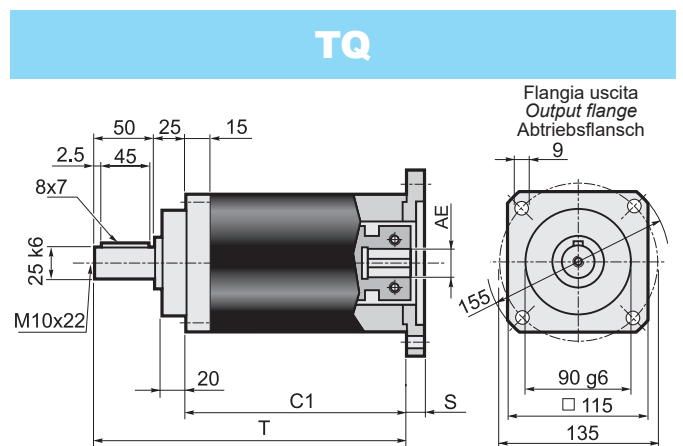
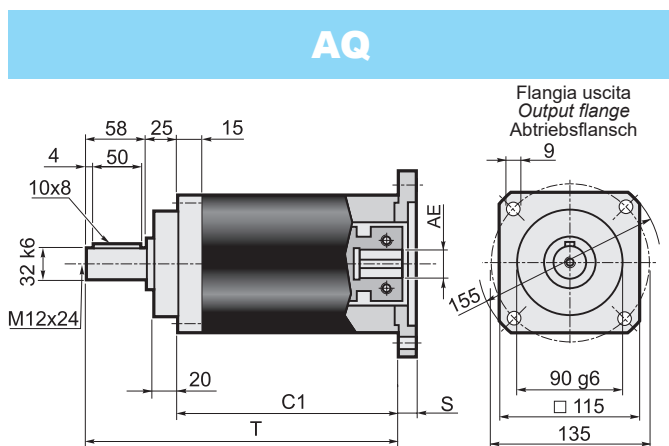

Stadi / Steps / Stufenzahl	1	2	AE=
C1	102.8	135.4	
T	185.8	218.4	
Stadi / Steps / Stufenzahl	1	2	AE=
C1	121.8	154.4	
T	204.8	237.4	

Stadi / Steps / Stufenzahl	1	2	AE=
C1	102.8	135.4	
T	177.8	210.4	
Stadi / Steps / Stufenzahl	1	2	AE=
C1	121.8	154.4	
T	196.8	229.4	

Dimensioni entrate / Input dimensions / Antriebsabmessungen

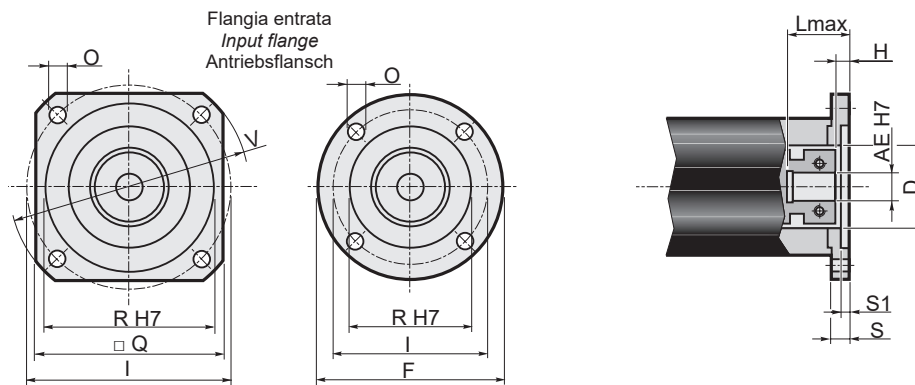

Flange entrata / Input flange / Antriebsflansch										Albero entrata / Input shaft / Antriebswelle																	
										AE																	
										12.7		14		15.87		16		19		22		24		25		28	
F	Q	V	I	R (H7)	O	S	S1	D	L _{max}	H	L _{max}	H	L _{max}	H	L _{max}	H	L _{max}	H	L _{max}	H	L _{max}	H	L _{max}	H			
P01*	=	115	140	125.72	55.52	6.5	13	3	55.52	43	6	43	6	43	6	43	6	43	6	62	6	62	6	62	6	62	6
P02*	115	=	=	75	60	5.5	13	3.5	60	43	6	43	6	43	6	43	6	43	6	62	6	62	6	62	6	62	6
P03*	115	=	=	85	70	6.5	13	3.5	60	43	6	43	6	43	6	43	6	43	6	62	6	62	6	62	6	62	6
P04*	115	=	=	98.42	73.02	6.5	13	3	60	43	6	43	6	43	6	43	6	43	6	62	6	62	6	62	6	62	6
P05*	120	=	=	100	80	6.5	13	4	60	43	6	43	6	43	6	43	6	43	6	62	6	62	6	62	6	62	6
P06*	=	115	140	115	95	9	13	4.5	60	43	6	43	6	43	6	43	6	43	6	62	6	62	6	62	6	62	6
P07	=	115	160	130	110	8.5	13	4.5	60	43	6	43	6	43	6	43	6	43	6	62	6	62	6	62	6	62	6
P08	=	142	190	165	130	11	13	4.5	60	43	6	43	6	43	6	43	6	43	6	62	6	62	6	62	6	62	6
P09	=	192	250	215	180	13	14	4.5	60	44	7	44	7	44	7	44	7	44	7	63	7	63	7	63	7	63	7
P10*	115	=	=	65	50	6.5	13	3.5	50	43	6	43	6	43	6	43	6	43	6	62	6	62	6	62	6	62	6
P11	=	130	170	145	110	M 8	31	7	60	61	24	61	24	61	24	61	24	61	24	80	24	80	24	80	24	80	24
P12	=	130	170	145	110	M 8	17	7	60	47	10	47	10	47	10	47	10	47	10	66	10	66	10	66	10	66	10
P13	=	115	160	130	110	M 8	13	4.5	60	43	6	43	6	43	6	43	6	43	6	62	6	62	6	62	6	62	6
P14*	115	=	=	70	50	6.5	13	3.5	50	43	6	43	6	43	6	43	6	43	6	62	6	62	6	62	6	62	6
P15	115	=	=	90	70	M5	11	3.5	60	41	4	41	4	41	4	41	4	41	4	60	4	60	4	60	4	60	4
P17*	115	=	=	90	70	6.5	13	3.5	60	43	6	43	6	43	6	43	6	43	6	62	6	62	6	62	6	62	6
P18	=	115	155	130	95	8.5	13	4.5	60	43	6	43	6	43	6	43	6	43	6	62	6	62	6	62	6	62	6
P19*	115	=	=	95	50	6.5	13	3.5	50	43	6	43	6	43	6	43	6	43	6	62	6	62	6	62	6	62	6
P20	115	=	=	99	60	M6	13	4	60	43	6	43	6	43	6	43	6	43	6	62	6	62	6	62	6	62	6
P21*	130	=	=	106	82.5	12.5	26.5	15	60	56.5	19.5	56.5	19.5	56.5	19.5	56.5	19.5	56.5	19.5	75.5	19.5	75.5	19.5	75.5	19.5	75.5	19.5
P22	=	144	190	165	110	11	15	4.5	60	45	8	45	8	45	8	45	8	45	8	64	8	64	8	64	8	64	8
P23*	115	=	=	63	40	5.5	11	3.5	40	41	4	41	4	41	4	41	4	41	4	60	4	60	4	60	4	60	4
P24	120	=	=	100	80	M6	18	7	60	48	11	48	11	48	11	48	11	48	11	67	11	67	11	67	11	67	11
P25	=	115	155	115	95	M8	27	4.5	60	57	20	57	20	57	20	57	20	57	20	76	20	76	20	76	20	76	20
P26	=	115	155	131.95	55.52	M8	27	4.5	60	57	20	57	20	57	20	57	20	57	20	76	20	76	20	76	20	76	20
P27	170	=	=	148	114	8.5	13	4	60	43	6	43	6	43	6	43	6	43	6	62	6	62	6	62	6	62	6
P28	=	115	140	115	95	M8	16	6	60	46	9	46	9	46	9	46	9	46	9	65	9	65	9	65	9	65	9
P29	133,5	=	=	121.5	60	M6	13	13	60	43	6	43	6	43	6	43	6	43	6	62	6	62	6	62	6	62	6

* Per assemblare il motore è necessario smontare la flangia dal riduttore (vedere schema di montaggio 2 a pag. 47).

* Before the mounting of the motor it is necessary to remove the flange from the gearbox (see structural arrangement 2 at the top of the page 47).

* Vor dem Einbauen des Motors soll die Getriebeflang abmontiert werden (siehe Bauanleitung 2 auf Seite 47).

2.8 Dati tecnici

2.8 Technical data

2.8 Technische Daten

EP 155																		Stadi Steps Stufenzahl	
Stadi Steps Stufenzahl	1					2												1	2
i	3	4	5	7	10	9	12	15	16	20	25	28	35	40	50	70	100	1	2
T _{2N}	240	320	380	300	220	320	400	500	500	500	500	500	500	500	500	350	250	n _{1nom}	3000
T _{2A}	420	540	600	480	400	480	600	750	750	750	750	750	750	750	750	560	460	n _{1max}	4000
T _{2S}	880	1140	1260	1000	850	1000	1250	1500	1500	1500	1500	1500	1500	1500	1500	1120	920	L _{pA}	< 70
J	Vedi pag. 33 / See page 33 / Siehe auf Seite 33																	L _h	20000
R _t	60				50	60											50	F _{R2} (AA) F _{R2} (TT)	6500 5300
R _d	0.96					0.93												F _{A2} (AA) F _{A2} (TT)	3250 2650
Kg	10.9					15.7												α _{max}	8' 10'

F_{R2} Carico radiale nominale in uscita [N] a 100min⁻¹
F_{A2} Carico assiale in uscita [N] a 100min⁻¹

Rated output radial load [N] at 100min⁻¹
Output axial load [N] at 100min⁻¹

Nenn-Radiallast an der Abtriebswelle bei 100min⁻¹
Axiallast an der Abtriebswelle bei 100min⁻¹

2.9 Dimensioni

2.9 Dimensions

2.9 Abmessungen

Dimensioni generali e uscite / General and output dimensions / General-und Abtriebsabmessungen

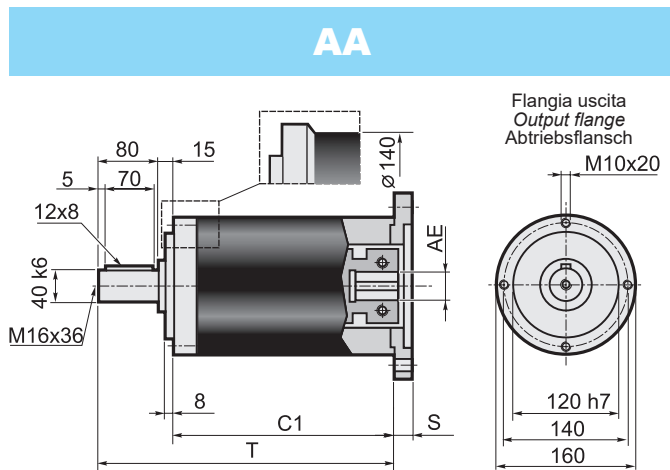

Stadi / Steps / Stufenzahl	1	2	AE= 15.87-16-19-22-24
C1	156	197.5	
T	251	292.5	
Stadi / Steps / Stufenzahl	1	2	AE= 28-32-35-38
C1	181	222.5	
T	276	317.5	

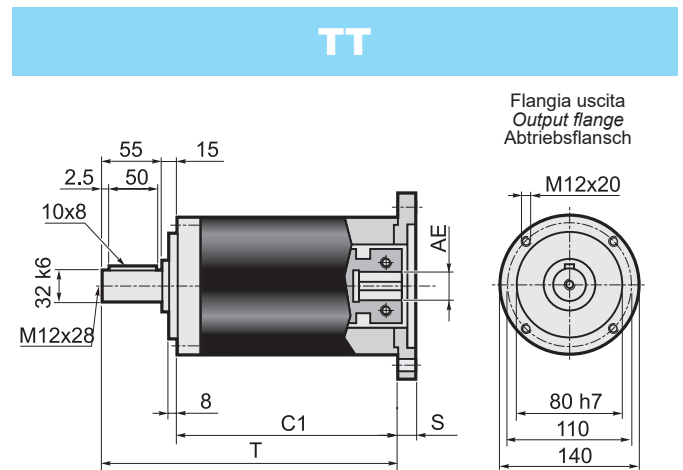

Stadi / Steps / Stufenzahl	1	2	AE= 15.87-16-19-22-24
C1	156	197.5	
T	226	267.5	
Stadi / Steps / Stufenzahl	1	2	AE= 28-32-35-38
C1	181	222.5	
T	251	292.5	

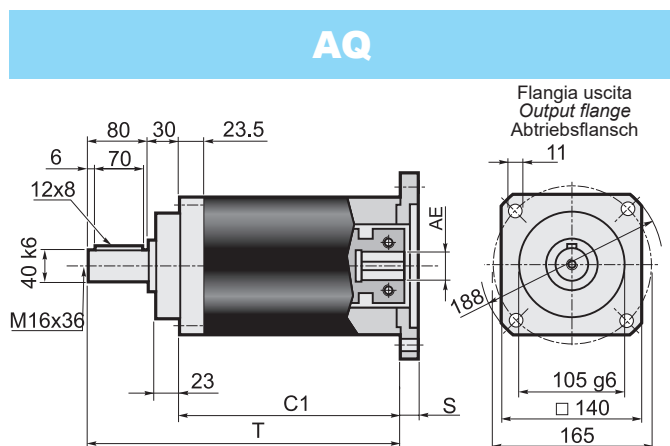

Stadi / Steps / Stufenzahl	1	2	AE= 15.87-16-19-22-24
C1	141	182.5	
T	251	292.5	
Stadi / Steps / Stufenzahl	1	2	AE= 28-32-35-38
C1	166	207.5	
T	276	317.5	

Dimensioni entrate / Input dimensions / Antriebsabmessungen

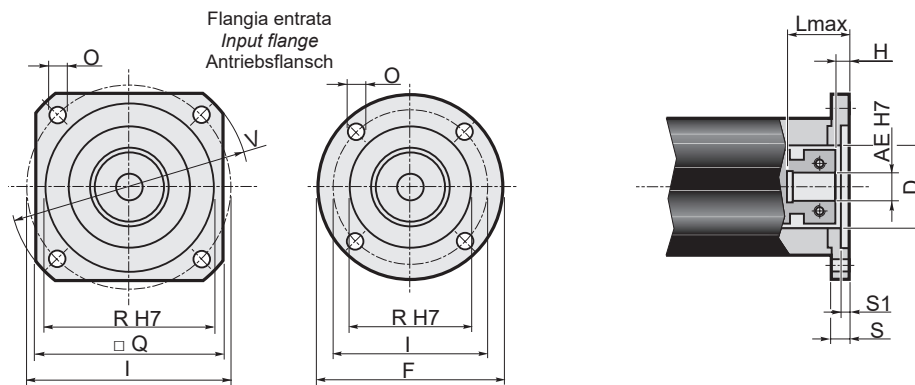

Flange entrata / Input flange / Antriebsflansch										Albero entrata / Input shaft / Antriebswelle															
										AE															
										15.87		16		19		22		24		28		32		35	
F	Q	V	I	R (H7)	O	S	S1	D	L _{max}	H	L _{max}	H	L _{max}	H	L _{max}	H	L _{max}	H	L _{max}	H	L _{max}	H			
P01*	140	=	=	125.72	55.52	6.5	15	4	55.52	57.8	6.8	57.8	6.8	57.8	6.8	57.8	6.8	57.8	6.8	82.8	7.3	82.8	7.3	82.8	7.3
P02*	140	=	=	100	80	6.5	15	4	70	57.8	6.8	57.8	6.8	57.8	6.8	57.8	6.8	57.8	6.8	82.8	7.3	82.8	7.3	82.8	7.3
P03*	140	=	=	115	95	8.5	15	4.5	70	57.8	6.8	57.8	6.8	57.8	6.8	57.8	6.8	57.8	6.8	82.8	7.3	82.8	7.3	82.8	7.3
P04*	=	140	160	130	110	8.5	15	4.5	70	57.8	6.8	57.8	6.8	57.8	6.8	57.8	6.8	57.8	6.8	82.8	7.3	82.8	7.3	82.8	7.3
P05	=	142	190	165	130	11	15	4.5	70	57.8	6.8	57.8	6.8	57.8	6.8	57.8	6.8	57.8	6.8	82.8	7.3	82.8	7.3	82.8	7.3
P06	=	190	250	215	180	13	15	4.5	70	57.8	6.8	57.8	6.8	57.8	6.8	57.8	6.8	57.8	6.8	82.8	7.3	82.8	7.3	82.8	7.3
P07	=	250	300	265	230	13	15	4.5	70	57.8	6.8	57.8	6.8	57.8	6.8	57.8	6.8	57.8	6.8	82.8	7.3	82.8	7.3	82.8	7.3
P08	=	130	165	145	110	M 8	18	7	70	60.8	9.8	60.8	9.8	60.8	9.8	60.8	9.8	60.8	9.8	85.8	10.3	85.8	10.3	85.8	10.3
P09	=	180	230	200	114.3	13.5	22	11	70	64.8	13.8	64.8	13.8	64.8	13.8	64.8	13.8	64.8	13.8	89.8	14.3	89.8	14.3	89.8	14.3
P10	=	115	150	130	95	M 8	15	4.5	70	57.8	6.8	57.8	6.8	57.8	6.8	57.8	6.8	57.8	6.8	82.8	7.3	82.8	7.3	82.8	7.3
P11	=	180	230	198	155	13.5	22	7	120x11	64.8	13.8	64.8	13.8	64.8	13.8	64.8	13.8	64.8	13.8	89.8	14.3	89.8	14.3	89.8	14.3
P12	=	220	270	235	200	13.5	15	5	70	57.8	6.8	57.8	6.8	57.8	6.8	57.8	6.8	57.8	6.8	82.8	7.3	82.8	7.3	82.8	7.3
P13	=	190	250	215	130	13	15	4.5	70	57.8	6.8	57.8	6.8	57.8	6.8	57.8	6.8	57.8	6.8	82.8	7.3	82.8	7.3	82.8	7.3
P14	=	142	190	165	110	11	15	4.5	70	57.8	6.8	57.8	6.8	57.8	6.8	57.8	6.8	57.8	6.8	82.8	7.3	82.8	7.3	82.8	7.3
P15*	150	=	=	90	70	6.5	15	4	70	57.8	6.8	57.8	6.8	57.8	6.8	57.8	6.8	57.8	6.8	82.8	7.3	82.8	7.3	82.8	7.3
P16	=	146	200	177.8	114.3	10.5	15	3.5	70	57.8	6.8	57.8	6.8	57.8	6.8	57.8	6.8	57.8	6.8	82.8	7.3	82.8	7.3	82.8	7.3
P17	=	130	165	145	110	M 8	28	7	70	70.8	19.8	70.8	19.8	70.8	19.8	70.8	19.8	70.8	19.8	95.8	20.3	95.8	20.3	95.8	20.3
P18	140	=	=	100	80	M 6	22	6	70	64.8	13.8	64.8	13.8	64.8	13.8	64.8	13.8	64.8	13.8	89.8	14.3	89.8	14.3	89.8	14.3
P19	=	130	165	145	110	M 8	27	7	70	69.8	18.8	69.8	18.8	69.8	18.8	69.8	18.8	69.8	18.8	94.8	19.3	94.8	19.3	94.8	19.3

* Per assemblare il motore è necessario smontare la flangia dal riduttore (vedere schema di montaggio 2 a pag. 47).

* Before the mounting of the motor it is necessary to remove the flange from the gearbox (see structural arrangement 2 at the top of the page 47).

* Vor dem Einbauen des Motors soll die Getriebeflang abmontiert werden (siehe Bauanleitung 2 auf Seite 47).

1 Schema di montaggio / Assembly drawing / Bauanleitung 1

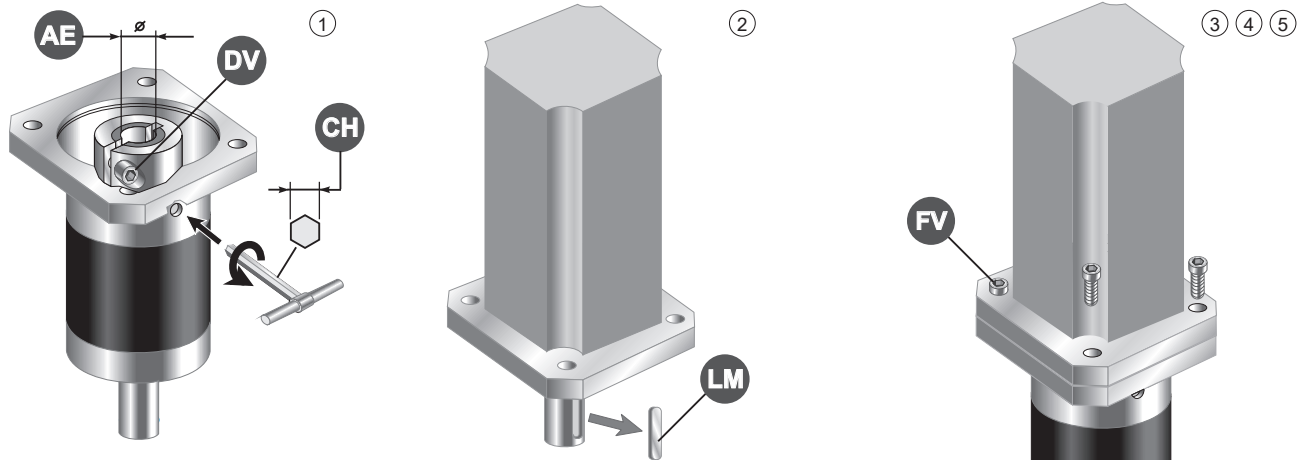

- 1 - Allentare la vite di serraggio del morsetto (DV)
- 2 - Estrarre la linguetta (LM) dall'albero motore
- 3 - Pulire le superfici di contatto delle flange motore e riduttore
- 4 - Calettare il motore sul riduttore evitando urti
- 5 - Stringere le viti di assemblaggio (FV) in modo alternato
- 6 - Assicurarsi che il morsetto venga serrato posizionandolo verso il motore e rispettando la fasatura dei tagli
- 7 - Serrare la vite (o le viti) del morsetto (DV) alla coppia (CS) indicata in tabella

- 1 - Unloose the fastening screw (or screws) of the clamp (DV)
- 2 - Remove the key (LM) from motor shaft
- 3 - Clean the contact surfaces of motor flange/gearbox flange
- 4 - Avoid impacts while fitting motor to gearbox
- 5 - Tighten the assembling screws (FV) alternately
- 6 - Fix the clamp towards the motor and tighten it in compliance with the cuts timing
- 7 - Tighten the clamp screw, or screws (DV) according to the torque (CS) reported in the table

- 1 - die Befestigungsschraube der Klammer (DV) lockern
- 2 - die Feder (LM) aus Motorwelle ziehen
- 3 - die Motorflansch / Getriebeflansch Kontaktfläche reinigen
- 4 - Motor und Getriebe ohne Stöße verkeilen
- 5 - die Befestigungsschrauben (FV) abwechselnd anziehen
- 6 - Die Klammer soll zum Motor angezogen. Dabei soll die Zuendeinstellung de Schnitte geachtet
- 7 - die Schraube (oder Schrauben) der Klammer (DV) zu dem in der Tabelle angegebenen Anzugsmoment anziehen

EP 55	AE	6	6.35	7	8	9	9.52	11				
	DV	M4 x 16										
	NV	1										
	CH	3										
	CS [Nm]	4.8										
EP 75	AE	6	6.35	7	8	9	9.52	11	12	12.7	14	
	DV	M4 x 16										
	NV	1										
	CH	3										
	CS [Nm]	4.8										
EP 90	AE	9	9.52	11	12	12.7	14	15.87	16	19		
	DV	M4 x 16						M5 x 20				
	NV	1						1				
	CH	3						4				
	CS [Nm]	4.8						9.4				
EP 120	AE	12.7	14	15.87	16	19	22	24	25	28		
	DV	M4 x 16		M5 x 20			M6 x 20					
	NV	1		1			2					
	CH	3		4			5					
	CS [Nm]	4.8		9.4			16.2					
EP 155	AE	15.87	16	19	22	24	28	32	35	38		
	DV	M6 x 20			M6 x 20			M6 x 20				
	NV	1			2			3				
	CH	5			5			5				
	CS [Nm]	16.2			16.2			16.2				

Tutte le viti hanno classe di resistenza 12.9
 All screws supplied according to strenght class 12.9
 Alle Schrauben nach Festigkeitsklasse 12.9 geliefert

AE= Albero entrata / Input shaft / Antriebswelle
 DV= Diametro vite / Screw diameter / Schraubendurchmesser

NV= Numero viti / Number of screw / Schraubenanzahl
 CS= Coppia di serraggio / Setting torque / Spannungsmoment

2.10 Istruzioni per il montaggio del motore

2.10 Instructions for assembly of motor

2.10 Anleitung für motormontage

2 Schema di montaggio / Assembly drawing / Bauanleitung 2

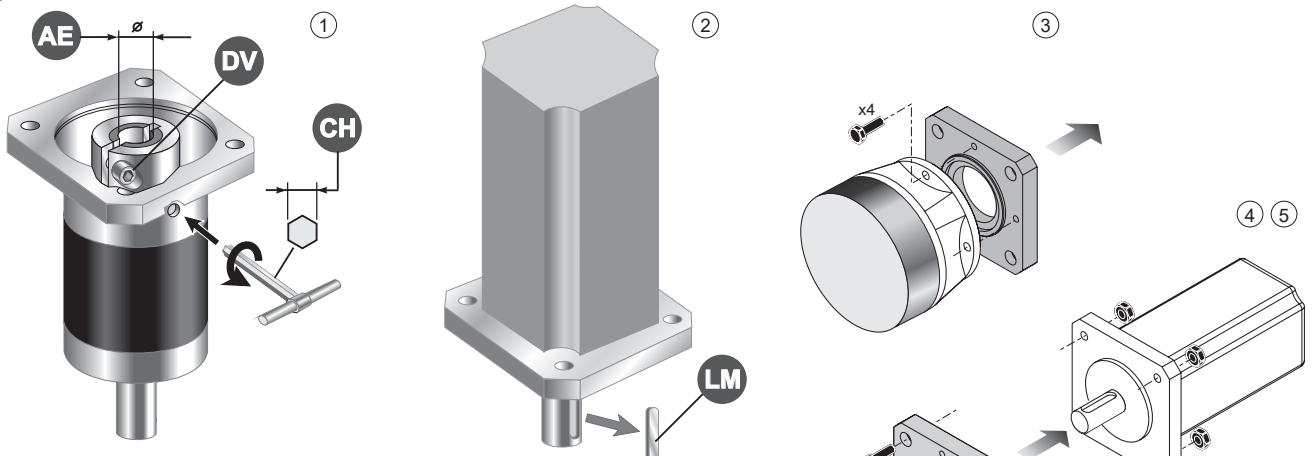

- 1 - Allentare la vite di serraggio del morsetto (DV)
- 2 - Estrarre la linguetta (LM) dall'albero motore
- 3 - Smontare la flangia dal riduttore
- 4 - Pulire le superfici di contatto delle flange motore e riduttore
- 5 - Fissare la flangia sul motore
- 6 - Calettare il motore sul riduttore evitando urti
- 7 - Stringere le viti di assemblaggio (FV) in modo alternato
- 8 - Assicurarsi che il morsetto venga serrato posizionandolo verso il motore e rispettando la fasatura dei tagli
- 9 - Serrare la vite (o le viti) del morsetto (DV) alla coppia (CS) indicata in tabella

- 1 - Unloose the fastening screw (or screws) of the clamp (DV)
- 2 - Remove the key (LM) from motor shaft
- 3 - Remove the flange from the gearbox
- 4 - Clean the contact surfaces of motor flange/gearbox flange
- 5 - Fix the flange on the motor
- 6 - Avoid impacts while fitting motor to gearbox
- 7 - Tighten the assembling screws (FV) alternatively
- 8 - Fix the clamp towards the motor and tighten it in compliance with the cuts timing
- 9 - Tighten the clamp screw, or screws (DV) according to the torque (CS) reported in the table

- 1 - die Befestigungsschraube der Klammer (DV) lockern
- 2 - die Feder (LM) aus Motorwelle ziehen
- 3 - die Flansch von Getriebe abmontieren
- 4 - die Motorflansch / Getriebe-flansch Kontaktfläche reinigen
- 5 - die Flansch an Motor befestigen
- 6 - Motor und Getriebe ohne Stöße verkeilen
- 7 - die Befestigungsschrauben (FV) abwechselnd anziehen
- 8 - Die Klammer soll zum Motor angezogen. Dabei soll die Zuendeinstellung de Schnitte geachtet
- 9 - die Schraube (oder Schrauben) der Klammer (DV) zu dem in der Tabelle angegebenen Anzugsmoment anziehen

EP 55	AE	6	6.35	7	8	9	9.52	11				
	DV	M4 x 16										
	NV	1										
	CH	3										
	CS [Nm]	4.8										
EP 75	AE	6	6.35	7	8	9	9.52	11	12	12.7	14	
	DV	M4 x 16										
	NV	1										
	CH	3										
	CS [Nm]	4.8										
EP 90	AE	9	9.52	11	12	12.7	14	15.87	16	19		
	DV	M4 x 16							M5 x 20			
	NV	1							1			
	CH	3							4			
	CS [Nm]	4.8							9.4			
EP 120	AE	12.7	14	15.87	16	19	22	24	25	28		
	DV	M4 x 16			M5 x 20			M6 x 20				
	NV	1			1			2				
	CH	3			4			5				
	CS [Nm]	4.8			9.4			16.2				
EP 155	AE	15.87	16	19	22	24	28	32	35	38		
	DV	M6 x 20			M6 x 20			M6 x 20				
	NV	1			2			3				
	CH	5			5			5				
	CS [Nm]	16.2			16.2			16.2				

Tutte le viti hanno classe di resistenza 12.9

All screws supplied according to strenght class 12.9

Alle Schrauben nach Festigkeitsklasse 12.9 geliefert

AE= Albero entrata / Input shaft / Antriebswelle

DV= Diametro vite / Screw diameter / Schraubendurchmesser

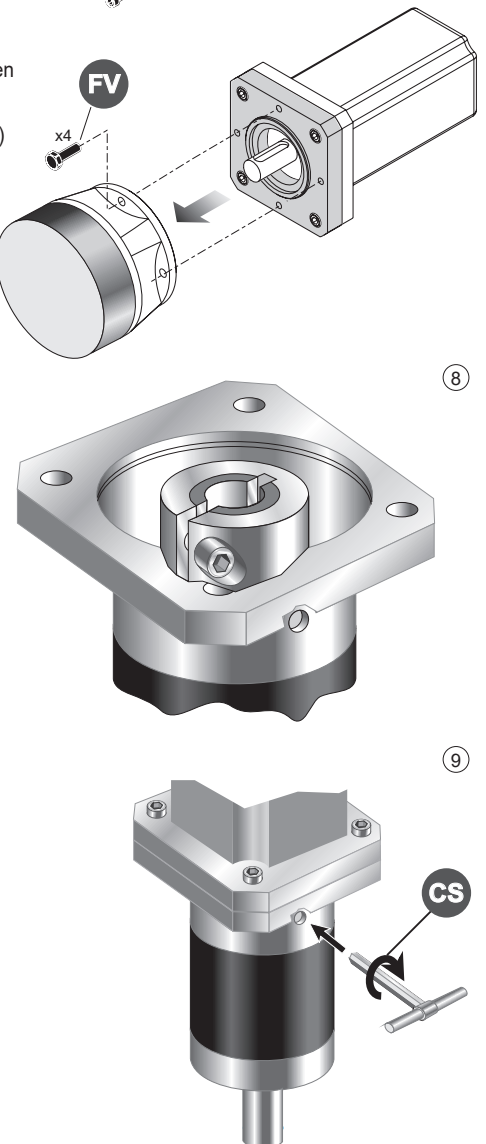

NV= Numero viti / Number of screw / Schraubenanzahl

CS= Coppia di serraggio / Setting torque / Spannungsmoment