

2.0	REDUCTORES TORNILLO SIN FIN X	X WORM GEARBOXES	RÉDUCTEUR À ROUE ET VIS SANS FIN X
2.1	Características	<i>Characteristics</i>	Caractéristiques 16
2.2	Nomenclatura	<i>Designation</i>	Désignation 17
2.3	Lubricación y posición de montaje	<i>Lubrication and mounting position</i>	Lubrification et positions de montage 18
2.4	Posición del tablero de Borne	<i>Terminal board position</i>	Position de la boîte à bornes 18
2.5	Datos técnicos	<i>Technical data</i>	Données techniques 19
2.6	Momento de inercia	<i>Moment of inertia</i>	Moments d'inertie 27
2.7	Tamaño	<i>Dimensions</i>	Dimensions 32
2.8	Entrada suplementaria	<i>Additional input</i>	Entrée supplémentaire 37
2.9	Limitador de par agujero pasante	<i>Torque limiter with through hollow shaft</i>	Limiteur de couple creux continu 37
2.10	Accesorios	<i>Accessories</i>	Accessoires 39
2.11	Lista de recambios	<i>Spare parts list</i>	Liste des pièces détachées 40

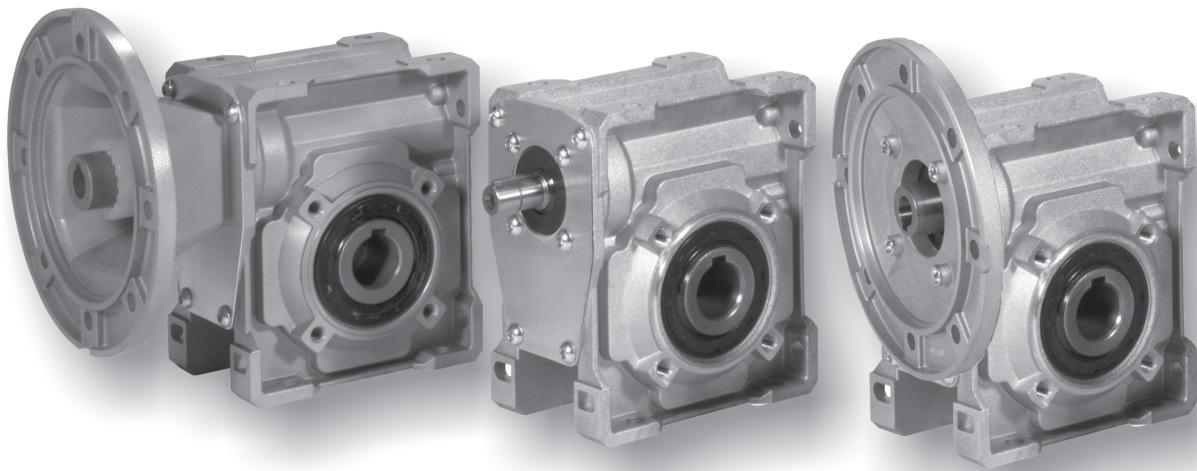

XF

XA

XC

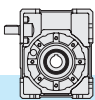

2.1 Características

- Los reductores de tornillo sin fin de la serie X están disponibles en las versiones con eje XA y con predisposición para enganche motor XF-XC.
- La versión XF (campana + junta), caracterizada por una amplia versatilidad en los distintos tipos de aplicaciones, presenta un mayor rendimiento con respecto a la serie XC, que a su vez, tiene la ventaja de ocupar un espacio menor.
- La carcasa monobloque es de hierro fundido para los tamaños 90, 110 y 130 y para los tamaños inferiores de aluminio fundido bajo presión 30, 40, 50, 63, 75, 89.
- Los tornillos sin fin son de acero aleado cementado templado y son rectificadas.
- Los dientes de los engranajes realizados en hierro fundido y el anillo en bronce.
- Las carcasas en hierro fundido pintadas de AZUL RAL 5010 mientras que las de aluminio pulidas a chorro de arena.
- Está incluido el eje de salida hueco de serie, con una amplia disponibilidad de accesorios: segunda entrada, cojinetes de bolas sobre el engranaje, brida de salida, eje lento con 1 y dos salidas, limitador de par con agujero pasante, brazo de reacción, kit de protección eje hueco, kit protección limitador de par.

2.1 Characteristics

- *X series worm gearboxes are available in the following versions : XA with shaft, XF and XC suitable for motor mounting assembling.*
- *The XF version (bell + joint) suits a wider range of applications and provides higher efficiency than the XC compact version, which actually offers reduced space requirement.*
- *The enbloc housing is in cast-iron for sizes 90, 110 and 130, in die-cast aluminium for smaller sizes 30, 40, 50, 63, 75, 89.*
- *The worm shaft is in case-and quench-hardened alloy steel and ground.*
- *The worm wheel has a cast-iron hub provided with inserted cast-bronze ring.*
- *The housings in cast iron are painted BLUE RAL 5010, those in aluminium are sandblasted.*
- *The hollow output shaft is supplied as standard. A broad range of accessories is available: second input, tapered roller bearings on the worm wheel, output flange, single or double-extended output shaft, torque limiter with through hollow shaft, torque arm, hollow shaft protection kit, torque limiter protection kit.*

2.1 Caractéristiques



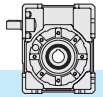





- Les réducteurs à roue et vis sans fin de la série X sont disponibles dans la version XA avec arbre et XF-XC avec accouplement moteur.
- La version XF (cloche+joint), caractérisée par une plus grande adaptation aux divers types d'application, a un rendement plus élevé par rapport à celui de la série compacte XC, qui offre par contre un encombrement limité.
- Les carters monoblocs de taille 90 et 110 sont en fonte, les tailles inférieures sont en alliage d'aluminium 30, 40, 50, 63, 75, 89.
- La vis sans fin est en acier cémenté et trempé. Le profil est rectifié.
- Le moyeu de la roue est en fonte avec un insert en bronze.
- Les carters en fonte sont livrés avec peinture BLEU RAL5010 tandis que ceux en aluminium sont sablés.
- L'arbre de sortie creux est fourni de série. De plus, il existe une vaste gamme d'accessoires: deuxième entrée, roulements coniques sur la roue, bride de sortie, arbre lent avec 1 ou 2 sorties, limiteur de couple creux continu, bras de réaction, kit de protection de l'arbre creux, kit de protection limiteur de couple.

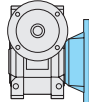
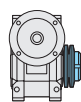

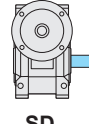
2.2 Nomenclatura

2.2 Designation

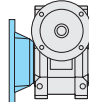
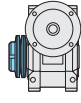
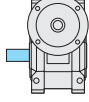
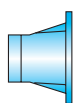
2.2 Désignation

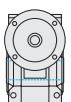
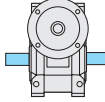
REDUCTORES / GEARBOX / REDUCTEUR											ACCESORIOS ACCESSORIES ACCESSOIRES	
Reductores Gearbox Réducteur	Tipo entrada Input type Type d'entrée	Tamaño Size Taille	Relación redu. Ratio Rapport de réduction	Enganche motor Motor coupling Prédisposition montage moteur	Posición montaje Mounting position Position Montage	Eje juego de salida Hollow output shaft Arbre de sortie creux	Brida de salida Output flange Bride de sortie	Limitador de par Torque limiter Limiteur de couple	Segunda entrada Additional input Deuxième entrée	Eje de salida Output shaft Arbre de sortie	Brazo de reacción Torque arm Bras de réaction	
X	A	50	10/1	P.A.M	B3	H25	F1S	LD	SeA	SD	BR	
Reductores de tornillo sin fin <i>Wormgearbox</i> Réducteur à roue et vis sans fin	 A	30 40 50 63 75 89*	5 7.5 10 15 20 25 30 40 50 65 80 100	56 63 71 80 90 100 112 132	B3, B6 B7, B8 V5, V6	ver tablas <i>see</i> <i>tables</i> voir les tableaux	 F1D-F2D-F3D	 LD	 SeA	 SD		
	 C	 Aluminio Aluminium Aluminium	90 110 130			 F1S-F2S-F3S	 LS			 SS		
	 F	 Hierro fundido Cast iron Fer				 F12-F22-F32				 DD		

Tipo entrada

Input type

Type d'entrée

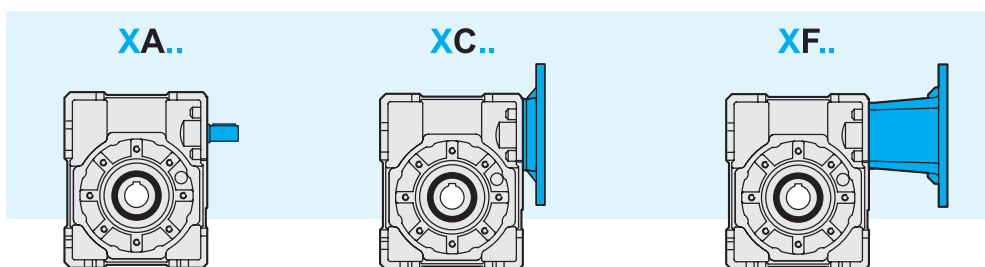



2.3 Lubricación

Los reductores de la serie X, excepto el tamaño 130, se entregan completos de lubricante sintético a base PAG con viscosidad ISO VG320. Se recomienda precisar ordenadamente las fases deseada de la posición de trabajo.

Para obtener más detalles, consulte el apartado 1.13 en la pág. 12.

2.3 Lubrication

X series worm gearboxes, except for the size 130, are supplied with synthetic lubricant, PAG base, viscosity index ISO VG320. Mounting position always to be specified when ordering.

For more details, see page 12, paragraph 1.13.

2.3 Lubrification

Les réducteurs à roue et vis sans fin de la série X, excepté la taille 130, sont livrés avec un lubrifiant synthétique à base PAG ayant un indice de viscosité ISO VG320. Position de montage à préciser lors de la commande.

Pour plus de détails, consulter le paragraphe 1.13 à la page 12.

Posición de montaje

Mounting positions

Positions de montage

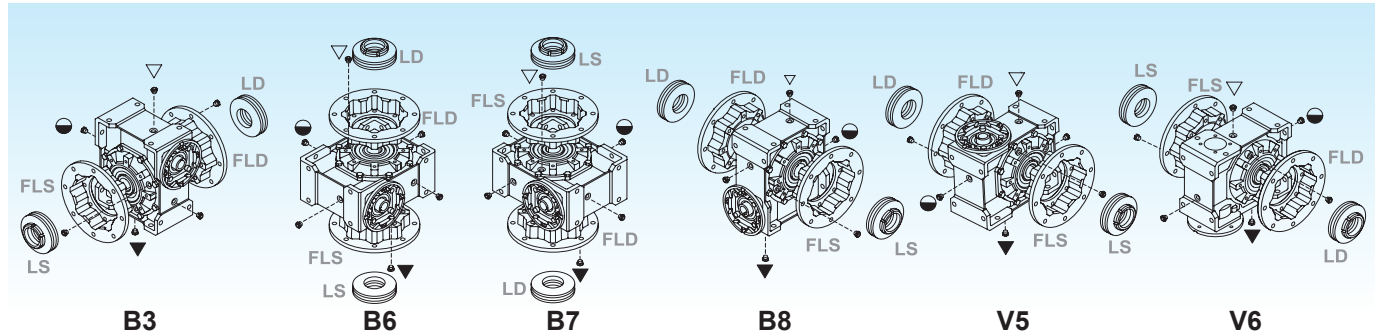

- ▽ Carga y respiradero / Filling and breather / Remplissage
- Nivel / Level / Niveau
- ▼ Descarga / Drain / Vidange

Los cuerpos de aluminio 30, 40, 50, 63, 75 y 89 tiene solamente un tapón de llenado para aceite.

30, 40, 50, 63, 75 and 89 aluminium housings have one oil filling plug only.

Les carters en aluminium 30, 40, 50, 63, 75, 89 ont un seul bouchon de remplissage.

		Cant. de aceite / Oil quantity / Q.té d'huile [lt]			
		Posición de montaje / Mounting position / Position de montage			
		B3	B6 - B7	B8	V5 - V6
X	30	0.015	0.030	0.015	
	40	0.040	0.060	0.040	
	50	0.080	0.120	0.080	
	63	0.160	0.220	0.160	
	75	0.260	0.340	0.260	
	89	0.450	0.750	0.450	
	90	1.1	0.9	1	1.5
	110	2.2	1.8	1.6	2.6
130	3.6	3	2.5	3.8	

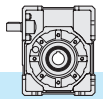

2.4 Posición borne

2.4 Terminal board position

2.4 Position de la boîte à bornes

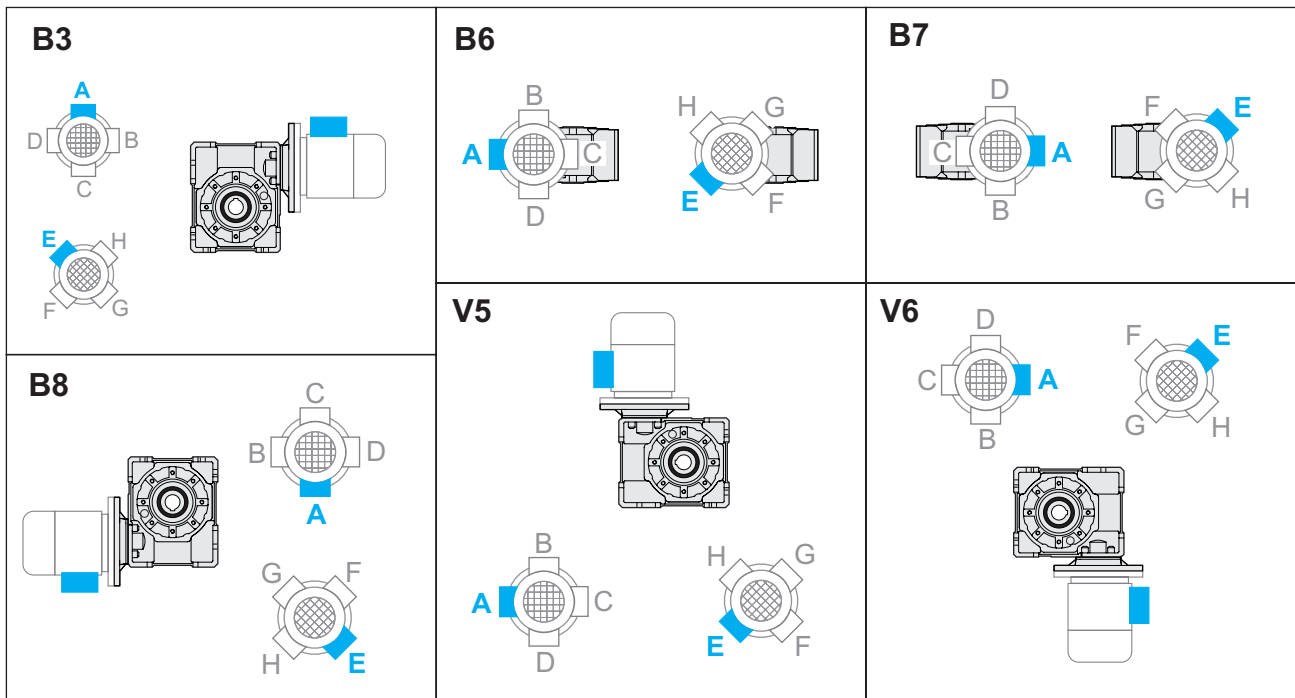

Especificar siempre ordenadamente la posición de montaje y su forma constructiva. Posición borne v. pag. 35-36 (PM=1; PM=2)

Mounting position always to be specified when ordering.
Terminal board position see page 35-36 (PM=1; PM=2)

Lors de toute commande, il est recommandé de préciser la position de montage et la version désirées. Position de la boîte à bornes v. pag. 35-36 (PM=1; PM=2)



2.5 Datos técnicos

2.5 Technical data

2.5 Données techniques

30	$n_1 = 2800$				XA		XC - XF								
	i_n	n_2 [min ⁻¹]	Rd	P_{10}	T_{2M} [Nm]	P [kW]	T_2 [Nm]	P_1 [kW]	FS'	Input - IEC					
										XC B5/B14	XF				
Kg 1.4	5	560	0.89	—	14	0.92	5.6	0.37	2.5	63	56	63	56	63	56
	7.5	373	0.86		16	0.72	8	0.37	2.0						
	10	280	0.84		16	0.56	11	0.37	1.5						
	15	187	0.81		17	0.41	15	0.37	1.1						
	20	140	0.76		15	0.29	13	0.25	1.2						
	25	112	0.74		16	0.25	16	0.25	1.0						
	30	93	0.71		13	0.18	13	0.18	1.0						
	40	70	0.65		16	0.18	16	0.18	1.0						
	50	56	0.62		15	0.14	14	0.13	1.1						
	65	43	0.57		17	0.13	17	0.13	1.0						
80	35	0.54	13	0.09	13	0.09	1.0								
100	28	0.52	12	0.07	16	0.09	0.8	—							

30	$n_1 = 1400$				XA		XC - XF								
	i_n	n_2 [min ⁻¹]	Rd	P_{10}	T_{2M} [Nm]	P [kW]	T_2 [Nm]	P_1 [kW]	FS'	Input - IEC					
										XC B5/B14	XF				
Kg 1.4	5	280	0.87	0.40	19	0.64	6.5	0.22	2.9	63	56	63	56	63	56
	7.5	187	0.84	0.40	21	0.49	9	0.22	2.2						
	10	140	0.82	0.40	22	0.40	12	0.22	1.8						
	15	93	0.77	0.30	22	0.28	17	0.22	1.3						
	20	70	0.72	0.20	19	0.19	18	0.18	1.1						
	25	56	0.69	0.20	21	0.18	21	0.18	1.0						
	30	47	0.66	0.20	20	0.15	18	0.13	1.1						
	40	35	0.59	0.20	21	0.13	21	0.13	1.0						
	50	28	0.55	0.20	19	0.10	17	0.09	1.1						
	65	22	0.51	0.10	20	0.09	20	0.09	1.0						
80	18	0.48	0.10	17	0.06	16	0.06	1.0							
100	14	0.45	0.10	14	0.05	18	0.06	0.8	—						

30	$n_1 = 900$				XA		XC - XF								
	i_n	n_2 [min ⁻¹]	Rd	P_{10}	T_{2M} [Nm]	P [kW]	T_2 [Nm]	P_1 [kW]	FS'	Input - IEC					
										XC B5/B14	XF				
Kg 1.4	5	180	0.85	—	23	0.51	5.9	0.13	3.9	63	56	63	56	63	56
	7.5	120	0.82		25	0.38	9	0.13	2.9						
	10	90	0.80		25	0.30	11	0.13	2.3						
	15	60	0.75		25	0.21	15	0.13	1.6						
	20	45	0.69		22	0.15	19	0.13	1.2						
	25	36	0.66		24	0.14	23	0.13	1.1						
	30	30	0.63		21	0.10	18	0.09	1.2						
	40	23	0.55		24	0.10	21	0.09	1.1						
	50	18	0.52		21	0.08	16	0.06	1.1						
	65	14	0.48		22	0.07	20	0.06	1.1						
80	11	0.44	19	0.05	11	0.03	1.7								
100	9	0.42	15	0.03	13	0.03	1.1	—							

30	$n_1 = 500$				XA		XC - XF								
	i_n	n_2 [min ⁻¹]	Rd	P_{10}	T_{2M} [Nm]	P [kW]	T_2 [Nm]	P_1 [kW]	FS'	Input - IEC					
										XC B5/B14	XF				
Kg 1.4	5	100	0.83	—	29	0.36	—	—	—	63	56	63	56	63	56
	7.5	67	0.80		31	0.27	—	—	—						
	10	50	0.77		31	0.21	—	—	—						
	15	33	0.72		31	0.15	—	—	—						
	20	25	0.66		26	0.10	—	—	—						
	25	20	0.62		27	0.09	—	—	—						
	30	17	0.59		25	0.07	—	—	—						
	40	13	0.51		28	0.07	—	—	—						
	50	10	0.48		25	0.06	—	—	—						
	65	8	0.43		25	0.05	—	—	—						
80	6	0.40	20	0.03	—	—	—								
100	5	0.38	16	0.02	—	—	—	—							

* **ATENCIÓN:** el par máximo utilizable [T_{2M}] deberá calcularse con respecto al factor de servicio: $T_{2M} = T_2 \times FS'$

* **WARNING:** Maximum allowable torque [T_{2M}] must be calculated using the following service factor: $T_{2M} = T_2 \times FS'$

* **ATTENTION :** le couple maximum admissible [T_{2M}] se calcule en utilisant le facteur de service suivant : $T_{2M} = T_2 \times FS'$

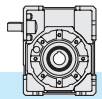

2.5 Datos técnicos

2.5 Technical data

2.5 Données techniques

40	n ₁ = 2800				XA		XC - XF											
	i _n	n ₂ [min. ⁻¹]	Rd	P ₁₀	T _{2M} [Nm]	P [kW]	T ₂ [Nm]	P ₁ [kW]	FS'	XC			Input - IEC					
										B5/B14			B5		XF			B14
2.4	5	560	0.88	—	25	1.67	11.3	0.75	2.2	71	63	—	71	63	56	71	63	—
	7.5	373	0.87		30	1.3	17	0.75	1.8									
	10	280	0.86		31	1.1	22	0.75	1.4									
	15	187	0.82		32	0.76	32	0.75	1.0									
	20	140	0.80		31	0.57	30	0.55	1.0									
	25	112	0.76		27	0.41	24	0.37	1.1									
	30	93	0.73		35	0.47	28	0.37	1.3									
	40	70	0.70		33	0.35	24	0.25	1.4									
	50	56	0.65		30	0.27	28	0.25	1.1									
	65	43	0.61		28	0.21	24	0.18	1.2									
2.4	80	35	0.58	26	0.16	21	0.13	1.3	—	—	56	—	—	—	—	—	—	
	100	28	0.55	25	0.13	24	0.13	1.0										

40	n ₁ = 1400				XA		XC - XF											
	i _n	n ₂ [min. ⁻¹]	Rd	P ₁₀	T _{2M} [Nm]	P [kW]	T ₂ [Nm]	P ₁ [kW]	FS'	XC			Input - IEC					
										B5/B14			B5		XF			B14
2.4	5	280	0.87	0.80	34	1.14	16.3	0.55	2.1	71	63	—	71	63	56	71	63	—
	7.5	187	0.85	0.80	40	0.92	24	0.55	1.7									
	10	140	0.83	0.70	41	0.73	31	0.55	1.3									
	15	93	0.79	0.50	42	0.52	30	0.37	1.4									
	20	70	0.76	0.50	40	0.39	38	0.37	1.0									
	25	56	0.72	0.40	35	0.29	31	0.25	1.1									
	30	47	0.68	0.40	41	0.29	35	0.25	1.2									
	40	35	0.64	0.30	38	0.22	38	0.22	1.0									
	50	28	0.59	0.30	38	0.19	36	0.18	1.1									
	65	22	0.54	0.20	35	0.15	31	0.13	1.1									
2.4	80	18	0.52	0.20	33	0.12	31	0.11	1.1	—	—	56	—	—	—	—	—	
	100	14	0.49	0.20	28	0.08	30	0.09	0.9									

40	n ₁ = 900				XA		XC - XF											
	i _n	n ₂ [min. ⁻¹]	Rd	P ₁₀	T _{2M} [Nm]	P [kW]	T ₂ [Nm]	P ₁ [kW]	FS'	XC			Input - IEC					
										B5/B14			B5		XF			B14
2.4	5	180	0.85	—	42	0.93	16.7	0.37	2.5	71	63	—	71	63	56	71	63	—
	7.5	120	0.83		48	0.72	25	0.37	2.0									
	10	90	0.81		48	0.56	32	0.37	1.5									
	15	60	0.76		49	0.40	45	0.37	1.1									
	20	45	0.74		46	0.29	39	0.25	1.2									
	25	36	0.69		42	0.23	33	0.18	1.3									
	30	30	0.65		48	0.23	37	0.18	1.3									
	40	23	0.61		42	0.16	33	0.13	1.3									
	50	18	0.55		42	0.14	38	0.13	1.1									
	65	14	0.51		39	0.11	32	0.09	1.2									
2.4	80	11	0.48	37	0.09	37	0.09	1.0	—	—	56	—	—	—	—	—	—	
	100	9	0.45	30	0.06	29	0.06	1.0										

40	n ₁ = 500				XA		XC - XF											
	i _n	n ₂ [min. ⁻¹]	Rd	P ₁₀	T _{2M} [Nm]	P [kW]	T ₂ [Nm]	P ₁ [kW]	FS'	XC			Input - IEC					
										B5/B14			B5		XF			B14
2.4	5	100	0.83	—	51	0.64	7.1	0.09	7.1	71	63	—	71	63	56	71	63	—
	7.5	67	0.81		58	0.50	10	0.09	5.5									
	10	50	0.79		59	0.39	14	0.09	4.4									
	15	33	0.73		59	0.28	19	0.09	3.1									
	20	25	0.70		55	0.20	24	0.09	2.3									
	25	20	0.65		48	0.15	28	0.09	1.7									
	30	17	0.61		58	0.17	31	0.09	1.8									
	40	13	0.57		52	0.12	39	0.09	1.3									
	50	10	0.51		51	0.11	44	0.09	1.2									
	65	8	0.46		45	0.08	52	0.09	0.9									
2.4	80	6	0.44	42	0.06	61*	0.09	0.7*	—	—	56	—	—	—	—	—	—	
	100	5	0.41	32	0.04	71*	0.09	0.4*										

* **ATENCIÓN:** el par máximo utilizable [T_{2M}] deberá calcularse con respecto al factor de servicio: T_{2M} = T₂ x FS'

* **WARNING:** Maximum allowable torque [T_{2M}] must be calculated using the following service factor: T_{2M} = T₂ x FS'

* **ATTENTION:** le couple maximum admissible [T_{2M}] se calcule en utilisant le facteur de service suivant: T_{2M} = T₂ x FS'



2.5 Datos técnicos

2.5 Technical data

2.5 Données techniques

50	$n_1 = 2800$				XA		XC - XF											
	i_n	n_2 [min. ⁻¹]	Rd	P_{10}	T_{2M} [Nm]	P [kW]	T_2 [Nm]	P_1 [kW]	FS'	Input - IEC								
										XC			XF					
	B5/B14			B5			B14											
4.0	5	560	0.89	—	44	2.9	22.8	1.5	1.9	80	71	—	80	71	63	80	71	—
	7.5	373	0.88		51	2.3	34	1.5	1.5									
	10	280	0.86		54	1.8	44	1.5	1.2									
	15	187	0.84		57	1.3	47	1.1	1.2									
	20	140	0.81		58	1.0	42	0.75	1.4									
	25	112	0.78		50	0.75	50	0.75	1.0									
	30	93	0.75		55	0.71	42	0.55	1.3									
	40	70	0.72		54	0.63	54	0.55	1.0									
	50	56	0.68		56	0.48	43	0.37	1.3									
	65	43	0.64		53	0.37	53	0.37	1.0									
	80	35	0.61		48	0.29	41	0.25	1.2									
	100	28	0.58		45	0.23	35	0.18	1.3									

50	$n_1 = 1400$				XA		XC - XF											
	i_n	n_2 [min. ⁻¹]	Rd	P_{10}	T_{2M} [Nm]	P [kW]	T_2 [Nm]	P_1 [kW]	FS'	Input - IEC								
										XC			XF					
	B5/B14			B5			B14											
4.0	5	280	0.87	1.2	62	2.1	26.7	0.9	2.3	80	71	—	80	71	63	80	71	—
	7.5	187	0.86	1.2	70	1.6	40	0.9	1.8									
	10	140	0.84	1.0	73	1.3	52	0.9	1.4									
	15	93	0.80	0.80	74	0.90	74	0.9	1.0									
	20	70	0.78	0.70	75	0.71	58	0.55	1.3									
	25	56	0.74	0.60	65	0.51	47	0.37	1.4									
	30	47	0.71	0.60	66	0.46	53	0.37	1.2									
	40	35	0.67	0.50	69	0.38	68	0.37	1.0									
	50	28	0.62	0.40	70	0.33	53	0.25	1.3									
	65	22	0.58	0.40	64	0.25	64	0.25	1.0									
	80	18	0.54	0.40	60	0.20	53	0.18	1.1									
	100	14	0.51	0.30	55	0.16	45	0.13	1.2									

50	$n_1 = 900$				XA		XC - XF											
	i_n	n_2 [min. ⁻¹]	Rd	P_{10}	T_{2M} [Nm]	P [kW]	T_2 [Nm]	P_1 [kW]	FS'	Input - IEC								
										XC			XF					
	B5/B14			B5			B14											
4.0	5	180	0.85	—	75	1.66	33.8	0.75	2.2	80	71	—	80	71	63	80	71	—
	7.5	120	0.84		83	1.23	50	0.75	1.6									
	10	90	0.82		86	0.98	66	0.75	1.3									
	15	60	0.78		88	0.71	68	0.55	1.3									
	20	45	0.75		87	0.54	59	0.37	1.5									
	25	36	0.71		75	0.40	70	0.37	1.1									
	30	30	0.67		79	0.37	79	0.37	1.0									
	40	23	0.63		75	0.28	67	0.25	1.1									
	50	18	0.59		80	0.26	78	0.25	1.0									
	65	14	0.54		74	0.20	67	0.18	1.1									
	80	11	0.51		67	0.16	56	0.13	1.2									
	100	9	0.47		58	0.12	45	0.09	1.3									

50	$n_1 = 500$				XA		XC - XF											
	i_n	n_2 [min. ⁻¹]	Rd	P_{10}	T_{2M} [Nm]	P [kW]	T_2 [Nm]	P_1 [kW]	FS'	Input - IEC								
										XC			XF					
	B5/B14			B5			B14											
4.0	5	100	0.84	—	92	1.15	14.3	0.18	6.4	80	71	—	80	71	63	80	71	—
	7.5	67	0.82		100	0.85	21	0.18	4.7									
	10	50	0.80		104	0.68	28	0.18	3.8									
	15	33	0.75		106	0.49	39	0.18	2.7									
	20	25	0.72		104	0.38	50	0.18	2.1									
	25	20	0.68		88	0.27	58	0.18	1.5									
	30	17	0.63		98	0.27	65	0.18	1.5									
	40	13	0.59		95	0.21	81	0.18	1.2									
	50	10	0.54		94	0.18	93	0.18	1.0									
	65	8	0.50		86	0.14	56	0.09	1.5									
	80	6	0.46		77	0.11	63	0.09	1.2									
	100	5	0.43		61	0.07	74	0.09	0.8									

* **ATENCIÓN:** el par máximo utilizable [T_{2M}] deberá calcularse con respecto al factor de servicio: $T_{2M} = T_2 \times FS'$

* **WARNING:** Maximum allowable torque [T_{2M}] must be calculated using the following service factor: $T_{2M} = T_2 \times FS'$

* **ATTENTION :** le couple maximum admissible [T_{2M}] se calcule en utilisant le facteur de service suivant : $T_{2M} = T_2 \times FS'$

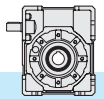

2.5 Datos técnicos

2.5 Technical data

2.5 Données techniques

63	$n_1 = 2800$				XA		XC - XF										
	i_n	n_2 [min ⁻¹]	Rd	P_{t0}	T_{2M} [Nm]	P [kW]	T_2 [Nm]	P_1 [kW]	FS'	Input - IEC							
										XC			XF				
	B5/B14			B5			B14										
5	560	0.89	—	79	5.2	45.5	3	1.7	90	80	—	90	80	71	90	80	—
7.5	373	0.88		88	3.9	68	3	1.3									
10	280	0.87		94	3.2	89	3	1.1									
15	187	0.84		98	2.3	95	2.2	1.0									
20	140	0.83		110	1.9	85	1.5	1.3									
25	112	0.81		93	1.4	76	1.1	1.2									
30	93	0.77		110	1.4	87	1.1	1.3									
40	70	0.74		117	1.2	111	1.1	1.1									
50	56	0.70		97	0.81	90	0.75	1.1									
65	43	0.67		98	0.66	81	0.55	1.2									
80	35	0.64		91	0.52	65	0.37	1.4									
100	28	0.60		83	0.41	75	0.37	1.1									

 6.6

63	$n_1 = 1400$				XA		XC - XF										
	i_n	n_2 [min ⁻¹]	Rd	P_{t0}	T_{2M} [Nm]	P [kW]	T_2 [Nm]	P_1 [kW]	FS'	Input - IEC							
										XC			XF				
	B5/B14			B5			B14										
5	280	0.88	1.8	111	3.7	54	1.8	2.0	90	80	—	90	80	71	90	80	—
7.5	187	0.87	1.8	120	2.7	80	1.8	1.5									
10	140	0.85	1.6	127	2.2	105	1.8	1.2									
15	93	0.81	1.2	130	1.6	125	1.5	1.1									
20	70	0.80	1.2	144	1.3	120	1.1	1.2									
25	56	0.77	1.0	118	0.90	118	0.9	1.0									
30	47	0.73	0.90	142	0.95	134	0.9	1.1									
40	35	0.69	0.80	150	0.79	142	0.75	1.1									
50	28	0.65	0.70	122	0.55	122	0.55	1.0									
65	22	0.61	0.60	122	0.45	100	0.37	1.2									
80	18	0.58	0.60	113	0.36	79	0.25	1.4									
100	14	0.53	0.50	102	0.28	91	0.25	1.1									

 6.6

63	$n_1 = 900$				XA		XC - XF										
	i_n	n_2 [min ⁻¹]	Rd	P_{t0}	T_{2M} [Nm]	P [kW]	T_2 [Nm]	P_1 [kW]	FS'	Input - IEC							
										XC			XF				
	B5/B14			B5			B14										
5	180	0.87	—	135	2.9	69	1.5	1.9	90	80	—	90	80	71	90	80	—
7.5	120	0.85		144	2.1	102	1.5	1.4									
10	90	0.83		150	1.7	133	1.5	1.1									
15	60	0.79		152	1.2	139	1.1	1.1									
20	45	0.77		167	1.0	123	0.75	1.4									
25	36	0.74		140	0.71	109	0.55	1.3									
30	30	0.70		164	0.74	122	0.55	1.3									
40	23	0.66		171	0.61	154	0.55	1.1									
50	18	0.61		141	0.44	120	0.37	1.2									
65	14	0.57		139	0.35	98	0.25	1.4									
80	11	0.54		128	0.28	115	0.25	1.1									
100	9	0.50		115	0.22	95	0.18	1.2									

 6.6

63	$n_1 = 500$				XA		XC - XF										
	i_n	n_2 [min ⁻¹]	Rd	P_{t0}	T_{2M} [Nm]	P [kW]	T_2 [Nm]	P_1 [kW]	FS'	Input - IEC							
										XC			XF				
	B5/B14			B5			B14										
5	100	0.85	—	169	2.08	20	0.25	8.3	90	80	—	90	80	71	90	80	—
7.5	67	0.83		177	1.5	30	0.25	5.9									
10	50	0.81		182	1.2	39	0.25	4.7									
15	33	0.76		184	0.84	55	0.25	3.4									
20	25	0.74		200	0.70	71	0.25	2.8									
25	20	0.71		165	0.49	85	0.25	1.9									
30	17	0.65		195	0.52	94	0.25	2.1									
40	13	0.62		201	0.43	118	0.25	1.7									
50	10	0.56		165	0.31	135	0.25	1.2									
65	8	0.52		161	0.25	163	0.25	1.0									
80	6	0.50		148	0.19	137	0.18	1.1									
100	5	0.45		122	0.14	77	0.09	1.6									

 6.6

* **ATENCIÓN:** el par máximo utilizable $[T_{2M}]$ deberá calcularse con respecto al factor de servicio: $T_{2M} = T_2 \times FS'$

* **WARNING:** Maximum allowable torque $[T_{2M}]$ must be calculated using the following service factor: $T_{2M} = T_2 \times FS'$

* **ATTENTION:** le couple maximum admissible $[T_{2M}]$ se calcule en utilisant le facteur de service suivant: $T_{2M} = T_2 \times FS'$



2.5 Datos técnicos

2.5 Technical data

2.5 Données techniques

75	$n_1 = 2800$				XA		XC - XF												
	i_n	n_2 [min ⁻¹]	Rd	P_{t0}	T_{2M} [Nm]	P [kW]	T_2 [Nm]	P_1 [kW]	FS'	Input - IEC									
										XC			XF						
	B5/B14			B5			B14												
7.5	373	0.89	—	131	5.8	125	5.5	1.0	112 100	90	—	—	112 100	90	80	112 100	90	—	
10	280	0.88		143	4.8	120	4	1.2											
15	187	0.85		152	3.5	131	3	1.2											
20	140	0.84		172	3.0	171	3	1.0											
25	112	0.82		155	2.2	154	2.2	1.0											
30	93	0.78		170	2.1	120	1.5	1.4											
40	70	0.75		183	1.8	154	1.5	1.2											
50	56	0.73		166	1.3	136	1.1	1.2											
65	43	0.69		155	1.0	114	0.75	1.4											
80	35	0.66		145	0.80	135	0.75	1.1											
100	28	0.62		131	0.62	159	0.75	0.8											



75	$n_1 = 1400$				XA		XC - XF												
	i_n	n_2 [min ⁻¹]	Rd	P_{t0}	T_{2M} [Nm]	P [kW]	T_2 [Nm]	P_1 [kW]	FS'	Input - IEC									
										XC			XF						
	B5/B14			B5			B14												
7.5	187	0.87	2.5	180	4.0	178	4	1.0	112 100	90	—	—	112 100	90	80	112 100	90	—	
10	140	0.86	2.3	193	3.3	176	3	1.1											
15	93	0.83	1.9	202	2.4	187	2.2	1.1											
20	70	0.81	1.7	226	2.0	199	1.8	1.1											
25	56	0.78	1.5	202	1.5	200	1.5	1.0											
30	47	0.74	1.2	220	1.5	167	1.1	1.3											
40	35	0.71	1.1	235	1.2	213	1.1	1.1											
50	28	0.67	1.0	211	0.92	206	0.9	1.0											
65	22	0.63	0.90	195	0.70	154	0.55	1.3											
80	18	0.60	0.80	182	0.55	180	0.55	1.0											
100	14	0.56	0.70	162	0.43	210	0.55	0.8											



75	$n_1 = 900$				XA		XC - XF												
	i_n	n_2 [min ⁻¹]	Rd	P_{t0}	T_{2M} [Nm]	P [kW]	T_2 [Nm]	P_1 [kW]	FS'	Input - IEC									
										XC			XF						
	B5/B14			B5			B14												
7.5	120	0.86	—	215	3.1	205	3	1.0	112 100	90	—	—	112 100	90	80	112 100	90	—	
10	90	0.84		229	2.6	197	2.2	1.2											
15	60	0.81		237	1.9	231	1.8	1.0											
20	45	0.78		263	1.6	250	1.5	1.1											
25	36	0.76		233	1.2	221	1.1	1.1											
30	30	0.71		254	1.1	249	1.1	1.0											
40	23	0.67		270	0.94	214	0.75	1.3											
50	18	0.64		241	0.71	186	0.55	1.3											
65	14	0.59		221	0.54	151	0.37	1.5											
80	11	0.56		205	0.43	177	0.37	1.2											
100	9	0.52		184	0.34	203	0.37	0.9											



75	$n_1 = 500$				XA		XC - XF												
	i_n	n_2 [min ⁻¹]	Rd	P_{t0}	T_{2M} [Nm]	P [kW]	T_2 [Nm]	P_1 [kW]	FS'	Input - IEC									
										XC			XF						
	B5/B14			B5			B14												
7.5	67	0.84	—	265	2.2	90	0.75	2.9	112 100	90	—	—	112 100	90	80	112 100	90	—	
10	50	0.82		279	1.8	118	0.75	2.4											
15	33	0.78		286	1.3	167	0.75	1.7											
20	25	0.75		315	1.1	216	0.75	1.5											
25	20	0.72		278	0.80	260	0.75	1.1											
30	17	0.67		302	0.79	288	0.75	1.1											
40	13	0.63		317	0.66	265	0.55	1.2											
50	10	0.59		282	0.50	210	0.37	1.3											
65	8	0.55		257	0.38	251	0.37	1.0											
80	6	0.52		238	0.30	197	0.25	1.2											
100	5	0.47		206	0.23	161	0.18	1.3											



* **ATENCIÓN:** el par máximo utilizable $[T_{2M}]$ deberá calcularse con respecto al factor de servicio: $T_{2M} = T_2 \times FS'$

* **WARNING:** Maximum allowable torque $[T_{2M}]$ must be calculated using the following service factor: $T_{2M} = T_2 \times FS'$

* **ATTENTION :** le couple maximum admissible $[T_{2M}]$ se calcule en utilisant le facteur de service suivant : $T_{2M} = T_2 \times FS'$

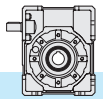

2.5 Datos técnicos

2.5 Technical data

2.5 Données techniques

89	n₁ = 2800				XC					
	i _n	n ₂ [min. ⁻¹]	Rd	P _{t0}	T ₂ [Nm]	P ₁ [kW]	FS'	Input - IEC		
								XC B5/B14		
Kg 13.0	7.5	373	0.89	—	171	7.5	1.2	112 100	90	—
	10	280	0.88		165	5.5	1.3			
	15	187	0.86		241	5.5	1.0			
	20	140	0.84		230	4	1.2			
	25	112	0.83		212	3	1.2			
	30	93	0.79		243	3	1.1			
	40	70	0.77		230	2.2	1.3	—	80	
	50	56	0.74		278	2.2	1.0			
	65	43	0.71		235	1.5	1.1			
	80	35	0.68		205	1.1	1.2			
100	28	0.64	163	0.75	1.3					

89	n₁ = 1400				XC					
	i _n	n ₂ [min. ⁻¹]	Rd	P _{t0}	T ₂ [Nm]	P ₁ [kW]	FS'	Input - IEC		
								XC B5/B14		
Kg 13.0	7.5	187	0.88	3.0	247	5.5	1.2	112 100	90	—
	10	140	0.86	2.5	236	4	1.3			
	15	93	0.84	2.2	256	3	1.2			
	20	70	0.82	2.0	334	3	1.1			
	25	56	0.80	1.8	299	2.2	1.1			
	30	47	0.76	1.5	340	2.2	1.0			
	40	35	0.72	1.3	355	1.8	1.1	—	80	
	50	28	0.69	1.1	353	1.5	1.0			
	65	22	0.65	1.0	317	1.1	1.0			
	80	18	0.63	1.0	309	0.9	1.0			
100	14	0.58	0.80	217	0.55	1.2				

89	n₁ = 900				XC					
	i _n	n ₂ [min. ⁻¹]	Rd	P _{t0}	T ₂ [Nm]	P ₁ [kW]	FS'	Input - IEC		
								XC B5/B14		
Kg 13.0	7.5	120	0.86	—	206	3	1.7	112 100	90	—
	10	90	0.85		270	3	1.3			
	15	60	0.82		286	2.2	1.3			
	20	45	0.79		371	2.2	1.1			
	25	36	0.77		369	1.8	1.0			
	30	30	0.73		416	1.8	1.0			
	40	23	0.69		440	1.5	1.0	—	80	
	50	18	0.66		384	1.1	1.0			
	65	14	0.62		319	0.75	1.1			
	80	11	0.59		274	0.55	1.2			
100	9	0.54	313	0.55	1.0					

89	n₁ = 500				XC					
	i _n	n ₂ [min. ⁻¹]	Rd	P _{t0}	T ₂ [Nm]	P ₁ [kW]	FS'	Input - IEC		
								XC B5/B14		
Kg 13.0	7.5	67	0.84	—	91	0.75	4.7	112 100	90	—
	10	50	0.83		118	0.75	3.7			
	15	33	0.79		169	0.75	2.7			
	20	25	0.76		219	0.75	2.3			
	25	20	0.74		265	0.75	1.7			
	30	17	0.68		294	0.75	1.6			
	40	13	0.65		371	0.75	1.4	—	80	
	50	10	0.61		439	0.75	1.1			
	65	8	0.57		388	0.55	1.1			
	80	6	0.54		305	0.37	1.3			
100	5	0.49	344	0.37	1.0					

* **ATENCIÓN:** el par máximo utilizable [T_{2M}] deberá calcularse con respecto al factor de servicio: T_{2M} = T₂ x FS'

* **WARNING:** Maximum allowable torque [T_{2M}] must be calculated using the following service factor : T_{2M} = T₂ x FS'

* **ATTENTION :** le couple maximum admissible [T_{2M}] se calcule en utilisant le facteur de service suivant : T_{2M} = T₂ x FS'

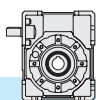

2.5 Datos técnicos

2.5 Technical data

2.5 Données techniques

90	$n_1 = 2800$				XA		XC - XF											
	i_n	n_2 [min ⁻¹]	Rd	P_{10}	T_{2M} [Nm]	P [kW]	T_2 [Nm]	P_1 [kW]	FS'	XC		Input - IEC						
										B5/B14		B5			XF			
Kg 23.6	7.5	373	0.89	—	209	9.2	171	7.5	1.2	112 100	90	—	112 100	90	80	112 100	90	—
	10	280	0.88		223	7.4	165	5.5	1.3									
	15	187	0.86		241	5.5	241	5.5	1.0									
	20	140	0.84		272	4.7	230	4	1.2									
	25	112	0.83		255	3.6	212	3	1.2									
	30	93	0.79		270	3.3	243	3	1.1									
	40	70	0.77		293	2.8	230	2.2	1.3									
	50	56	0.74		278	2.2	278	2.2	1.0									
	65	43	0.71		250	1.6	235	1.5	1.1									
	80	35	0.68		238	1.3	205	1.1	1.2									
100	28	0.64	212	0.97	163	0.75	1.3	—	80									

90	$n_1 = 1400$				XA		XC - XF											
	i_n	n_2 [min ⁻¹]	Rd	P_{10}	T_{2M} [Nm]	P [kW]	T_2 [Nm]	P_1 [kW]	FS'	XC		Input - IEC						
										B5/B14		B5			XF			
Kg 23.6	7.5	187	0.88	3.0	290	6.5	247	5.5	1.2	112 100	90	—	112 100	90	80	112 100	90	—
	10	140	0.86	2.5	305	5.2	236	4	1.3									
	15	93	0.84	2.2	320	3.7	256	3	1.2									
	20	70	0.82	2.0	360	3.2	334	3	1.1									
	25	56	0.80	1.8	332	2.4	299	2.2	1.1									
	30	47	0.76	1.5	350	2.3	340	2.2	1.0									
	40	35	0.72	1.3	377	1.9	355	1.8	1.1									
	50	28	0.69	1.1	353	1.5	353	1.5	1.0									
	65	22	0.65	1.0	317	1.1	317	1.1	1.0									
	80	18	0.63	1.0	309	0.90	309	0.9	1.0									
100	14	0.58	0.80	264	0.67	217	0.55	1.2	—	80								

90	$n_1 = 900$				XA		XC - XF											
	i_n	n_2 [min ⁻¹]	Rd	P_{10}	T_{2M} [Nm]	P [kW]	T_2 [Nm]	P_1 [kW]	FS'	XC		Input - IEC						
										B5/B14		B5			XF			
Kg 23.6	7.5	120	0.86	—	345	5.0	206	3	1.7	112 100	90	—	112 100	90	80	112 100	90	—
	10	90	0.85		362	4.0	270	3	1.3									
	15	60	0.82		377	2.9	286	2.2	1.3									
	20	45	0.79		419	2.5	371	2.2	1.1									
	25	36	0.77		385	1.9	369	1.8	1.0									
	30	30	0.73		416	1.8	416	1.8	1.0									
	40	23	0.69		440	1.5	440	1.5	1.0									
	50	18	0.66		398	1.1	384	1.1	1.0									
	65	14	0.62		358	0.84	319	0.75	1.1									
	80	11	0.59		337	0.68	274	0.55	1.2									
100	9	0.54	313	0.55	313	0.55	1.0	—	80									

90	$n_1 = 500$				XA		XC - XF											
	i_n	n_2 [min ⁻¹]	Rd	P_{10}	T_{2M} [Nm]	P [kW]	T_2 [Nm]	P_1 [kW]	FS'	XC		Input - IEC						
										B5/B14		B5			XF			
Kg 23.6	7.5	67	0.84	—	430	3.6	91	0.75	4.7	112 100	90	—	112 100	90	80	112 100	90	—
	10	50	0.83		443	2.8	118	0.75	3.7									
	15	33	0.79		456	2.0	169	0.75	2.7									
	20	25	0.76		502	1.7	219	0.75	2.3									
	25	20	0.74		459	1.3	265	0.75	1.7									
	30	17	0.68		483	1.2	294	0.75	1.6									
	40	13	0.65		512	1.0	371	0.75	1.4									
	50	10	0.61		467	0.80	439	0.75	1.1									
	65	8	0.57		417	0.59	388	0.55	1.1									
	80	6	0.54		391	0.48	305	0.37	1.3									
100	5	0.49	345	0.37	344	0.37	1.0	—	80									

* **ATENCIÓN:** el par máximo utilizable [T_{2M}] deberá calcularse con respecto al factor de servicio: $T_{2M} = T_2 \times FS'$

* **WARNING:** Maximum allowable torque [T_{2M}] must be calculated using the following service factor: $T_{2M} = T_2 \times FS'$

* **ATTENTION :** le couple maximum admissible [T_{2M}] se calcule en utilisant le facteur de service suivant : $T_{2M} = T_2 \times FS'$

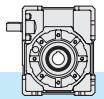

2.5 Datos técnicos

2.5 Technical data

2.5 Données techniques

110	$n_1 = 2800$				XA		XC - XF											
	i_n	n_2 [min ⁻¹]	Rd	P_{10}	T_{2M} [Nm]	P [kW]	T_2 [Nm]	P_1 [kW]	FS'	Input - IEC								
										XC			XF					
	B5/B14			B5		B14												
Kg 44.0	7.5	373	0.89	—	345	15.1	343	15	1.0	132	112 100	—	132	112 100	90	132	—	—
	10	280	0.88		368	12.2	332	11	1.1									
	15	187	0.86		404	9.2	331	7.5	1.2									
	20	140	0.85		465	8.0	435	7.5	1.1									
	25	112	0.84		441	6.2	393	5.5	1.1									
	30	93	0.80		459	5.6	450	5.5	1.0									
	40	70	0.78		503	4.7	424	4	1.2									
	50	56	0.76		476	3.7	388	3	1.2									
	65	43	0.73		417	2.6	354	2.2	1.2									
	80	35	0.70		400	2.1	287	1.5	1.4									
100	28	0.66	364	1.6	339	1.5	1.1	—	90	—	—	—	—	—	—	—		

110	$n_1 = 1400$				XA		XC - XF											
	i_n	n_2 [min ⁻¹]	Rd	P_{10}	T_{2M} [Nm]	P [kW]	T_2 [Nm]	P_1 [kW]	FS'	Input - IEC								
										XC			XF					
	B5/B14			B5		B14												
Kg 44.0	7.5	187	0.88	4.3	480	10.6	415	9.2	1.2	132	112 100	—	132	112 100	90	132	—	—
	10	140	0.87	4.0	504	8.5	446	7.5	1.1									
	15	93	0.84	3.2	543	6.3	475	5.5	1.1									
	20	70	0.83	3.0	623	5.5	623	5.5	1.0									
	25	56	0.81	2.7	578	4.2	554	4	1.0									
	30	47	0.77	2.2	601	3.8	472	3	1.3									
	40	35	0.74	2.0	650	3.2	606	3	1.1									
	50	28	0.72	1.8	608	2.5	538	2.2	1.1									
	65	22	0.68	1.6	528	1.8	451	1.5	1.2									
	80	18	0.65	1.5	503	1.4	390	1.1	1.3									
100	14	0.61	1.3	458	1.1	458	1.1	1.0	—	90	—	—	—	—	—	—		

110	$n_1 = 900$				XA		XC - XF											
	i_n	n_2 [min ⁻¹]	Rd	P_{10}	T_{2M} [Nm]	P [kW]	T_2 [Nm]	P_1 [kW]	FS'	Input - IEC								
										XC			XF					
	B5/B14			B5		B14												
Kg 44.0	7.5	120	0.87	—	578	8.3	381	5.5	1.5	132	112 100	—	132	112 100	90	132	—	—
	10	90	0.86		600	6.6	500	5.5	1.2									
	15	60	0.83		641	4.9	526	4	1.2									
	20	45	0.81		720	4.2	685	4	1.1									
	25	36	0.79		672	3.2	628	3	1.1									
	30	30	0.74		697	2.9	520	2.2	1.3									
	40	23	0.71		749	2.5	664	2.2	1.1									
	50	18	0.68		697	1.9	653	1.8	1.1									
	65	14	0.64		603	1.4	487	1.1	1.2									
	80	11	0.61		571	1.1	570	1.1	1.0									
100	9	0.57	513	0.85	450	0.75	1.1	—	90	—	—	—	—	—	—	—		

110	$n_1 = 500$				XA		XC - XF											
	i_n	n_2 [min ⁻¹]	Rd	P_{10}	T_{2M} [Nm]	P [kW]	T_2 [Nm]	P_1 [kW]	FS'	Input - IEC								
										XC			XF					
	B5/B14			B5		B14												
Kg 44.0	7.5	67	0.85	—	718	5.9	183	1.5	3.9	132	112 100	—	132	112 100	90	132	—	—
	10	50	0.84		738	4.6	240	1.5	3.1									
	15	33	0.80		778	3.4	344	1.5	2.3									
	20	25	0.78		866	2.9	446	1.5	1.9									
	25	20	0.76		802	2.2	542	1.5	1.5									
	30	17	0.70		832	2.1	603	1.5	1.4									
	40	13	0.67		886	1.7	765	1.5	1.2									
	50	10	0.64		820	1.3	671	1.1	1.2									
	65	8	0.59		705	0.96	553	0.75	1.3									
	80	6	0.56		664	0.77	643	0.75	1.0									
100	5	0.52	594	0.60	542	0.55	1.1	—	90	—	—	—	—	—	—	—		

* **ATENCIÓN:** el par máximo utilizable [T_{2M}] deberá calcularse con respecto al factor de servicio: $T_{2M} = T_2 \times FS'$

* **WARNING:** Maximum allowable torque [T_{2M}] must be calculated using the following service factor: $T_{2M} = T_2 \times FS'$

* **ATTENTION :** le couple maximum admissible [T_{2M}] se calcule en utilisant le facteur de service suivant : $T_{2M} = T_2 \times FS'$

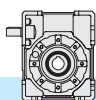

2.5 Datos técnicos

2.5 Technical data

2.5 Données techniques

130	$n_1 = 2800$				XA		XC - XF									
	i_n	n_2 [min ⁻¹]	Rd	P_{10}	T_{2M} [Nm]	P [kW]	T_2 [Nm]	P_1 [kW]	FS'	Input - IEC						
										XC		XF				
	B5/B14		B5		B14											
Kg 55.0	7.5	373	0.90	—	530	23	345	15	1.5	132	112 100	—	132	112 100	90	—
	10	280	0.89		549	18.1	455	15	1.2							
	15	187	0.87		636	14.3	490	11	1.3							
	20	140	0.86		733	12.5	645	11	1.1							
	25	112	0.85		710	9.8	667	9.2	1.1							
	30	93	0.81		729	8.8	622	7.5	1.2							
	40	70	0.80		819	7.5	819	7.5	1.0							
	50	56	0.78		758	5.7	732	5.5	1.0							
	65	43	0.75		648	3.9	499	3	1.3							
	80	35	0.73		637	3.2	598	3	1.1							
100	28	0.70	597	2.5	525	2.2	1.1									

130	$n_1 = 1400$				XA		XC - XF									
	i_n	n_2 [min ⁻¹]	Rd	P_{10}	T_{2M} [Nm]	P [kW]	T_2 [Nm]	P_1 [kW]	FS'	Input - IEC						
										XC		XF				
	B5/B14		B5		B14											
Kg 55.0	7.5	187	0.89	6.0	736	16.2	418	9.2	1.8	132	112 100	—	132	112 100	90	—
	10	140	0.88	5.5	756	12.6	552	9.2	1.4							
	15	93	0.85	4.4	855	9.8	803	9.2	1.1							
	20	70	0.84	4.1	974	8.5	860	7.5	1.1							
	25	56	0.83	3.9	920	6.5	778	5.5	1.2							
	30	47	0.79	3.2	947	5.9	883	5.5	1.1							
	40	35	0.76	2.8	1037	5.0	829	4	1.3							
	50	28	0.74	2.6	959	3.8	757	3	1.3							
	65	22	0.71	2.3	801	2.6	678	2.2	1.2							
	80	18	0.68	2.1	758	2.1	649	1.8	1.2							
100	14	0.64	1.8	699	1.6	655	1.5	1.1								

130	$n_1 = 900$				XA		XC - XF									
	i_n	n_2 [min ⁻¹]	Rd	P_{10}	T_{2M} [Nm]	P [kW]	T_2 [Nm]	P_1 [kW]	FS'	Input - IEC						
										XC		XF				
	B5/B14		B5		B14											
Kg 55.0	7.5	120	0.88	—	889	12.7	385	5.5	2.3	132	112 100	—	132	112 100	90	—
	10	90	0.87		905	9.8	508	5.5	1.8							
	15	60	0.84		1016	7.6	735	5.5	1.4							
	20	45	0.82		1149	6.6	957	5.5	1.2							
	25	36	0.81		1074	5.0	860	4	1.3							
	30	30	0.76		1113	4.6	968	4	1.2							
	40	23	0.73		1208	3.9	930	3	1.3							
	50	18	0.70		1077	2.9	817	2.2	1.3							
	65	14	0.67		924	2.0	832	1.8	1.1							
	80	11	0.64		869	1.6	815	1.5	1.1							
100	9	0.60	828	1.3	700	1.1	1.2									

130	$n_1 = 500$				XA		XC - XF									
	i_n	n_2 [min ⁻¹]	Rd	P_{10}	T_{2M} [Nm]	P [kW]	T_2 [Nm]	P_1 [kW]	FS'	Input - IEC						
										XC		XF				
	B5/B14		B5		B14											
Kg 55.0	7.5	67	0.86	—	1109	9.0	228	1.85	4.9	132	112 100	—	132	112 100	90	—
	10	50	0.84		1107	6.9	297	1.85	3.7							
	15	33	0.81		1230	5.3	429	1.85	2.9							
	20	25	0.79		1388	4.6	558	1.85	2.5							
	25	20	0.78		1266	3.4	689	1.85	1.8							
	30	17	0.72		1320	3.2	763	1.85	1.7							
	40	13	0.69		1423	2.7	975	1.85	1.5							
	50	10	0.66		1261	2.0	1166	1.85	1.1							
	65	8	0.63		1095	1.4	860	1.10	1.3							
	80	6	0.59		1082	1.2	992	1.10	1.1							
100	5	0.55	945	0.9	788	0.75	1.2									

* **ATENCIÓN:** el par máximo utilizable [T_{2M}] deberá calcularse con respecto al factor de servicio: $T_{2M} = T_2 \times FS'$

* **WARNING:** Maximum allowable torque [T_{2M}] must be calculated using the following service factor: $T_{2M} = T_2 \times FS'$

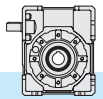

* **ATTENTION :** le couple maximum admissible [T_{2M}] se calcule en utilisant le facteur de service suivant : $T_{2M} = T_2 \times FS'$









2.6 **Momento de inercia** [Kg·cm²]
(referido al eje rápido de entrada)

2.6 **Moments of inertia** [Kg·cm²]
(referred to input shaft)

2.6 **Moments d'inertie** [Kg·cm²]
(se rapportant à l'arbre d'entrée)

X30	i_n	XA 	XC 		XF 	
			B5 - B14		B5 - B14	
			IEC 56	IEC 63	IEC 56	IEC 63
5	0.077	0.130	0.127	0.122	0.123	
7.5	0.058	0.112	0.109	0.102	0.103	
10	0.049	0.103	0.100	0.093	0.094	
15	0.042	0.097	0.094	0.087	0.087	
20	0.039	0.095	0.092	0.084	0.084	
25	0.038	0.094	0.091	0.083	0.083	
30	0.038	0.093	0.090	0.083	0.084	
40	0.037	0.093	0.090	0.082	0.082	
50	0.037	0.092	0.089	0.081	0.082	
65	0.024	0.079	-	0.069	0.069	
80	0.024	0.079	-	0.069	0.069	
100	0.024	0.078	-	0.069	0.069	

X40	i_n	XA 	XC 			XF 		
			B5 - B14			B5	B5 - B14	
			IEC 56	IEC 63	IEC 71	IEC 56	IEC 63	IEC 71
5	0.242	-	0.391	0.463	0.289	0.447	0.464	
7.5	0.170	-	0.321	0.356	0.217	0.375	0.391	
10	0.144	-	0.272	0.347	0.190	0.348	0.365	
15	0.125	-	0.266	0.340	0.171	0.329	0.346	
20	0.094	-	0.263	0.338	0.141	0.298	0.315	
25	0.091	-	0.262	0.337	0.137	0.295	0.312	
30	0.113	-	0.262	0.337	0.160	0.318	0.335	
40	0.087	-	0.261	-	0.134	0.292	0.309	
50	0.087	0.182	0.261	-	0.133	0.291	0.308	
65	0.069	0.182	0.261	-	0.116	0.274	0.290	
80	0.069	0.182	0.261	-	0.115	0.273	0.290	
100	0.068	0.182	0.261	-	0.115	0.273	0.290	



X50	i_n	XA 	XC 			XF 		
			B5 - B14			B5	B5 - B14	
			IEC 63	IEC 71	IEC 80	IEC 63	IEC 71	IEC 80
5	0.744	-	0.922	1.046	0.978	0.955	1.558	
7.5	0.499	-	0.684	0.935	0.733	0.750	1.313	
10	0.417	-	0.602	0.853	0.651	0.668	1.231	
15	0.358	-	0.543	0.794	0.593	0.609	1.173	
20	0.281	-	0.523	0.774	0.516	0.532	1.096	
25	0.272	-	0.513	0.764	0.506	0.523	1.086	
30	0.323	-	0.508	0.759	0.557	0.574	1.137	
40	0.262	0.315	0.503	-	0.496	0.513	1.076	
50	0.183	0.313	0.501	-	0.417	0.434	0.997	
65	0.136	0.311	0.499	-	0.370	0.387	0.950	
80	0.136	0.310	0.498	-	0.370	0.387	0.950	
100	0.135	0.309	0.498	-	0.370	0.386	0.950	







2.6 **Momento de inercia** [Kg·cm²]
(referido al eje rápido de entrada)

2.6 **Moments of inertia** [Kg·cm²]
(referred to input shaft)

2.6 **Moments d'inertie** [Kg·cm²]
(se rapportant à l'arbre d'entrée)

X63	i _n	XA 	XC 			XF 		
			B5 - B14			B5	B5 - B14	
			IEC 71	IEC 80	IEC 90	IEC 71	IEC 80	IEC 90
			5	1.853	-	2.431	2.671	2.632
7.5	1.363	-	1.949	2.269	2.142	2.276	3.354	
10	1.158	-	1.744	2.063	1.936	2.070	3.148	
15	1.011	-	1.597	1.916	1.789	1.924	3.001	
20	0.710	-	1.545	1.864	1.489	1.623	2.701	
25	0.679	-	1.514	1.833	1.458	1.592	2.670	
30	0.922	-	1.508	1.828	1.701	1.835	2.913	
40	0.660	0.966	1.495	-	1.439	1.573	2.651	
50	0.653	0.959	1.488	-	1.431	1.565	2.643	
65	0.552	0.955	1.484	-	1.330	1.465	2.542	
80	0.550	0.953	1.482	-	1.329	1.463	2.541	
100	0.549	0.952	1.481	-	1.327	1.462	2.539	

X75	i _n	XA 	XC 				XF 		
			B5 - B14				B5	B5 - B14	
			IEC 71	IEC 80	IEC 90	IEC 100-112	IEC 80	IEC 90	IEC 100-112
			7.5	2.970	-	-	3.712	4.462	5.138
10	2.492	-	-	3.234	3.984	4.661	4.588	6.359	
15	2.151	-	-	2.893	3.643	4.320	4.247	6.018	
20	1.567	-	-	2.774	3.523	3.735	3.662	5.433	
25	1.501	-	-	2.709	3.458	3.670	3.597	5.368	
30	1.946	1.615	1.575	2.689	3.438	4.115	4.042	5.813	
40	1.451	-	1.573	2.659	-	3.620	3.547	5.318	
50	1.435	-	1.570	2.642	-	3.603	3.531	5.302	
65	1.158	1.609	1.569	2.633	-	3.326	3.253	5.024	
80	1.153	1.605	1.565	2.629	-	3.322	3.249	5.020	
100	1.150	1.602	1.562	2.626	-	3.318	3.246	5.017	

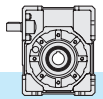

X89	i _n		XC 		
			B5 - B14		
			IEC 80	IEC 90	IEC 100-112
			7.5	-	6.898
10	-	5.875	6.648		
15	-	5.144	5.917		
20	-	3.398	5.661		
25	-	3.256	5.520		
30	-	3.215	5.479		
40	-	3.151	-		
50	-	3.115	-		
65	2.024	3.096	-		
80	2.014	3.087	-		
100	2.008	3.080	-		









2.6 **Momento de inercia** [Kg·cm²]
(referido al eje rápido de entrada)

2.6 **Moments of inertia** [Kg·cm²]
(referred to input shaft)

2.6 **Moments d'inertie** [Kg·cm²]
(se rapportant à l'arbre d'entrée)

X90	i_n	XA 	XC 			XF 		
			B5 - B14			B5	B5 - B14	
			IEC 80	IEC 90	IEC 100-112	IEC 80	IEC 90	IEC 100-112
7.5	6.167			6.898	7.671	8.335	8.263	10.033
10	5.143		-	5.875	6.648	7.312	7.239	9.010
15	4.413		-	5.144	5.917	6.581	6.508	8.279
20	2.653		-	3.398	5.661	4.821	4.749	6.519
25	2.511		-	3.256	5.520	4.680	4.607	6.378
30	3.974		-	3.215	5.479	6.142	6.070	7.841
40	2.406		-	3.151	-	4.574	4.502	6.273
50	2.371		-	3.115	-	4.539	4.467	6.237
65	1.672		2.024	3.096	-	3.841	3.768	5.539
80	1.663		2.014	3.087	-	3.831	3.759	5.530
100	1.656		2.008	3.080	-	3.825	3.752	5.523

X110	i_n	XA 	XC 			XF 			
			B5 - B14			B5			B5 - B14
			IEC 90	IEC 100-112	IEC 132	IEC 80	IEC 90	IEC 100-112	IEC 132
7.5	16.247		-	17.980	20.038	20.584	20.535	20.711	22.704
10	13.386		-	15.119	17.177	17.723	17.674	17.851	19.843
15	11.343		-	13.076	15.134	15.679	15.631	15.807	17.799
20	6.655		-	8.367	14.418	10.992	10.943	11.120	13.112
25	6.257		-	7.969	14.020	10.594	10.545	10.722	12.714
30	10.117		-	11.850	13.908	14.453	14.405	14.581	16.573
40	5.965		-	7.677	-	10.302	10.254	10.430	12.422
50	5.866		-	7.578	-	10.203	10.154	10.330	12.323
65	3.792		5.592	7.510	-	8.128	8.080	8.256	10.248
80	3.770		5.570	7.489	-	8.107	8.059	8.235	10.227
100	3.755		5.555	7.474	-	8.092	8.044	8.220	10.212

X130	i_n	XA 	XC 			XF 		
			B5 - B14			B5		
			IEC 90	IEC 100-112	IEC 132	IEC 90	IEC 100-112	IEC 132
7.5	42.80		-	40.70	42.78	48.92	49.22	50.01
10	35.06		-	32.96	35.04	41.18	41.48	42.27
15	29.53		-	27.43	29.51	35.66	35.96	36.74
20	18.95		-	16.68	27.58	25.07	25.37	26.16
25	17.80		-	15.52	26.42	23.92	24.22	25.00
30	26.22		-	24.12	26.20	32.34	32.64	33.42
40	17.09		-	14.81	25.71	23.21	23.51	24.29
50	16.80		-	12.57	-	22.92	23.22	24.00
65	12.53		10.46	14.35	-	18.66	18.96	19.74
80	12.48		10.41	14.30	-	18.60	18.90	19.68
100	12.44		10.37	14.26	-	18.56	18.86	19.65

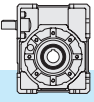

2.7 Tamaño

2.7 Dimensions

2.7 Dimensions

XA

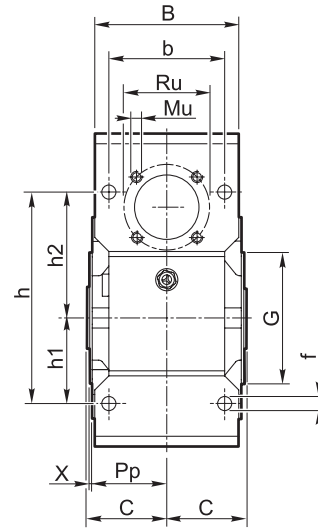
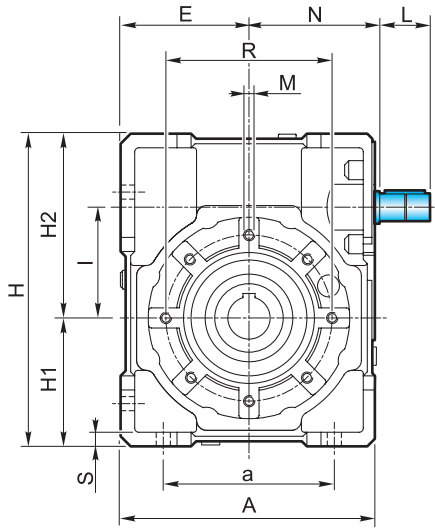

XF

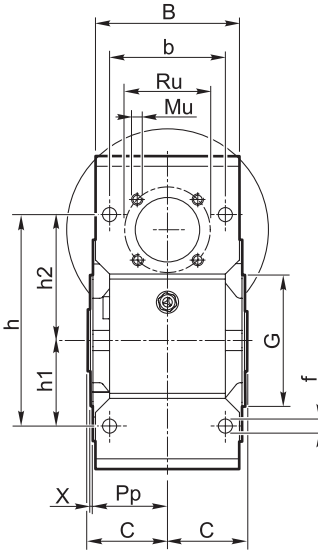
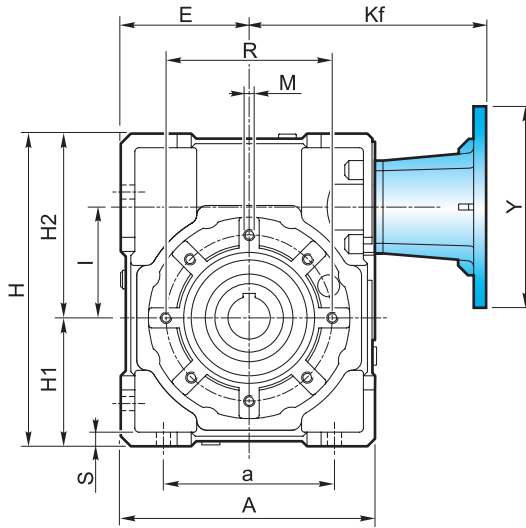

XC

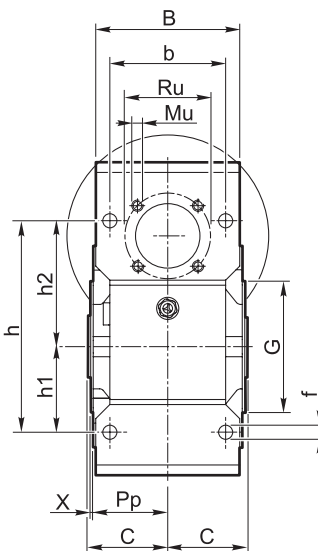
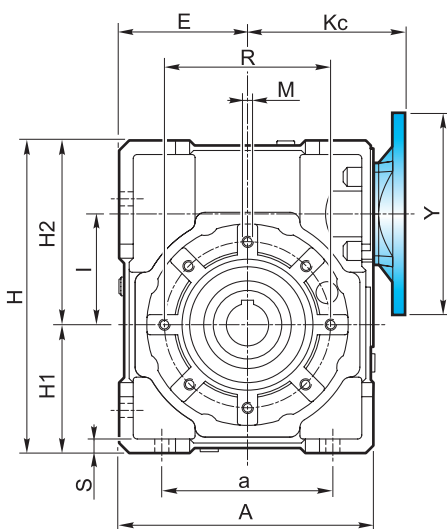

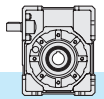

2.7 Tamaño

2.7 Dimensions

2.7 Dimensions

Brida pendular / Shaft-mounted flange / Bride pendulaire

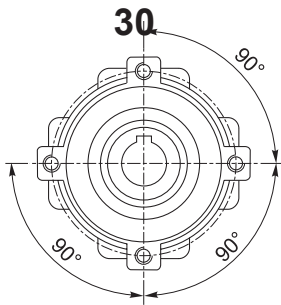

4 Agujeros / Holes / Trous

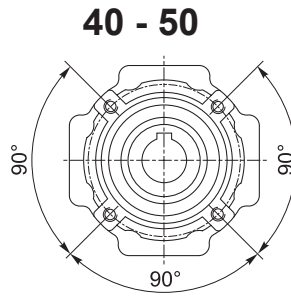

4 Agujeros / Holes / Trous

63 - 75 - 89 - 90 - 110 - 130

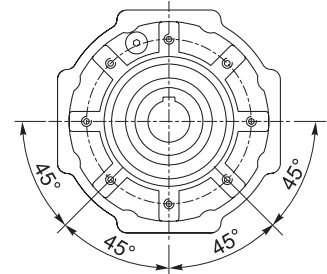

8 Agujeros / Holes / Trous

Eje juego de consulta
Output hollow shaft
Arbre de sortie creux

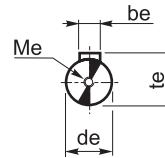
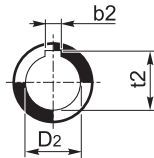

Eje de entrada
Input shaft
Arbre d'entrée

X	A	a	B	b	b _e	b ₂	C	d _e j6	D ₂ H8	E	f	G h8	H	H ₁	H ₂	h	h ₁	h ₂		
30	80	54	56	44	3	5	—	31.5	9	14	—	40	6.5	55	97	40	57	71	27	44
40	105	70	71	60	4	6	6	39	11	18	19	50	6.5	60	125	50	75	90	35	55
50	125	80	85	70	5	8	8	46	14	25	24	60	8.5	70	150	60	90	104	40	64
63	147	100	103	85	6	8	—	56	19	25	—	72	9	80	182	72	110	130	50	80
75	176	120	112	90	8	8	8	60	24	28	30	86	11	95	219.5	86	133.5	153	60	93
89*	203	140	130	100	—	10	—	70	—	35	—	103	13	110	248.5	103	145.5	172	70	102
90	203	140	130	100	8	10	—	70	24	35	—	103	13	110	248.5	103	145.5	172	70	102
110	252.5	170	143	115	8	12	—	77.5	28	42	—	127.5	14	130	310.5	127.5	183	210	85	125
130	292.5	200	155	120	10	14	14	85	38	45	48	147.5	15	180	355	147.5	207.5	240	100	140

X	I	K _c	K _f	L	M	M _e	M _u	N	P _p	R	R _u	S	t _e	t ₂	X	
30	31.5	57	consulte pàg see page voir page	15	M6x8	M4x10	M5x7.5	44.5	29	65	35.4	5.5	10.2	16.3	—	1.5
40	40	75		20	M6x10	M4x12	M5x10	57.5	36.5	75	42.4	6	12.5	20.8	21.8	1.5
50	50	82		25	M8x10	M5x13	M6x10	67.5	43.5	85	53.7	7	16	28.3	27.3	1.5
63	63	95		30	M8x14	M8x20	M6x12	77.5	53	95	60.8	8	21.5	28.3	—	2
75	75	112 - 110 ⁽¹⁾		40	M8x14	M8x20	M8x12	95	57	115	70.7	10	27	31.3	33.3	2
89*	90	122		—	M10x18	—	M8x14	—	67	130	70.7	12	—	38.3	—	2
90	90	122		40	M10x18	M8x20	M8x14	105	67	130	70.7	12	27	38.3	—	2
110	110	153		50	M10x18	M8x20	M10x18	130	74	165	85.0	14	31	45.3	—	2.5
130	130	173		70	M12x20	M10x25	M10x16	152	81	215	104	15	41	48.8	51.8	3

*: 89 solo con entrada tipo C

*: 89 only with input type C

*: 89 uniquement avec le type d'entrée C

(1): Solo para PAM 71B14 / Only for PAM 71B14 / juste pour PAM 71B14



2.7 **Tamaño**

2.7 **Dimensions**

2.7 **Dimensions**

Brida de salida / *Output flange* / Bride de sortie

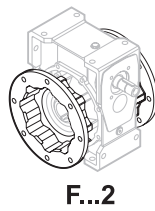
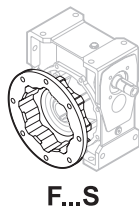
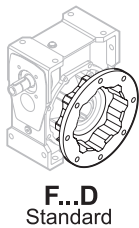
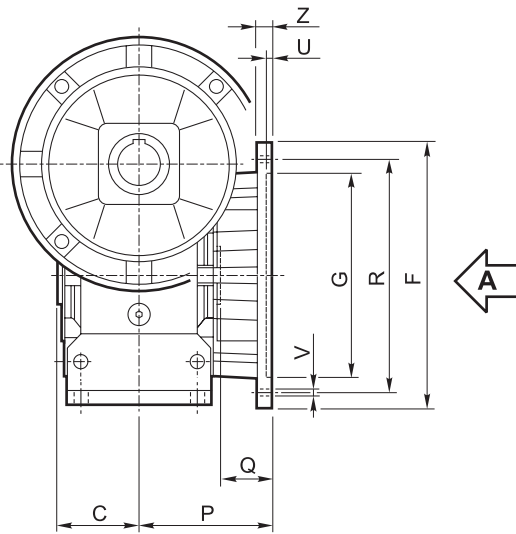

Vista de A / *View from A* / Vue depuis A

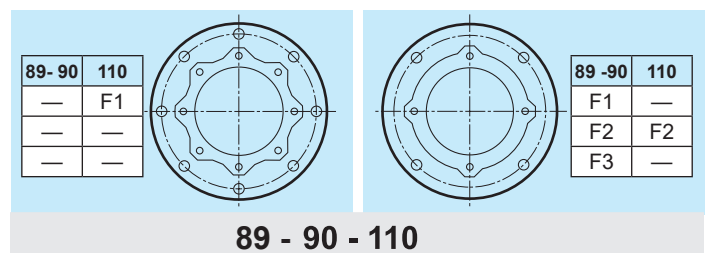
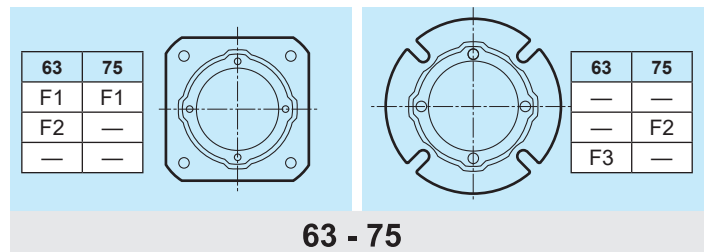
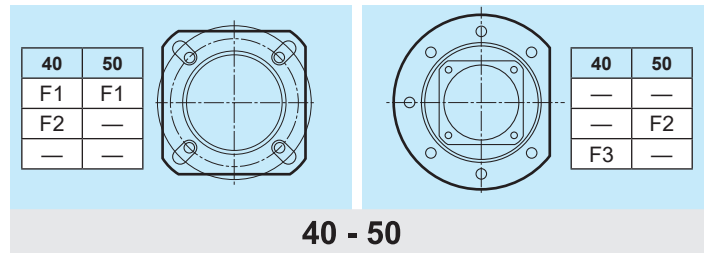
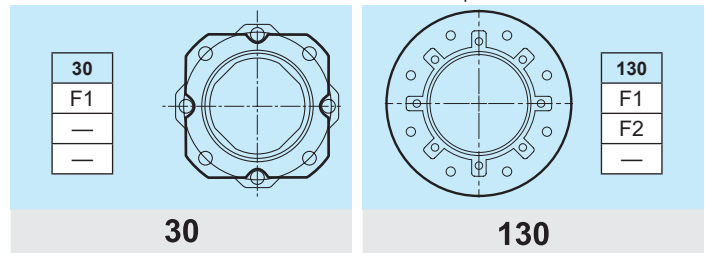

Tipo Type Typ	C	F		G H8	P	Q	R	U	V			Z
											Ø	
30	F1	31.5		66	50	54.5	23	68	4	n° 4	6.5	6
	F2											
	F3											
40	F1	39		85	60	67	28	75-90	4	n° 4	9	8
	F2			85	60	97	58	75-90	4	n° 4	9	8
	F3			140	95	80	41	115	5	n° 7	9	10
50	F1	46		94	70	90	44	85-100	5	n° 4	11	10
	F2			160	110	89	43	130	5	n° 7	11	11
	F3											
63	F1	56		142	115	82	26	150	5	n° 4	11	11
	F2			142	115	112	56	150	5	n° 4	11	11
	F3			160	110	80.5	24.5	130	5	n° 4	11	12
75	F1	60		160	130	111	51	165	5	n° 4	13	12
	F2			160	110	90	30	130	6	n° 4	11	13
	F3											
89 90	F1	70		200	152	111	41	175	5	n° 4	13	12
	F2			200	152	151	81	175	5	n° 4	13	13
	F3			200	130	110	40	165	6	n° 4	11	11
110	F1	77.5		260	170	131	53.5	230	6	n° 8	13	15
	F2			250	180	150	72.5	215	5	n° 4	15	16
	F3											
130	F1	85		320	180	140	55	255	7	n° 8 *	16	16
	F2			300	230			265				
	F3											

* Agujero girado 22.5°

* Drilling turned of 22.5°

* Perçage tourné de 22,5°

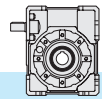

2.7 Tamaño

2.7 Dimensions

2.7 Dimensions

Brida entrada / Input flange / Bride d'entrée

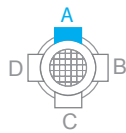

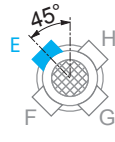

PM = 1

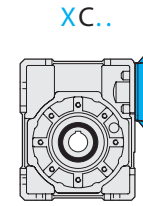
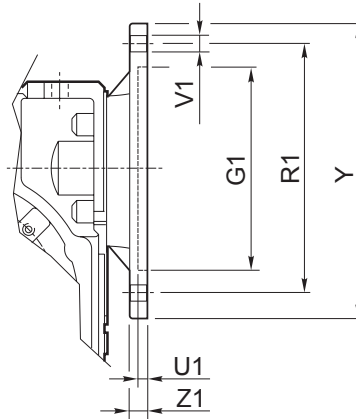

PM = 2



XC	IEC	G ₁	PM		R ₁	U ₁	V ₁			Y	Z ₁	Diámetro orificios PAM / Holes diameter IEC / Diamètres trous PAM											
			1	2			Ø						5	7.5	10	15	20	25	30	40	50	65	80
30	56 B5	80	•	•	100	4	7	8			8	9	9	9	9	9	9	9	9	9	9	9	9
	56 B14	50	•	•	65	3.5	6	8		80	8	9	9	9	9	9	9	9	9	9	9	9	9
	63 B5	95	•	•	115	4	9	8		140	8	11	11	11	11	11	11	11	11	11	/	/	/
	63 B14	60	•	•	75	4	6	8		90	8	11	11	11	11	11	11	11	11	11	/	/	/
40	56 B5	80	•	•	100	4	7	8		120	9	/	/	/	/	/	/	/	/	9	9	9	9
	56 B14	50	•	•	65	3.5	6		4	80	8	/	/	/	/	/	/	/	/	9	9	9	9
	63 B5	95	•	•	115	4	9	8		140	9	11	11	11	11	11	11	11	11	11	11	11	11
	63 B14	60	•	•	75	3.5	6		4	90	8	11	11	11	11	11	11	11	11	11	11	11	11
	71 B5	110	•	•	130	4.5	9	8		160	10	14	14	14	14	14	14	14	14	/	/	/	/
	71 B14	70	•	•	85	3.5	7	8		105	8	14	14	14	14	14	14	14	14	/	/	/	/
50	63 B5	95	•	•	115	4	9	8		140	9	/	/	/	/	/	/	/	11	11	11	11	11
	63 B14	60	•	•	75	3.5	6		4	90	8	/	/	/	/	/	/	/	11	11	11	11	11
	71 B5	110	•	•	130	4.5	9	8		160	10	14	14	14	14	14	14	14	14	14	14	14	14
	71 B14	70	•	•	85	3.5	7		4	105	8	14	14	14	14	14	14	14	14	14	14	14	14
	80 B5	130	•	•	165	4.5	11	8		200	10	19	19	19	19	19	19	19	19	/	/	/	/
	80 B14	80	•	•	100	4	7	8		120	10	19	19	19	19	19	19	19	19	/	/	/	/
63	71 B5	110	•	•	130	4.5	9	8		160	10	/	/	/	/	/	/	/	14	14	14	14	14
	71 B14	70	•	•	85	3.5	7		4	105	10	/	/	/	/	/	/	/	14	14	14	14	14
	80 B5	130	•	•	165	4.5	11	8		200	10	19	19	19	19	19	19	19	19	19	19	19	19
	80 B14	80	•	•	100	4	7		4	120	10	19	19	19	19	19	19	19	19	19	19	19	19
	90 B5	130	•	•	165	4.5	11	8		200	10	24	24	24	24	24	24	24	24	/	/	/	/
	90 B14	95	•	•	115	4	8.5	8		140	10	24	24	24	24	24	24	24	24	/	/	/	/
75	71 B5	110	•	•	130	4.5	9	8		160	10	/	/	/	/	/	/	14	/	/	14	14	14
	71 B14	70	•	•	85	3.5	7		4	105	11	/	/	/	/	/	/	14	/	/	14	14	14
	80 B5	130	•	•	165	4.5	11	8		200	10	/	/	/	/	/	/	19	19	19	19	19	19
	80 B14	80	•	•	100	4	7		4	120	11	/	/	/	/	/	/	19	19	19	19	19	19
	90 B5	130	•	•	165	4.5	11	8		200	10	/	24	24	24	24	24	24	24	24	24	24	24
	90 B14	95	•	•	115	4	9		4	140	11	/	24	24	24	24	24	24	24	24	24	24	24
	100/112 B5	180	•	•	215	5	14	8		250	13	/	28	28	28	28	28	28	28	/	/	/	/
100/112 B14	110	•	•	130	4.5	9	8		160	11	/	28	28	28	28	28	28	28	/	/	/	/	
89	80 B5	130	•	•	165	4.5	11	8		200	10	/	/	/	/	/	/	/	/	/	19	19	19
	80 B14	80	•	•	100	4	7		4	120	11	/	/	/	/	/	/	/	/	/	19	19	19
	90 B5	130	•	•	165	4.5	11	8		200	10	/	24	24	24	24	24	24	24	24	24	24	24
	90 B14	95	•	•	115	4	9		4	140	11	/	24	24	24	24	24	24	24	24	24	24	24
	100/112 B5	180	•	•	215	5	14	8		250	13	/	28	28	28	28	28	28	28	/	/	/	/
	100/112 B14	110	•	•	130	4.5	9	8		160	11	/	28	28	28	28	28	28	28	/	/	/	/
110	90 B5	130	•	•	165	5	11	4		200	12	/	/	/	/	/	/	/	24	/	24	24	24
	90 B14	95	•	•	115	5	9		4	140	12	/	/	/	/	/	/	/	24	/	24	24	24
	100/112 B5	180	•	•	215	5	14	4		250	14	/	28	28	28	28	28	28	28	28	28	28	28
	100/112 B14	110	•	•	130	5	9		4	160	12	/	28	28	28	28	28	28	28	28	28	28	28
	132 B5	230	•	•	265	5	14	4		300	14	/	38	38	38	38	38	38	38	/	/	/	/
	132 B14	130	•	•	165	5	11	4		200	12	/	38	38	38	38	38	38	38	/	/	/	/
130	90 B5	130	•	•	165	5	11	4		200	12	/	/	/	/	/	/	/	/	/	24	24	24
	90 B14	95	•	•	115	5	9		4	140	12	/	/	/	/	/	/	/	/	/	24	24	24
	100/112 B5	180	•	•	215	5	14	4		250	14	/	28	28	28	28	28	28	28	28	28	28	28
	100/112 B14	110	•	•	130	5	9		4	160	12	/	28	28	28	28	28	28	28	28	28	28	28
	132 B5	230	•	•	265	5	14	4		300	14	/	38	38	38	38	38	38	38	38	/	/	/
	132 B14	130	•	•	165	5	11	4		200	12	/	38	38	38	38	38	38	38	/	/	/	/

N.B.: El montaje STD de P_M=2 solo cuando no es posible el montaje STD de P_M=1.
 N.B.: Es posible también realizar todas las composiciones híbridas obtenibles de las bridas existentes.

N.B.: STD mounting of P_M=2 only if STD mounting of P_M=1 is not possible.
 N.B.: it is possible to create hybrid combinations with the existing flanges.

N.B.: Montage STD P_M=2 seulement lorsque le montage STD P_M=1 n'est pas possible.
 N.B.: Il est possible de réaliser des compositions hybrides à partir des brides existantes.

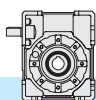

2.7 Tamaño

2.7 Dimensions

2.7 Dimensions

Brida entrada / Input flange / Bride d'entrée

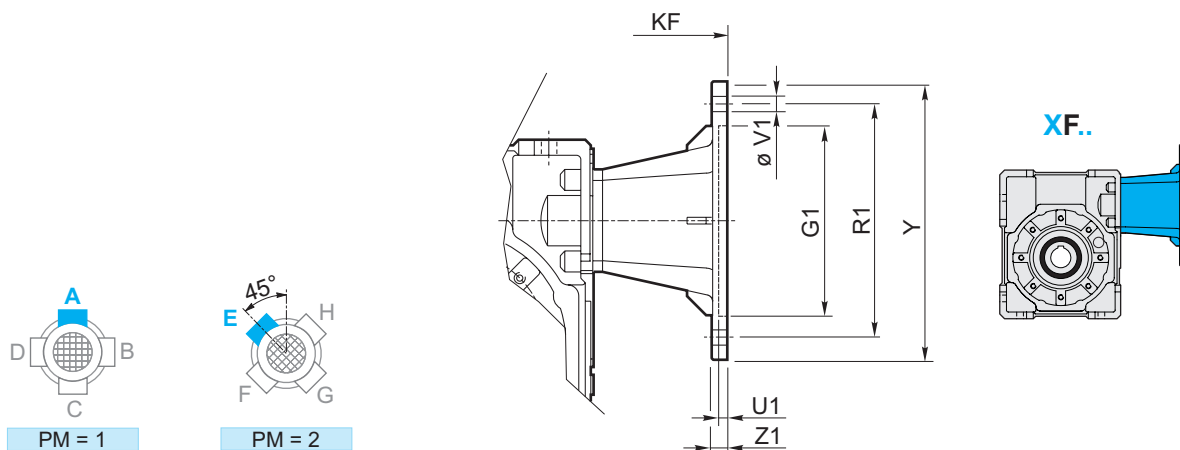

XF	IEC	PM		G ₁	K _F	V ₁						Y	Z ₁
		1	2			R ₁	U ₁	Ø					
30	56 B5	•	•	80	82.5	100	3.5	7		8		120	8
	56 B14		•	50	82.5	65	3.5	6			4	80	8
	63 B5	•	•	95	85.5	115	4	9		8		140	10
	63 B14	•	•	60	85.5	75	3.5	6		8		90	8
40	56 B5	•	•	80	101.5	100	3.5	7		8		120	8
	63 B5	•	•	95	104.5	115	4	9		8		140	10
	63 B14	•	•	60	104.5	75	3.5	6		8		90	8
	71 B5	•	•	110	111.5	130	4.5	9		8		160	10
	71 B14	•	•	70	111.5	85	4	7		8		105	10
50	63 B5	•	•	95	119.5	115	4	9		8		140	10
	71 B5	•	•	110	126.5	130	4.5	9		8		160	10
	71 B14		•	70	126.5	85	3.5	7			4	105	10
	80 B5	•	•	130	136.5	165	4.5	11		8		200	10
	80 B14	•	•	80	136.5	100	4	7		8		120	10
63	71 B5	•	•	110	141.5	130	4.5	9		8		160	10
	80/90 B5	•	•	130	161.5	165	4.5	11		8		200	10
	80 B14	•	•	80	151.5	100	4	7		8		120	10
	90 B14	•	•	95	161.5	115	4	9		8		140	10
75	80/90 B5	•	•	130	190	165	4.5	11		8		200	10
	90 B14		•	95	190	115	4	9			4	140	10
	100/112 B5	•	•	180	200	215	5	14		8		250	14
	100/112 B14	•	•	110	200	130	4.5	9		8		160	10
90	80/90 B5	•	•	130	200	165	4.5	11		8		200	10
	90 B14		•	95	200	115	4	9			4	140	10
	100/112 B5	•	•	180	210	215	5	14		8		250	14
	100/112 B14	•	•	110	210	130	4.5	9		8		160	10
110	80/90 B5	•		130	235	165	4.5	11	4			200	12
	100/112 B5	•		180	245	215	5	14	4			250	14
	132 B5	•		230	266	265	5	14	4			300	16
	132 B14	•		130	266	165	4.5	11	4			200	12
130	90 B5	•		130	281	165	4.5	M10	4			200	12
	100/112 B5	•		180	289	215	5	13	4			250	16
	132 B5	•		230	310	265	5	13	4			300	20

N.B.: El montaje STD de P_M=2 solo cuando no es posible el montaje STD P_M=1.

N.B.: STD mounting of P_M=2 only if STD mounting of P_M=1 is not possible.

N.B.: Montage STD P_M=2 seulement lorsque le montage STD P_M=1 n'est pas possible.

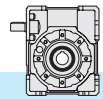

2.8 Entrada suplementaria
(tornillos con doble salida)

2.8 Additional input
(double extended shaft)

2.8 Entrée supplémentaire
(arbre à double entrée)

S.e.A.

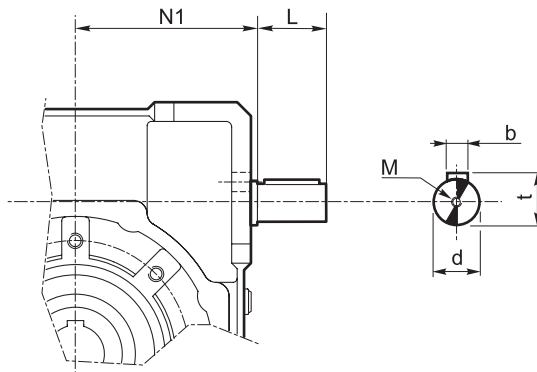

X	d j6	L	M	N1	b	t
30	9	15	M4x10	42.5	3	10.2
40	11	20	M4x12	52.5	4	12.5
50	14	25	M5x13	62.5	5	16
63	19	30	M8x20	74.5	6	21.5
75	24	40	M8x20	91	8	27
89 - 90	24	40	M8x20	108	8	27
110	28	50	M8x20	132.5	8	31
130	38	70	M10x25	152	10	41

2.9 Limitador de par
agujero pasante

2.9 Torque limiter with through
hollow shaft

2.9 Limiteur de couple creux continu

El limitador de par se aconseja en todas las aplicaciones donde requieran una limitación en el par transmisible para la protección de la instalación y/o preservar el reductor de sobrecargas o golpes inesperados.

Es un dispositivo dotado de eje con agujero pasante, su funcionamiento en fricción, integrado en el reductor y ocupa un espacio limitado.

Realizados para trabajar en baño de aceite, el dispositivo resulta fiable en el tiempo y es exente a usar si no es mantenido en condiciones prolongadas de deslizamiento (condiciones que se verifican cuando el par tiene valores superiores a los del calibrado).

El calibrado es fácilmente regulable desde el externo, a través de la sujeción de una abrazadera autoblocante que comprime los cuatro resortes a taza dispuestos entre ellos en serie.

El dispositivo no permite:

- El uso de cojinetes de rodillos cónicos en salida.
- funcionamiento prolongando en condiciones de deslizamiento

En la siguiente tabla se detallan los valores de los pares de deslizamiento M_{2S} en función del n° de giros de la abrazadera. Los valores para calibrar tienen tolerancia del $\pm 10\%$ con referencia a la condición estática.

En condiciones dinámicas se note que el par de deslizamiento asume valores distintos según el tipo y/o modalidad en el cual se verifica la sobrecarga: con valores mayores en caso de cargas uniformemente creciente, con respecto a pesos menores, se debe a picos imprevistos de cargas.

NOTA: Cuando se superan los valores de calibrado se obtiene el deslizamiento.

El coeficiente de fricción entre la superficie de contacto del estático deviene dinámico y el par transmitido baja aproximadamente un 30%.

De hecho es oportuno anticipar un stop para así poder iniciar con los valores de base del calibrado.

The use of a torque limiter is advised when the application requires the limitation of the transmissible torque to safeguard the plant and/or to prevent from unexpected and undesired overloads or shocks which might damage the gearbox.

The torque limiter is a device equipped with through hollow shaft and a friction clutch. It is integrated with the gearbox, therefore the space requirement is limited.

Designed to work in oil bath, the device is reliable over time and is not subject to wear unless kept under conditions of prolonged slipping (it occurs when the torque values are higher than the calibration values).

Calibration can be easily adjusted from outside by tightening the self-locking ring nut which causes the compression of the 4 Belleville washers arranged in series.

The device does not go together with:

- the use of tapered roller bearings at output
- Prolonged operation under slipping conditions.

The following table shows the values of M_{2S} slipping torques depending on the number of revolutions of the ring nut.

Calibration values feature a $\pm 10\%$ tolerance and refer to static conditions.

Under dynamic conditions, the values of the slipping torque differ depending to the type of overload: the values are higher if the load increase is uniform, the values are lower if sudden load peaks occur.

NOTE: Slipping occurs when the setting values are exceeded.

The friction coefficient between the contact surfaces from static becomes dynamic and the transmitted torque is approx. 30% lower.

It is advisable to have a stop first in order to have a restart based on the initial setting value.

Le limiteur de couple est conseillé pour toutes les applications qui nécessitent une limitation sur le couple transmissible pour protéger la machine et/ou préserver le réducteur en évitant les surcharges ou les chocs.

Le limiteur fonctionne à friction et il est doté d'un arbre creux continu. Il est, de plus, intégré au réducteur, ce qui offre un encombrement limité.

Conçu pour fonctionner en bain d'huile, le dispositif est fiable sur la durée et il ne s'use pas, sauf en cas de glissement prolongé (condition qui se vérifie lorsque le couple présente des valeurs supérieures à celles du calibrage).

Le calibrage se fait facilement depuis l'extérieur en serrant une frette autobloquante qui comprime les 4 rondelles Belleville disposées en série.

Le dispositif ne permet pas :

- l'utilisation de roulements à rouleaux coniques à la sortie.
- le fonctionnement prolongé en condition de glissement.

Dans le tableau ci-dessous sont reportés les valeurs des couples de glissement M_{2S} en fonction du nombre de tours de la frette.

Les valeurs de calibrage ont une tolérance de $\pm 10\%$ et se réfèrent à une condition statique.

Dans des conditions dynamiques, les valeurs du couple de glissement diffèrent en fonction du type de surcharge: les valeurs sont plus élevées si la charge augmente de manière continue, mais elles sont plus basses si l'on a une augmentation soudaine de la charge.

REMARQUE : il y a glissement lorsque la valeur de calibrage est dépassée.

Le coefficient de frottement entre les surfaces en contact passe de statique à dynamique et le couple transmis chute d'environ 30%.

Il est donc recommandé de s'arrêter afin de pouvoir repartir sur la base du calibrage initial.



Es importante notar que el par de deslizamiento no es siempre el mismo durante la vida del limitador.

De hecho tiende a disminuir en relación al número y a su durabilidad de los deslizamientos, que rodando las superficies de contacto, aumenta el rendimiento.

Entonces es aconsejable verificar periódicamente, sobretodo durante la fase de rodaje, el calibre del dispositivo.

Allí donde se exige un error mayor de contenido en la calibración, es necesario probar el par transmisible en la instalación.

El dispositivo se entrega calibrado al par referido en el catálogo como T_{2M} excepto distintas indicaciones que se expresan ordenadamente en fase.

It is important to note that the slipping torque is not the same for the entire life of the torque limiter. It usually decreases in connection with the number and the duration of slippings, this is due to the surface of the torque limiter becoming more engaged, therefore increasing the efficiency. For this reason it is advisable to check the calibration of the device at regular intervals, specially during the running-in period. Should a smaller calibration error be required, it is necessary to test the transmissible torque on the plant.

The torque limiter is supplied already calibrated at the torque value T_{2M} , unless otherwise specified in the order.

Il est important de remarquer que le couple de glissement change au fur et à mesure de l'utilisation du limiteur.

Il a en effet tendance à diminuer par rapport au nombre et à la durée des glissements qui, en rodant les surfaces de contact, en augmentent le rendement.

Il est donc conseillé de régulièrement vérifier, surtout pendant la phase de rodage, le calibrage du dispositif.

Si une erreur minime est réclamée pour le calibrage, il est nécessaire de tester le couple transmissible sur la machine.

Le dispositif est livré calibré sur le couple reporté T_{2M} dans le catalogue, sauf suite à une demande spécifique faite au moment de la commande.

X	N°. giros de la abrazadera de regulación / N°. revolutions of ring nut / N°. tours de l'anneau de réglage															
	3/4	1	1 1/4	1 1/2	1 3/4	2	2 1/4	2 1/2	2 3/4	3	3 1/4	3 1/2	3 3/4	4	4 1/4	4 1/2
	M_{2S} [Nm]															
30		15	18	22	27	32										
40	23	30	35	40	45	50	60									
50		45	60	70	80	90	100	110								
63			80	90	100	110	120	130	140	150	160	170	180	190	200	
75		140	160	180	200	220	240	260	280	300						
89 - 90						230	280	310	330	350	380	410	435	460	490	510
110		420	500	560	670	730	810	910								
130																

Disposición de los resortes
Washers' arrangement
Position des rondelles

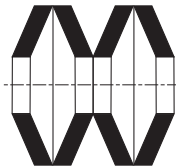

IN SERIE (min. par, max. sensibilidad)
SERIES (min. torque, max sensitivity)
EN SÉRIE (min. couple, max. sensibilité)

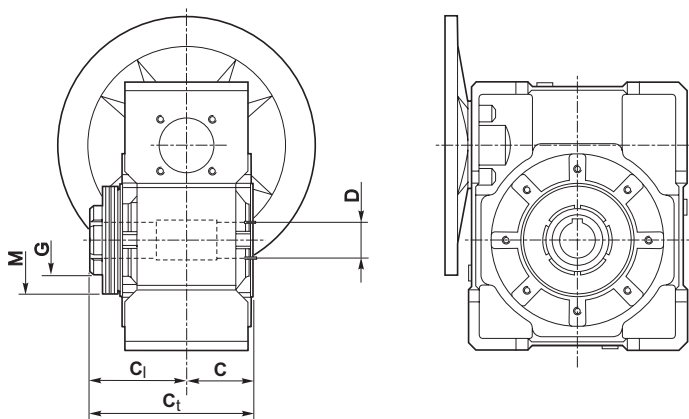

X	C	C _i	C _t	D _{H8}	M	G
30	31.5	55.5	87	14	50x25.4x1.25	M25x1.5
40	39	65	104	18 (19)	56x30.5x1.5	M30x1.5
50	46	76	122	25 (24)	63x40.5x1.8	M40x1.5
63	56	91	147	25	71x40.5x2	M40x1.5
75	60	100	160	28 (30)	90x50.5x2.5	M50x1.5
89 - 90	70	109	179	35 (32)	100x51x2.7	M50x1.5
110	77.5	127.5	205	42	125x61x4	M60x2.0
130						

() A pedido / On request / Sur demande

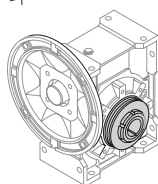

LD

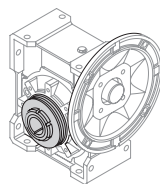

LS

La versión con limitador no se incluyen los ejes lentos.

The version with torque limiter is supplied without output shafts.

Les arbres lents ne sont pas fournis dans la version avec limiteur.

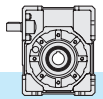

2.10 Accesorios

2.10 Accessories

2.10 Accessoires

Eje lento

Output shaft

Arbre lent

Eje lento standard
Single output shaft
Arbre lent simple

Eje lento doble
Double output shaft
Arbre lent double

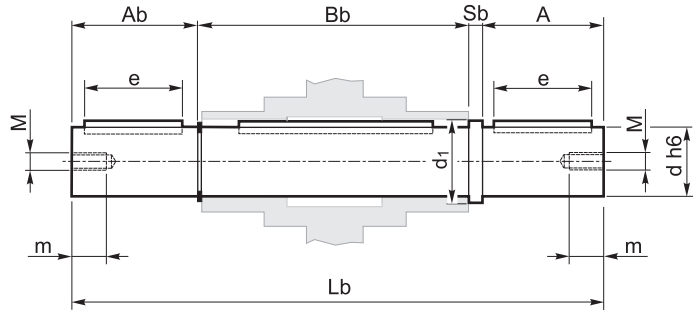
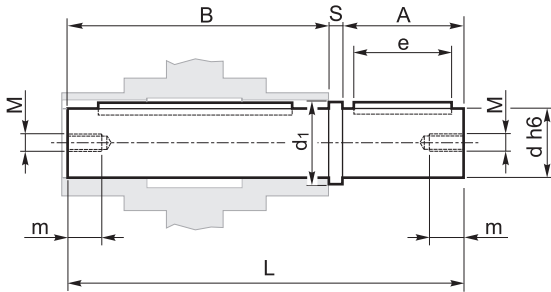

X	A	B	d _{h6}		d ₁	e	L	M	m	S
30	30	62	14		18.5	20	94.5	M6	16	2.5
40	40	77	18	19	23.5	30	120	M6	16	3
50	50	90	25	24	31.5	40	143.5	M8	22	3.5
63	50	111	25		31.5	40	165	M8	22	4
75	60	119	28	30	34.5	50	183	M8	22	4
89 - 90	80	139	35		41.5	60	224	M10	28	5
110	80	154.5	42		49.5	60	242.5	M10	28	8
130	80	168	45		54.5	70	253	M16	36	5

A	A _b	B _b	d _{h6}	d ₁	e	L _b	S _b
30	29	64	14	18.5	20	126	2.5
40	39	79	18	23.5	30	161	3
50	49	93	25	31.5	40	195.5	3.5
50	49	113	25	31.5	40	216	4
60	59	121	28	34.5	50	244	4
80	78.5	141.5	35	41.5	60	305	5
80	77.5	157	42	49.5	60	322.5	8
80	78	172	45	54.5	70	335	5

Brazo de reacción

Torque arm

Bras de réaction

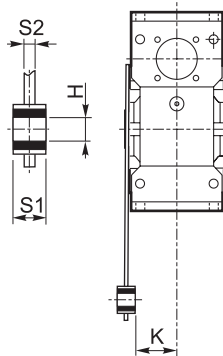
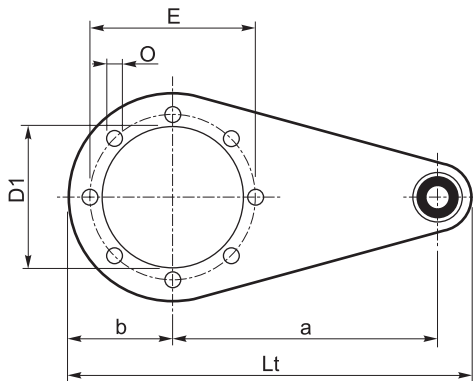

X	a	b	D ₁	E	H	K	L _t	O	S ₁	S ₂
30	85	37.5	55	65	8	24	141.5	7	14	4
40	100	45	60	75	10	31.5	167	7	14	4
50	100	50	70	85	10	39	172	9	14	5
63	150	55	80	95	10	49	227	9	14	6
75	200	70	95	115	20	47.5	302	9	25	6
89 - 90	200	80	110	130	20	57.5	312	11	25	6
110	250	100	130	165	25	62	390	11	30	6
130	250	125	180	215	25	69	415	13	30	6

Kit de protección:

Protection Kit:

Kit de protection

Eje hueco / Hollow shaft / Arbre creux

Limitador de par / Torque limiter / Limiteur de couple

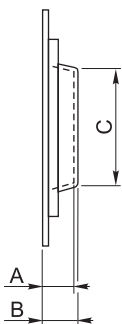

X	A	B	C
30	12	13	39
40	14	15.5	44.5
50	15	16.5	54
63	17	19	60
75	17.5	20	70
89 - 90	21.5	24	80
110	22	25	96
130	22	25	130

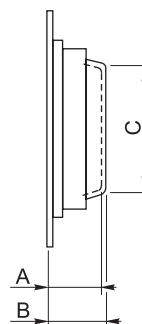

X	A	B	C
30	36	37	36
40	40	41.5	44
50	47	48.5	53
63	52	54	55
75	58	60	68
89 - 90	60.5	63	70
110	72	75	85
130			

Opciones disponibles:

Available options:

Options disponibles :

Cojinetes de rodillos conicos engranaje

Tapered roller bearing on wormgear

Roulements coniques sur la roue