

# MONO

MOTORI ELETTRICI MONOFASE  
MOTEURS ÉLECTRIQUES MONOPHASÉS



# DELPHI

MOTORI ELETTRICI TRIFASE  
MOTEURS ÉLECTRIQUES TRIPHASÉS



manuale tecnico  
manuel technique

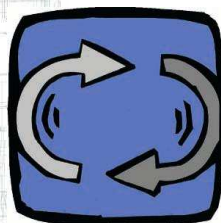
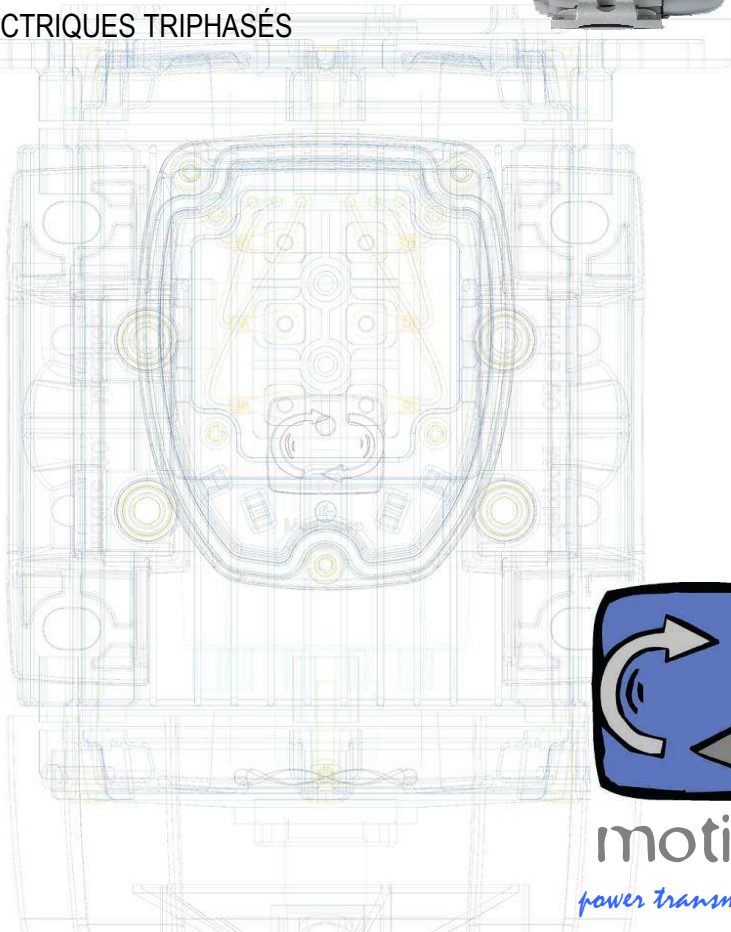

**motive**  
*power transmission*



## **indice**

### **Titolo**

**Caratteristiche tecniche**

**Condizioni di funzionamento**

**Protezioni elettriche e termiche**

**Tettuccio parapigioggia**

**Schemi di collegamento**

**Motori autofrenanti serie Delphi AT..**

**Motori servoventilati - serie SV**

**Trasporto, conservazione, uso e manutenzione**

**Lubrificazione cuscinetti**

**Lista ricambi**

**Marcatura CE**

**Dichiarazione di conformità**

## **Sommaire**

### **titre**

**Caractéristiques techniques**

**Conditions de fonctionnement**

**Schémas de couplage**

**Protections**

**toit de protection**

**motors frein AT..**

**Servoventilations**

**Transport, conservation, utilise et maintenance**

**Lubrification des roulements**

**Liste des composants**

**Marquage CE**

**Conformity Declaration**



## Caratteristiche tecniche

I motori Motive sono realizzati secondo le norme internazionali di unificazione ed adatti ad un uso universale; ogni dimensione, per tutte le forme costruttive, è stata dedotta facendo riferimento alle tabelle relative alla norma IEC 72-1;

Le forme costruttive realizzate, secondo IEC 34-7, sono B3, B5, B14, B3/B5, B3/B14, B14B

**I motori asincroni trifase Motive sono di tipo chiuso, con ventilazione esterna.**

**La carcassa, fino al tipo 132 incluso, è ottenuta da pressofusione di lega d'alluminio, dal 160 in poi da fusioni in ghisa.**



**Il rotore è a gabbia di scoiattolo e viene equilibrato dinamicamente secondo le norme IEC 34-14 e ISO 8821.**

**Tutti i motori sono multitemperatura, e multifrequenza 50/60Hz secondo i valori esposti a destra  
 classe di isolamento F, servizio continuo S1\*, protezione IP55.  
 Il rendimento è classificato in targa IE2/IE3 come da norma IE 60034-30**

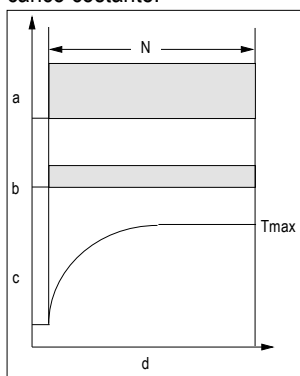
\*S1 - Servizio continuo: funzionamento a carico costante.



- a= carico
- b= perdite elettriche
- c= temperatura
- d= tempo
- N= tempo funzionamento a carico costante
- Tmax= temperatura massima raggiunta

		Volts		
size	Hz			
		56-132	50	230
220	380			(Pn=100%)
240	415			(Pn=100%)
60	260		440	(Pn=110%)
	220		380	(Pn=100%)
	265		460	(Pn=115%)
		280	480	(Pn=120%)

132-400	50	400	690	(Pn=100%)
		380	660	(Pn=100%)
		415	720	(Pn=100%)
	60	440	760	(Pn=110%)
		380	660	(Pn=100%)
		460	795	(Pn=115%)
		480	830	(Pn=120%)



## Caractéristiques techniques

Les moteurs motive sont réalisés selon les normes internationales IEC ; quelle que soit la forme de construction, toutes les dimensions ont été tirées à partir des tableaux relatifs à la norme IEC 72-1

Les moteurs asynchrones triphasés de la série Delphi sont du type fermé, avec ventilation extérieure. Jusqu'au type 132 y compris, la carcasse est réalisée par moulage sous pression d'alliage d'aluminium et à partir du type 160 la carcasse est en fonte.

The cage rotor is dynamically balanced according to IEC 34-14 and ISO 8821 norms.

Tous les moteurs sont :

multitension, multifréquence 50/60Hz

classe d'isolation F, (H sur demande)

service continu \*S1,

protection IP55, (IP56, 66, 67 et 68 sur demande)



classe de rendement IE2 ou IE3 (CEI 60034-30)

bobinage tropicalisé appropriés pour une alimentation avec convertisseur de fréquence

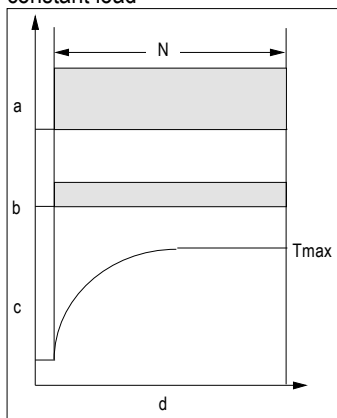
\*S1 - Continuous duty service: operating at constant load



- a= load
- b= electric losses
- c= temperature
- d= time
- N= steady load operating time
- Tmax= max temperature achieved

		Volts		
size	Hz			
		56-132	50	230
220	380			(Pn=100%)
240	415			(Pn=100%)
60	260		440	(Pn=110%)
	220		380	(Pn=100%)
	265		460	(Pn=115%)
	280	480	(Pn=120%)	
132-400	50	400	690	(Pn=100%)
		380	660	(Pn=100%)
		415	720	(Pn=100%)
	60	440	760	(Pn=110%)
		380	660	(Pn=100%)
		460	795	(Pn=115%)
	480	830	(Pn=120%)	





## Condizioni di funzionamento

**Umidità:** L'equipaggiamento elettrico deve essere in grado di funzionare con un'umidità relativa compresa tra il 30 ed il 95% (senza condensazione). Effetti dannosi di condensazioni occasionali devono essere evitati mediante un progetto adeguato dell'equipaggiamento oppure, se necessario, mediante misure aggiuntive (per es. scaldiglie incorporate per il riscaldamento, fori di drenaggio). Gli avvolgimenti sono impregnati a vuoto (vacuum) – procedimento VPI – senza evaporazione, e adatti perciò a climi tropicali

**Altitudine e temperatura:** le potenze indicate si intendono per motori la cui utilizzazione normale di funzionamento è prevista ad una altezza inferiore a 1000m sul livello del mare ed una temperatura ambiente compresa tra i -25°C e +40°C (IEC 34-1): per condizioni di esercizio diverse da quelle specificate (altitudine e/o temperatura superiori) la potenza diminuisce del 10% per ogni 10° di sovratemperatura, e dell'8% per ogni 1000 metri di altitudine in più. Non è consentito usare motori idonei all'utilizzo in atmosfere esplosive in ambienti con temperature fuori dal range -20°C +40°C.

Non è necessario ridurre la potenza nominale nel caso in cui ad una altitudine superiore ai 1000 m e inferiore ai 2000 m corrisponda una temperatura ambiente massima di 30°C o 19°C massimi per un funzionamento ad altitudini tra i 2000 m ed i 3000 m.

**Tensione - Frequenza:** E' ammessa al massimo una variazione della tensione del +/-10% del valore nominale. In questo intervallo i ns motori forniscono la potenza nominale.

Nel funzionamento continuo, ai limiti di tensione sovraindicati, si può avere una fluttuazione della temperatura di riscaldamento fino a +/- 20°C max.

Gli avvolgimenti normali sino calcolati per tensioni di 400V e frequenza 50Hz.

**Isolamento:** l'avvolgimento dello statore è eseguito con filo di rame ed isolamento di cava in classe F, che garantisce una elevata protezione alle sollecitazioni elettriche e meccaniche.

Le temperature massime limite (Tmax) delle classi di isolamento definite dalle norme EN 60034-1 sono

Classe	$\Delta T$ (°C)	Tmax (°C)
A	60+5°	105
E	75+5°	120
B	80+5°	130
F	105+5°	155
H	125	180

I motori Motive, al fine di garantire un servizio continuo S1, sono costruiti in modo tale da avere un livello di riscaldamento classe B o inferiore, quindi ampiamente sotto il loro limite di protezione della classe F.



## Conditions de fonctionnement

**HUMIDITÉ:** Les moteurs sont à même de fonctionner dans les milieux ambiants ayant une humidité relative comprise entre 30 et 95% (sans condensation). Les effets dangereux des condensations occasionnelles doivent être évités à l'aide d'un projet approprié de l'équipement ou, si nécessaire, à l'aide de mesures supplémentaires (par ex. Motive offre des résistances de réchauffage, des trous de purge, des bobinages entièrement résinés).

**ALTITUDE ET TEMPÉRATURE:** Les puissances indiquées sont destinées aux moteurs, qui sont utilisés à une altitude inférieure à 1000 m et à une température ambiante comprise entre -15 et +40° C (IEC 34-1) ; pour des conditions de service différentes de celles susmentionnées (altitude et/ou température supérieures), la puissance diminue de 10% pour toute augmentation de 10° C de la température et de 8% pour tous les 1000 m d'altitude supplémentaires. Pour un fonctionnement du moteur à une altitude variant entre 2000 et 3000 m, il n'est pas nécessaire de réduire la puissance nominale, s'il existe une température ambiante maximale de 30° C ou de 19° C pour les altitudes supérieures à 2000 m ou inférieures à 3000 m.

**VOLTAGE- FRÉQUENCE:** Une variation du voltage correspondant à 10% de la valeur nominale est admise. Nos moteurs sont à même de fournir la puissance nominale dans la plage de tolérance sus mentionnée. Pour le fonctionnement continu, dans les limites du voltage sus mentionnées, il peut y avoir une augmentation maximale de 10° C de l'échauffement limité

**ISOLATION:** le bobinage est effectué avec un fil en cuivre protégé par une double couche de peinture pour la tropicalisation 2 et par une isolation à encoche en classe F, qui garantit une excellente protection aux sollicitations électriques, thermiques et mécaniques. L'isolation entre cuivre et fer à encoche est obtenue par un film qui enveloppe complètement le côté bobine. L'isolation standard est renforcée par un autre film séparateur entre les phases, qui doit protéger le moteur contre les crêtes élevées de tension que l'on a généralement dans l'alimentation avec un variateur de fréquence. Si l'on utilise un variateur accouplé aux moteurs ayant une puissance supérieure à 75kW, il faut faire monter un roulement arrière isolé. Ce dispositif permet d'ouvrir le circuit électrique existant entre le rotor et la carcasse du moteur en évitant que les courants de l'arbre ne circulent dans les roulements, dont les billes et les pistes de roulement peuvent se détériorer précocement.



Les températures maximums (Tmax) des classes d'isolation définies par la norme EN60034-1 sont

Class	$\Delta T$ (°C)	Tmax (°C)
A	60+5°	105
E	75+5°	120
B	80+5°	130
F	105+5°	155
H	125	180

Les moteurs Delphi sont construits de manière à conserver d'importantes marges de sécurité contre des éventuelles surcharges, grâce au fait qu'ils ont une valeur d'échauffement, à la puissance nominale, très inférieure à la limite supportée par leur classe d'isolation. Cet aspect augmente considérablement la durée de vie du moteur.





## Protezioni elettriche e termiche

le protezioni devono essere scelte in base alle specifiche condizioni di esercizio secondo le norme EN 60204-1 (per motori destinati ad essere installati in atmosfere esplosive, vedi EN60079-14 ed EN61241-14).

### Protezioni esterne

Si possono avere:



1. Protezione contro sovracorrenti e cortocircuiti; questa protezione si può ottenere tramite interruttore magnetotermico o con fusibili; questi devono essere tarati sulla corrente d'impiego del motore.



2. Protezione contro i sovraccarichi, tramite relè termico che controlla un teleruttore di potenza a monte del motore.
3. protezione contro la sovravelocità, ad esempio nel caso in cui il carico meccanico possa trascinare il motore e questa possa diventare una condizione di pericolo.
4. protezione, se particolari condizioni di funzionamento in sincronia con altre macchine o parti di macchine lo richiedono, contro l'interruzione della tensione di alimentazione o la riduzione della stessa tramite relè di minima tensione che controlla un interruttore automatico di potenza sezionatore



## Protezioni termiche interne: (secondo CEI 2-3 / IEC 34-1)

Le protezioni elettriche presenti sulla linea di alimentazione del motore possono essere insufficienti ad assicurare la protezione dai sovraccarichi. Infatti, se peggiorano le condizioni di ventilazione, il motore si surriscalda ma le condizioni elettriche non si modificano e ciò inibisce le protezioni sulla linea. Si ovvia a questo inconveniente installando intimamente protezioni sugli avvolgimenti:



### dispositivo bimetallico PTO

è un dispositivo elettromeccanico che, normalmente chiuso, una volta raggiunta la temperatura di scatto si apre elettricamente; si ripristina automaticamente quando la temperatura scende sotto il limite di scatto.

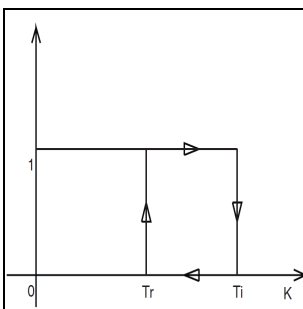

Tr= opening temperature (il motore si ferma)

Ti= re-closing temperature (il motore torna a funzionare)

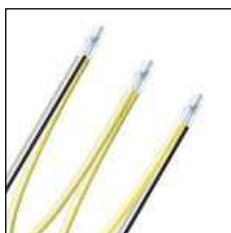

### dispositivo termistore PTC

questo dispositivo varia la sua resistenza in modo repentino e positivo una volta raggiunta la temperatura di intervento. I motori dalla taglia 160 alla taglia 355L sono equipaggiati di serie con 3 termistori PTC immersi nell'avvolgimento, con temperatura di intervento di 130°C nei motori in classe F (serie standard DELPHI) o 160°C nei motori in classe H+ (serie DELFIRE).

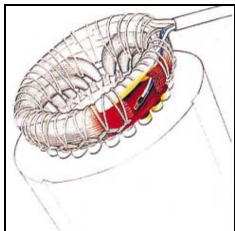

posizione PTC

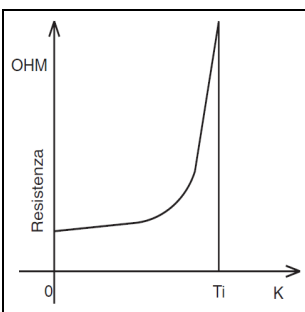

$T_i$  = temperatura di intervento

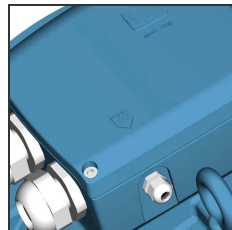

grandezza 160-400  
pressacavo per PTC



### dispositivo PT100

è un dispositivo che varia con continuità, e in modo crescente, la sua resistenza in funzione della temperatura. Si presta al rilievo continuo di temperatura degli avvolgimenti tramite apparecchiature elettroniche.

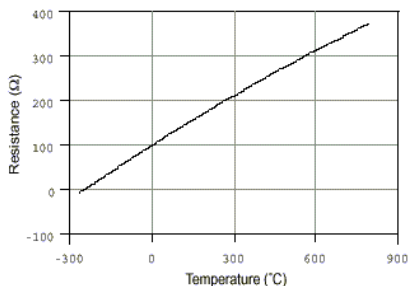

---

Nel rispetto della norma IEC34-1 tutti i motori possono sopportare sovraccarichi di 1,5 volte la corrente nominale per 2 minuti e 1,6 volte la coppia nominale per 15 secondi (V e Hz nominali)

---





## SCHEAPT - Modulo di controllo sonde termiche motore

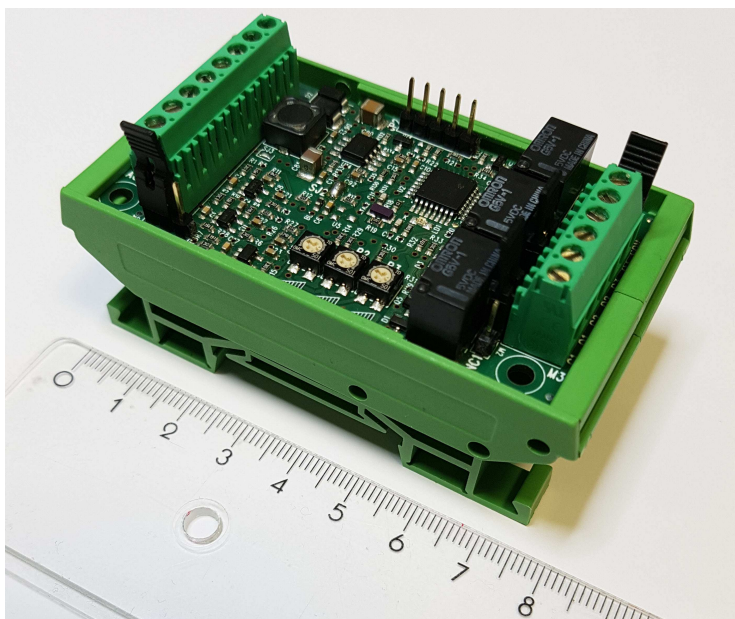

[https://www.motive.it/upload/documenti/manuali/SCHEAPT\\_ita.pdf](https://www.motive.it/upload/documenti/manuali/SCHEAPT_ita.pdf)





## Protection des moteurs

Les protections doivent être choisies en fonction des conditions spécifiques d'exercice suivant les normes EN 60204-1 (pour moteurs ATEX, voir aussi EN60079-14 et EN61241-14).



1. Protection contre les surintensités et les courts-circuits. cette protection peut être obtenue via le disjoncteur magnétothermique ou avec des fusibles; ceux-ci doivent être calibrés sur le courant du moteur..



2. Protection contre les surcharges par relais thermique qui commande un contacteur de ligne électrique en amont du moteur.
3. Protection contre la vitesse excessive, si l'application le requiert, au cas où par exemple la charge mécanique pourrait entraîner le moteur et constituer ainsi un véritable danger.
4. Cette protection pourrait être utile en cas de conditions particulières de fonctionnement en synchronie avec d'autres machines ou parties de machines: il s'agit d'une protection contre l'interruption d'alimentation ou la réduction de cette dernière, à travers un relais de tension minimum servant à contrôler un interrupteur automatique de puissance sectionneur.



Les protections électriques, présentes sur la ligne d'alimentation du moteur, pourraient ne pas suffire à garantir la protection contre les surcharges. En effet, si les conditions de ventilation empirent, le moteur chauffe, mais les conditions électriques ne varient nullement empêchant ainsi toute intervention des protections sur la ligne. Cet inconvénient peut être résolu en installant des protections sur les bobinages.



- Dispositif bimétallique PTO Il s'agit d'un dispositif électromécanique, normalement fermé, qui s'ouvre électriquement lorsquela température atteint le niveau de déclenchement ; il retourne dans sa position normale, dès que la température descend en dessous du niveau de déclenchement. Ce dispositif n'est pas permis sur les moteurs ATEX "Delphi Ex - II 3G Ex nA"

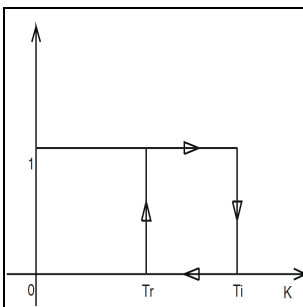

Tr= opening temperature (il motore si ferma)

Ti= re-closing temperature (il motore torna a funzionare)

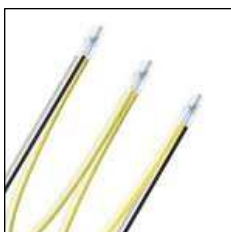

- Dispositif de thermistance PTC La résistance de ce dispositif varie de façon subite et positive, aussitôt que la température d'intervention est atteinte. Les moteurs de la taille 160 à la taille 355L sont équipés en standard de 3 thermistances PTC immergées dans le bobinage, avec une température d'activation de 130°C dans les moteurs classe F (série DELPHI standard) ou 160°C dans les moteurs classe H+ (série DELFIRE).

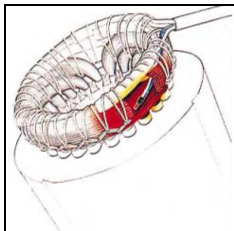

posizione PTC

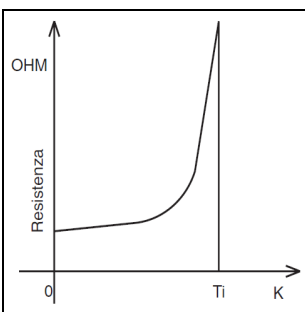

$T_i$ = temperatura di intervento

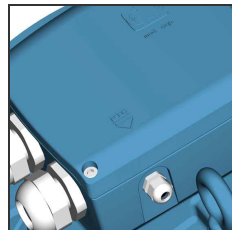

grandezza 160-400  
pressacavo per PTC



- Dispositif PT100La résistance de ce dispositif varie en continu et de façon croissante en fonction de la température. Il peut être utilisé pour le relevé en continu de la température des bobinages, à travers des appareils électroniques.

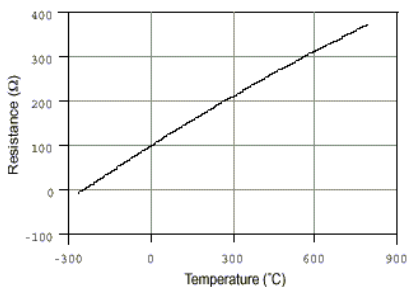

---

Conformément à la norme IEC34-1, tous les moteurs peuvent être exposés à surcharger de 1,5 fois la courant nominale pour 2 minutes et 1,6 fois le moment de torsion pour 15 sec (à V évalué et à Hz)and Hz)

---



## SCHEDAPT - Carte de contrôle des sondes thermiques du moteur

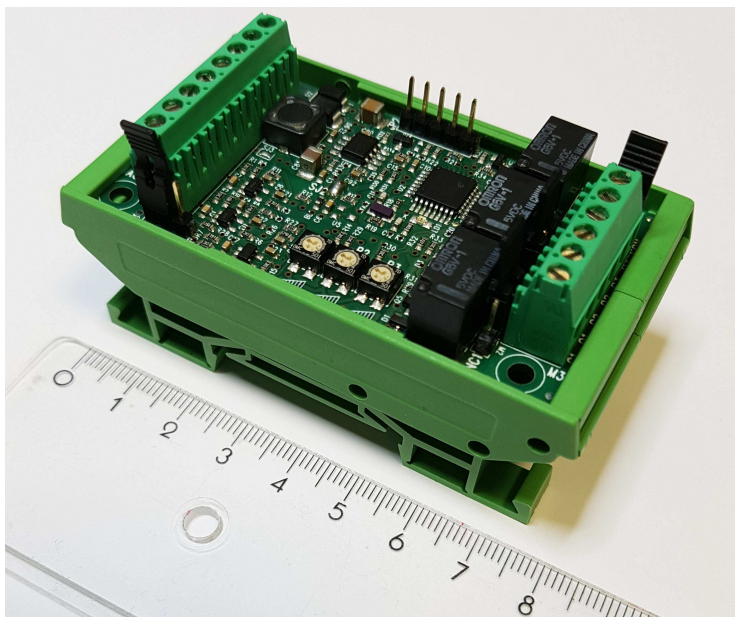

[https://www.motive.it/upload/documenti/manuali/SCHEDAPT\\_fra.pdf](https://www.motive.it/upload/documenti/manuali/SCHEDAPT_fra.pdf)





## collegamento elettrico

Le operazioni di collegamento alla rete elettrica (valide anche per circuiti ausiliari) devono essere effettuate in ottemperanza alle seguenti prescrizioni:

- qualunque operazione sull'impianto deve essere effettuata da personale addestrato;
- il motore deve essere disattivato ed isolato;
- assicurarsi che non sia possibile un riavvio accidentale;
- accertarsi dell'assenza di tensione;
- dove la rete non sopporta la corrente d'inserimento diretto, il motore può essere avviato mediante un commutatore stella-triangolo. Ciò può avvenire soltanto nei motori il cui collegamento degli avvolgimenti per la tensione nominale è triangolo.
- l'allacciamento deve essere effettuato in modo tale da garantire un collegamento elettrico duraturo e sicuro;
- assicurare il corretto dimensionamento dei cavi di alimentazione
- assicurarsi che nella scatola collegamenti non siano presenti né corpi estranei, né sporcizia o umidità. Controllare l'appropriata chiusura di tutti pressacavi e tappi non utilizzati e non, serrare bene il coperchio della scatola coprimorsettiera per prevenire la penetrazione di polvere ed acqua;
- nel caso di motori dotati di freno (serie AT..), verificare il corretto funzionamento del freno prima della messa in servizio;
- il cambio del senso di rotazione si può ottenere intercambiando le due fasi.

## electrical connection

The operations for the connection to the electric network (valid for auxiliary circuits, too) must be performed in compliance with the following indications:

- any operation on the plant must be run by trained personnel;
- the motor must be disabled and isolated;
- make sure that a casual start can not occur;
- make sure that there is no voltage;
- If the network does not sustain the direct input voltage, the motor can be started by means of a star/delta commutator, which is possible only in motors where the connection of the winding for rated voltage is delta.
- the electric connection must be made in order be long-lasting and safe;
- assure correct dimensioning of power supply cables
- make sure that in the box for the connection there is neither foreign bodies, nor dirty/humid parts. Recheck the proper closure of used and unused cable glands and caps and tight terminal box lid in order to prevent the entrance of dust and water;
- when testing without output components secure the keyway;
- in motors with brake (AT.. series), please verify the brake switching before the starting process;
- you can change to counter-rotation an be obtained by interchanging the two phases.





## Schemi di collegamento (DELPHI 3PH)

Motore tipo	56	63-100	112	132	160-180	200-225	280-355	400
pressacavo	M16	M20	M25	M32	2xM40	2xM50	2xM63	3xM63
diam cavi mm	3-7	10-14	9-16	13-20	20-26	25-31	29-35	29-35



Cod. Motive cavo	descrizione cavo	Corrente motore In [A]
CAVOFG16OR4G1.5MT	FG16OR 4G1,5 mm <sup>2</sup>	0 ÷ 10
CAVOFG16OR4G2.5MT	FG16OR 4G2,5 mm <sup>2</sup>	11 ÷ 16
CAVOFG16OR4G4MT	FG16OR 4G4 mm <sup>2</sup>	17 ÷ 22
CAVOFG16OR4G6MT	FG16OR 4G6 mm <sup>2</sup>	23 ÷ 32
CAVOFG16OR4G10MT	FG16OR 4G10 mm <sup>2</sup>	33 ÷ 50
CAVOFG16OR4G16MT	FG16OR 4G16 mm <sup>2</sup>	51 ÷ 64
CAVOFG16OR4G25MT	FG16OR 4G25 mm <sup>2</sup>	65 ÷ 90
CAVOFG16OR4G35MT	FG16OR 4G35 mm <sup>2</sup>	91 ÷ 110
CAVOFG16OR4G50MT	FG16OR 4G50 mm <sup>2</sup>	111 ÷ 130
CAVOFG16OR4G70MT	FG16OR 4G70 mm <sup>2</sup>	131 ÷ 170
CAVOFG16OR4G95MT	FG16OR 4G95 mm <sup>2</sup>	171 ÷ 200
CAVOFG16OR4G120MT	FG16OR 4G120 mm <sup>2</sup>	201 ÷ 240



CAVOFG16OR4G150MT	FG16OR 4G150 mm <sup>2</sup>	241 ÷ 270
CAVOFG16OR4G185MT	FG16OR 4G185 mm <sup>2</sup>	271 ÷ 305

Il collegamento dei cavi d'alimentazione alla morsettiere deve essere eseguito capocorda su capocorda

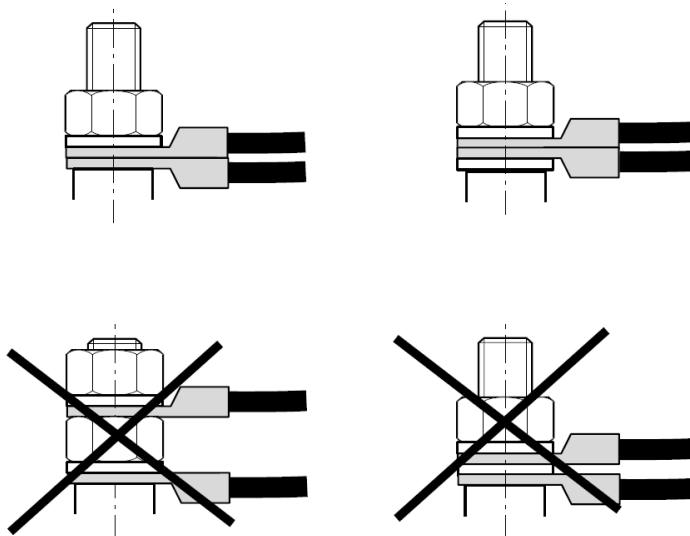

Coppia di serraggio (N.m) sui dadi delle morsettiere:

 Nm	M4	M5	M6	M8	M10	M12	M16
steel	2	3,2	5	10	20	35	65
brass	1	2	3	6	12	20	50



Gli avvolgimenti dei motori trifase serie Delphi possono essere collegati a stella o a triangolo.

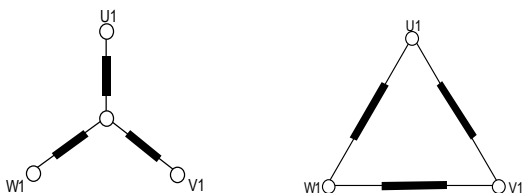

### Collegamento a stella

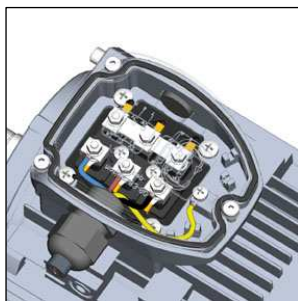

Il collegamento a stella si ottiene collegando insieme i terminali W2, U2, V2 e alimentando i terminali U1, V1, W1.

### Collegamento a triangolo

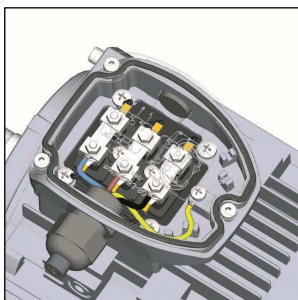

Il collegamento a triangolo si ottiene collegando la fine di una fase all'inizio della fase successiva.

Per gli schemi di collegamento dei motori autofrenanti, vedi il capitolo “serie Delphi AT...”.



## Schémas de couplage (DELPHI 3PH)

Motore tipo	56	63-100	112	132	160-180	200-225	280-355	400
Presse-étoupe	M16	M20	M25	M32	2xM40	2xM50	2xM63	3xM63
câbles diam mm	3-7	10-14	9-16	13-20	20-26	25-31	29-35	29-35



Motive code	Cable description	Motor current In [A]
CAVOFG16OR4G1.5MT	FG16OR 4G1,5 mm <sup>2</sup>	0 ÷ 10
CAVOFG16OR4G2.5MT	FG16OR 4G2,5 mm <sup>2</sup>	11 ÷ 16
CAVOFG16OR4G4MT	FG16OR 4G4 mm <sup>2</sup>	17 ÷ 22
CAVOFG16OR4G6MT	FG16OR 4G6 mm <sup>2</sup>	23 ÷ 32
CAVOFG16OR4G10MT	FG16OR 4G10 mm <sup>2</sup>	33 ÷ 50
CAVOFG16OR4G16MT	FG16OR 4G16 mm <sup>2</sup>	51 ÷ 64
CAVOFG16OR4G25MT	FG16OR 4G25 mm <sup>2</sup>	65 ÷ 90
CAVOFG16OR4G35MT	FG16OR 4G35 mm <sup>2</sup>	91 ÷ 110
CAVOFG16OR4G50MT	FG16OR 4G50 mm <sup>2</sup>	111 ÷ 130
CAVOFG16OR4G70MT	FG16OR 4G70 mm <sup>2</sup>	131 ÷ 170
CAVOFG16OR4G95MT	FG16OR 4G95 mm <sup>2</sup>	171 ÷ 200
CAVOFG16OR4G120MT	FG16OR 4G120 mm <sup>2</sup>	201 ÷ 240



CAVOFG16OR4G150MT	FG16OR 4G150 mm <sup>2</sup>	241 ÷ 270
CAVOFG16OR4G185MT	FG16OR 4G185 mm <sup>2</sup>	271 ÷ 305

Connexion correcte et incorrecte des câbles d'alimentation au bornier:

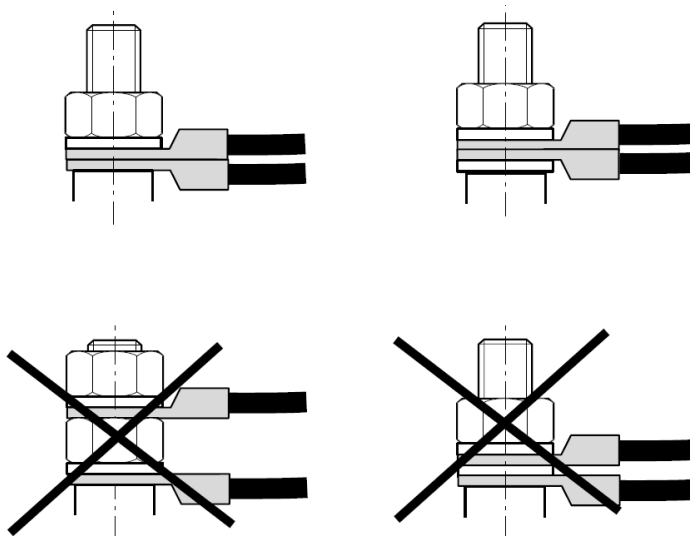

Couple (Nm) sur les écrous du bornier:

 Nm	M4	M5	M6	M8	M10	M12	M16
	steel	2	3,2	5	10	20	35
brass	1	2	3	6	12	20	50



Les bobinages des moteurs triphasés Motive peuvent être couplés en étoile ou en triangle..

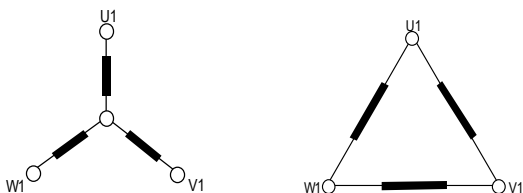

### COUPLAGE EN ÉTOILE

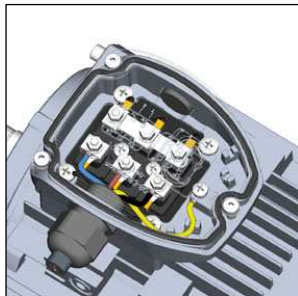

Le couplage en étoile est réalisé en reliant les bornes W2, U2, V2 et en alimentant les bornes U1, V1 et W1..

### COUPLAGE EN TRIANGLE

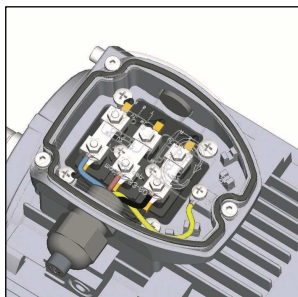

Le couplage en triangle est réalisé en couplant la fin d'une phase avec le début de la phase successive.

Le courant de phase  $I_{ph}$  et la tension de phase  $U_{ph}$  sont les suivants :  $I_{ph} = I_n / \sqrt{3}$  -  $U_{ph} = U_n$

avec  $I_n$  et  $U_n$  se référant au couplage en triangle.

**Per gli schemi di collegamento dei motori autofrenanti, vedi il capitolo "serie Delphi AT..."**





**Double polarity motor,  
single winding (Dahlander)  
2/4 – 4/8 Poles**

**Motore doppia polarità  
singolo avvolgimento (Dahlander)  
2/4 – 4/8 Poli**

High-speed connection **400 YY**  
Connessione alta velocità **400 YY**

Low-speed connection **400 Δ**  
Connessione basa velocità **400 Δ**

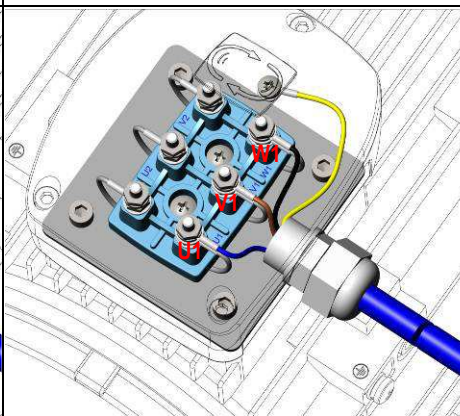
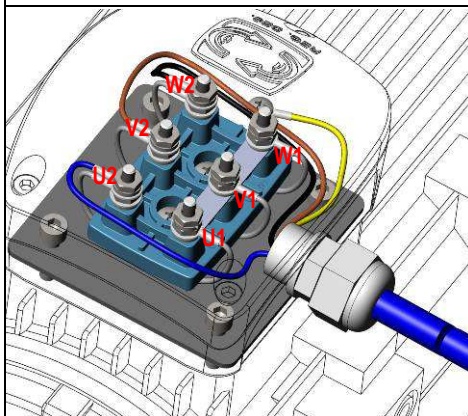
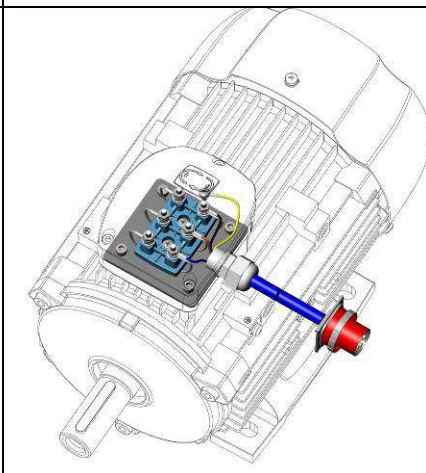
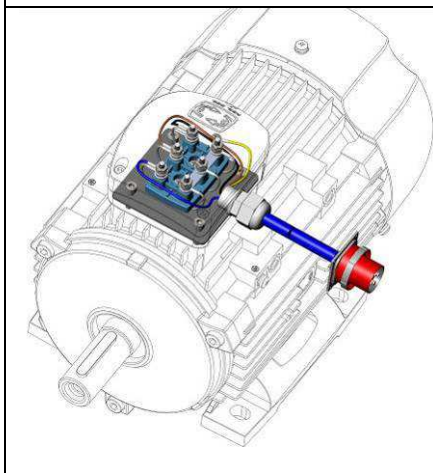

To use the 2 speeds, you must adopt a 6+1 wires cable and connect an external switch

Per sfruttare entrambe le velocità, adottare un cavo a 6+1 fili e collegare un commutatore esterno



**Double polarity motor,  
with double winding**  
2/6 – 2/8 – 4/6 – 6/8 Poles

**Motore doppia polarità  
a doppio avvolgimento**  
2/6 – 2/8 – 4/6 – 6/8 Poli

High-speed connection **400 Y**

Connessione alta velocità **400 Y**

Low-speed connection **400 Y**

Connessione bassa velocità **400 Y**

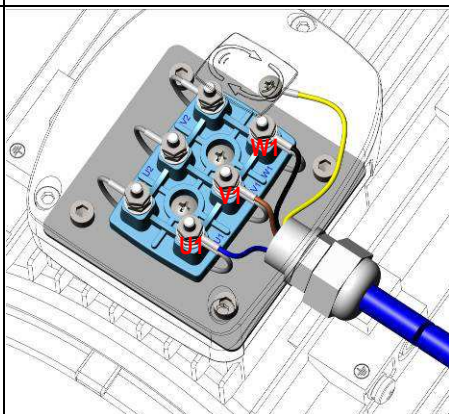
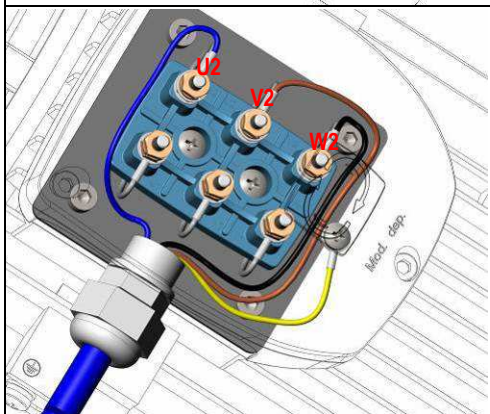
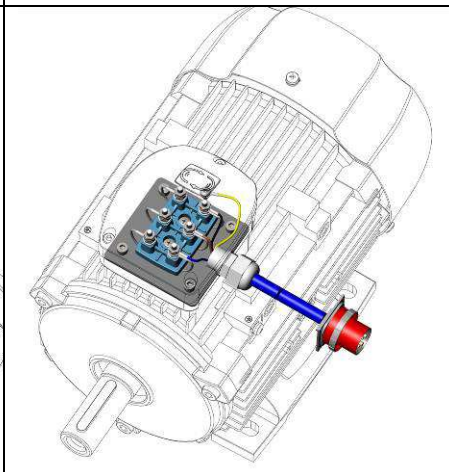
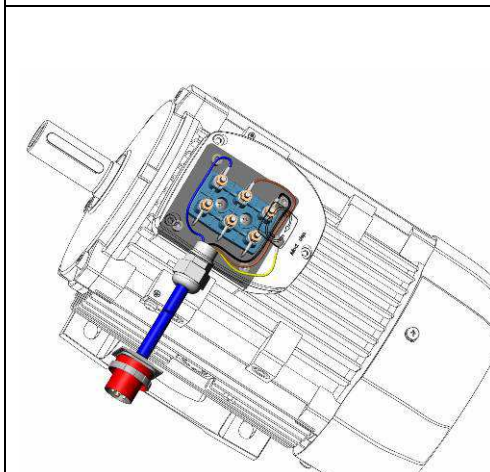

To use the 2 speeds, you must adopt a 6+1 wires cable and connect an external switch

Per sfruttare entrambe le velocità, adottare un cavo a 6+1 fili e collegare un commutatore esterno



## Moteurs monophasés

## Motori monofase MONO

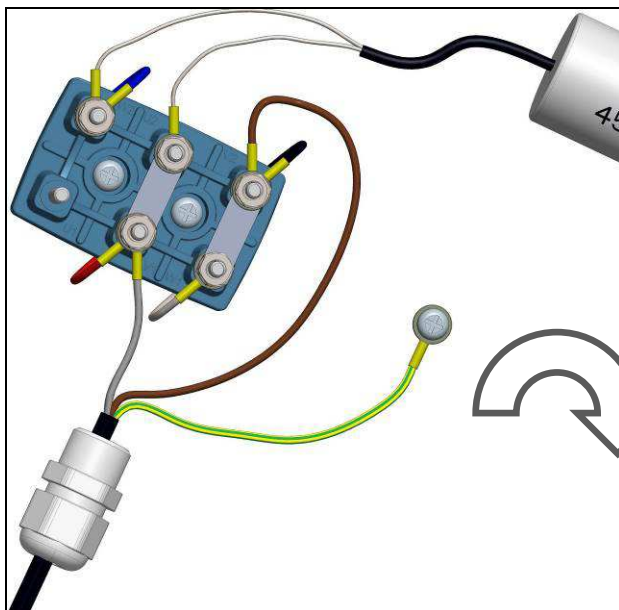
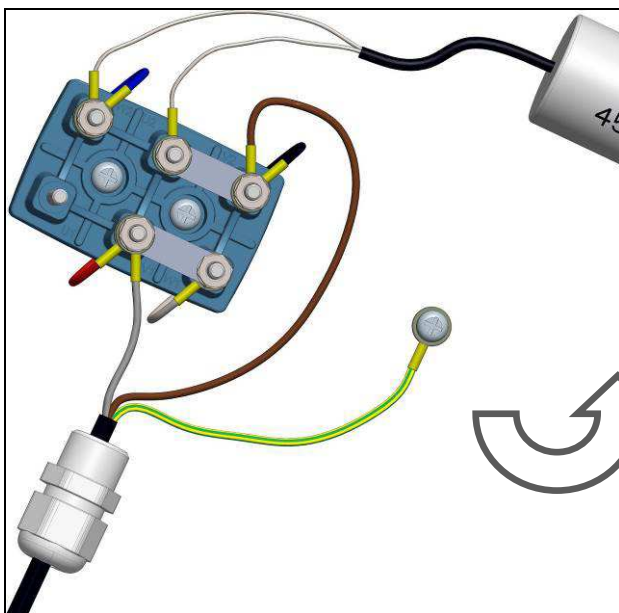



### Starting Capacitor 3 wires MONO

### Condensatore di spunto a 3 fili MONO

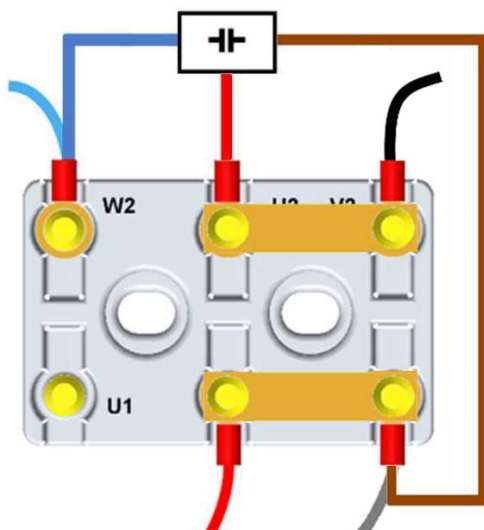
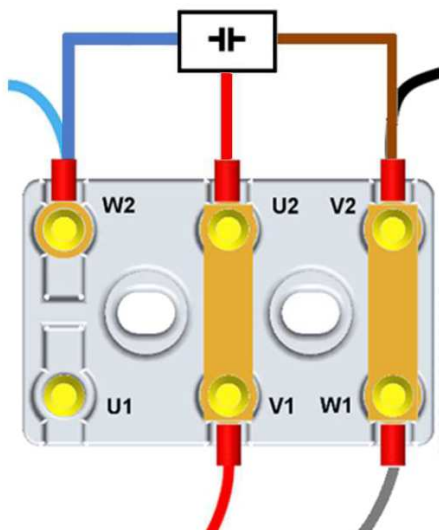

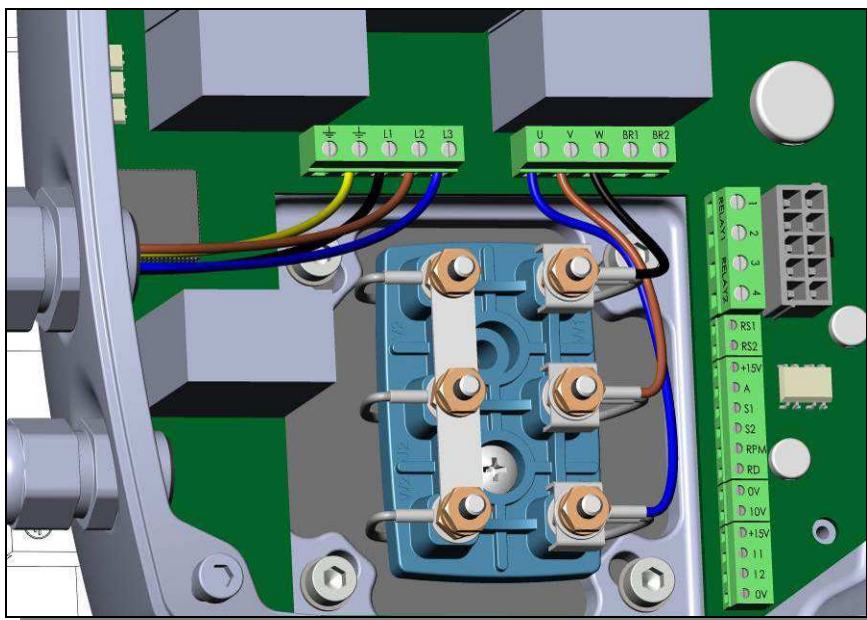
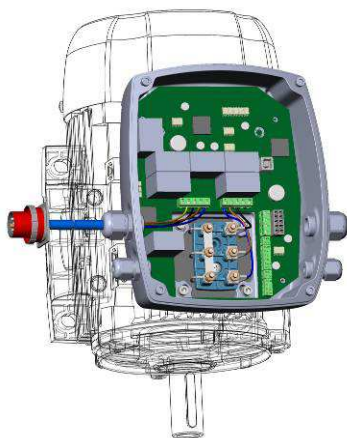
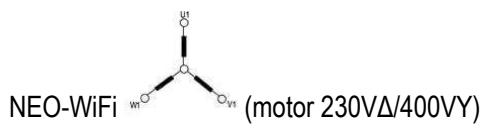



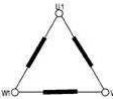

NEO-WiFi  (motor 400VΔ/690VY)

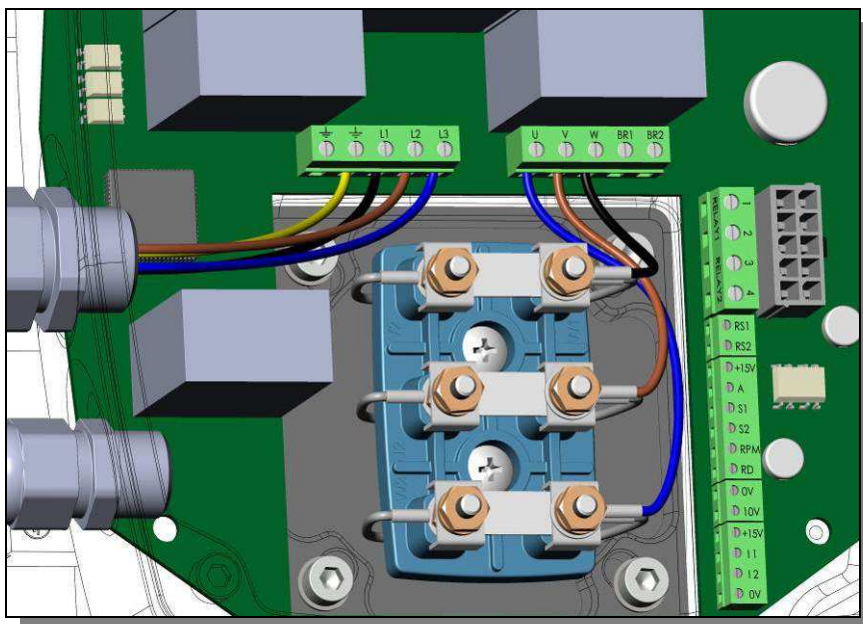
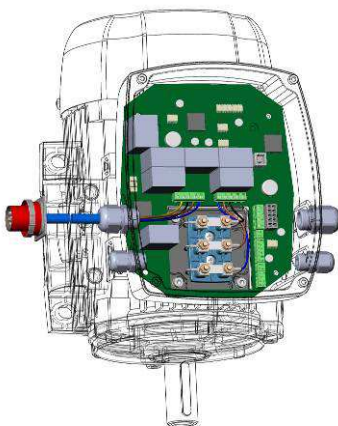





## Messa in servizio

Prima dell'avviamento del motore effettuare un controllo generale, assicurandosi di aver rispettato tutte le procedure di installazione. In particolar modo verificare:

- che la tensione di alimentazione del motore corrisponda a quella prevista in targa;
- controllare il raccordo della piastrina di collegamento, serrare tutti i suoi dadi e fissare il coperchio della morsettiera avendo cura di non danneggiare la guarnizione;
- verificare la libera rotazione dell'albero manualmente;
- controllare se tutte le fasi hanno tensione e, possibilmente, misurare che il loro valore sia conforme al valore nominale di targa.

## Start

Before starting make an overall check of the motor to make sure that all the indications about installation have been applied. In particular

- make sure that the voltage of the motor is equivalent to the one expected (see motor plate) and
- check the union of the connecting link, close all its dies and secure the cover of the terminal board without damaging the gasket;
- verify the free rotation of the motor shaft manually;
- check if there is voltage in all the phases and eventually measure their value to check their conformity to the plate values.

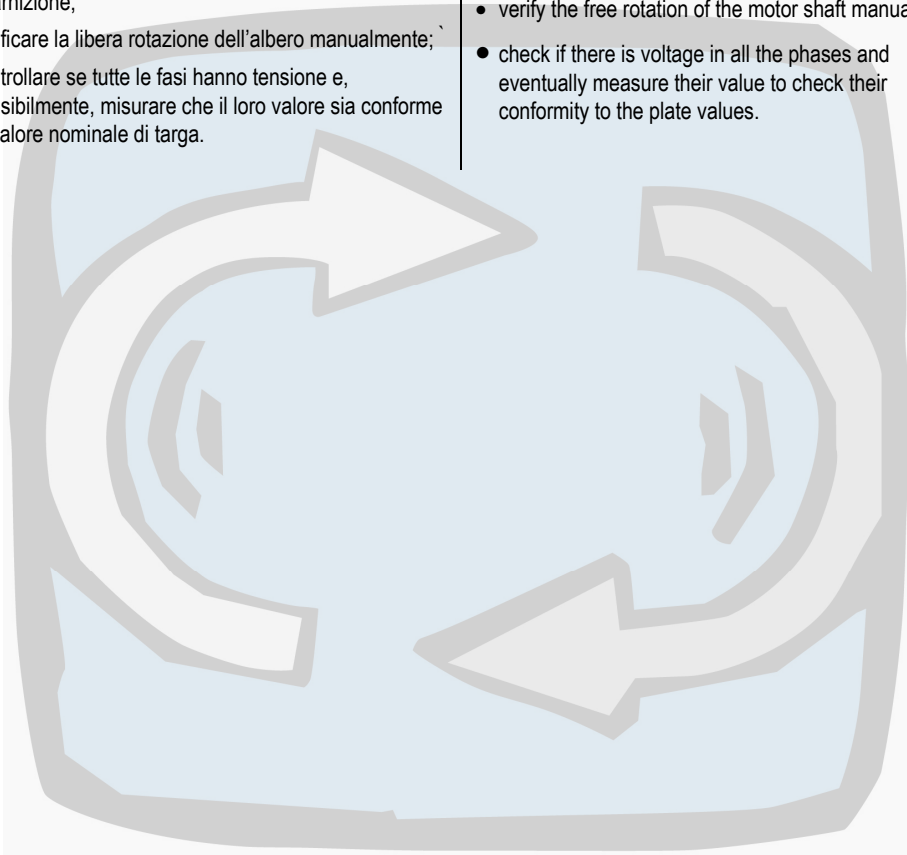



## Toit de protection

Pour applications en plein air avec montage en position V5 – V18 – V1 – V15, il est recommandé de monter un toit de protection contre la pluie. Cette opération peut également être réalisée dans des lieux destinés aux travaux textiles.

Le TOIT de PROTECTION est obligatoire sur les moteurs ATEX montés en position V5 – V18 – V1 – V15

## Tettuccio parapioggia

Per applicazioni all'aperto con montaggio in posizione V5 – V18 – V1 – V15 (albero in basso) è consigliabile montare un tettuccio parapioggia. Questa esecuzione si può utilizzare anche in ambienti per lavorazioni tessili.

Il tettuccio para-pioggia è obbligatorio nei motori atex, quando gli stessi vengono montati in posizione V5 – V18 – V1 – V15

tipo	L
63	215
71	323
80	369
90S	403
90L	428
100	469
112	453
132S	573
132M	613
160M	770
160L	825
180M	915
180L	955
200L	1025
225S	1155
225M	1160
250M	1220
280S	1265
280M	1315
315S	1540
315M	1570
315L	1680
355M	1840
355L	1870

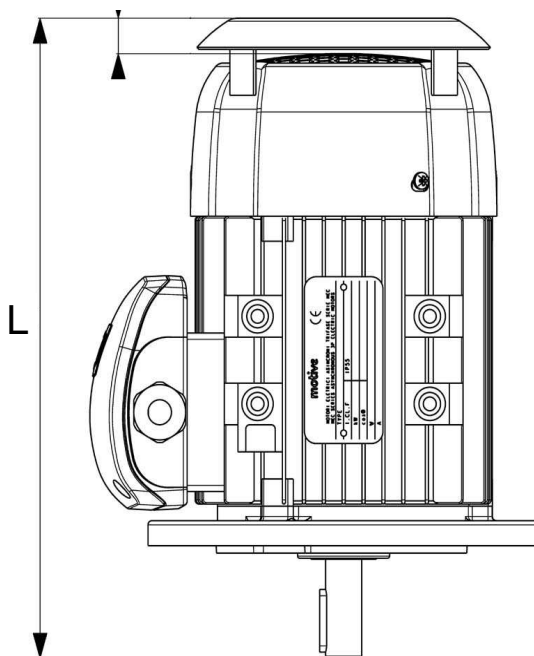



## Serie Delphi AT..

I motori autofrenanti serie Delphi ATDC, AT24, ATTD e ATTD24 prevedono l'impiego di freni a pressione di molle alimentati in corrente continua, calettati saldamente su uno scudo in ghisa nella parte posteriore del motore. AT24 e ATTD24 sono dotati di freni a 24V per poter essere alimentati direttamente dalle separate uscite 24V di cui la maggior parte degli inverter sono dotati.

Si possono effettuare due tipi diversi di regolazione per i motori ATDC e AT24.

### Regolazione del traferro S

Per un corretto funzionamento, il traferro S tra l'elettromagnete ⑦ e l'ancora mobile ① dev'essere compreso tra i seguenti valori:

Motore tipo	traferro S (mm)
63~71	0.20~0.30
80~100	0.40~0.50
112~280	0.50~0.60

La regolazione si effettua agendo sulle bussole filettate ⑩ controllando mediante spessore che si sia raggiunto il valore di traferro desiderato. Per i freni grandezza 63, 71, 80 e 90 la regolazione del traferro S non è modificabile.

### Regolazione della coppia frenante

Si ottiene agendo sui grani di regolazione ⑨. La coppia frenante è già regolata dalla Motive sul valore massimo e si consiglia di non variarla.

## DELPHI AT..

Les moteurs frein de la série Delphi ATDC, AT24, ATTD et ATTD24 prévoient l'emploi de freins à pression de ressorts alimentés en courant continu, clavetés solidement sur un flasque en fonte dans la partie arrière du moteur. Les AT24 et ATTD24 sont équipés de freins à 24V pour pouvoir être alimentés directement par les sorties séparées 24V dont la majeure partie des variateurs sont équipés.

Il est possible d'effectuer deux types de réglage :

### Réglage de l'entrefer S

Pour un bon fonctionnement, l'entrefer S entre l'électro-aimant ⑦ et la fixation mobile ① doit être compris dans les valeurs suivantes:

Motour type	S air gap (mm)
63~71	0.20~0.30
80~100	0.40~0.50
112~280	0.50~0.60

Le réglage s'effectue en agissant sur les douilles filettées ⑩ et en contrôlant, à l'aide d'un épaisseurmètre, que l'on a obtenue la valeur de l'entrefer désirée. Pour les freins de tailles 63, 71, 80 et 90, le réglage de l'entrefer S ne peut pas être modifié.

### Réglage du couple de freinage

S'obtient en agissant sur la vis de réglage (moteurs ATDC et ATTD) ou sur la manette (moteurs AT24 et ATTD24). Il est déjà réglé au maximum par Motive.

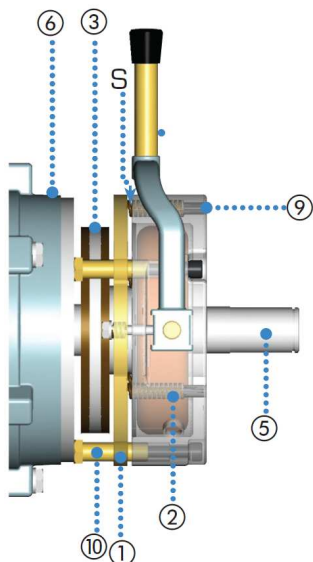

- ① Ancora mobile
- ② Molle
- ③ Disco freno (ferodo)
- ④ Trascinatore
- ⑤ Albero motore
- ⑥ Flangia motore
- ⑦ Bobina
- ⑧ Leva di sblocco
- ⑨ Grani di regolazione
- ⑩ Bussola filettata
- ⑪ manopola di regolazione coppia
- ⑫ piastra di connessione

**S** Traferro

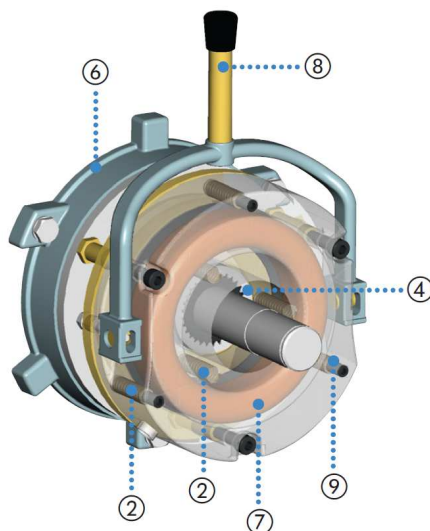

- ① Ancre mobile
- ② Ressorts
- ③ Disque du frein
- ④ Dé d'entraînement
- ⑤ Arbre moteur
- ⑥ Palier moteur
- ⑦ Bobine
- ⑧ Levier de déblocage
- ⑨ Grain de réglage
- ⑩ Douille filetée
- ⑪ Bouton de réglage de couple
- ⑫ Plaque de connexion

**S** Entrefer

Nota: L'utilizzo del freno non è ammesso nei motori atti ad essere installati in ambienti con atmosfere esplosive (zona 2 - gas). Per ulteriori dettagli vedere l'"addendum ATEX".

Notez : les freins généralement ne sont pas admis dans les moteurs ATEX. Pour détails, voir le dossier "l'addenda d'ATEX"



ATTD

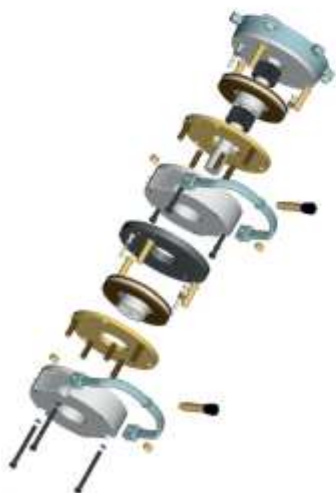

ATB4



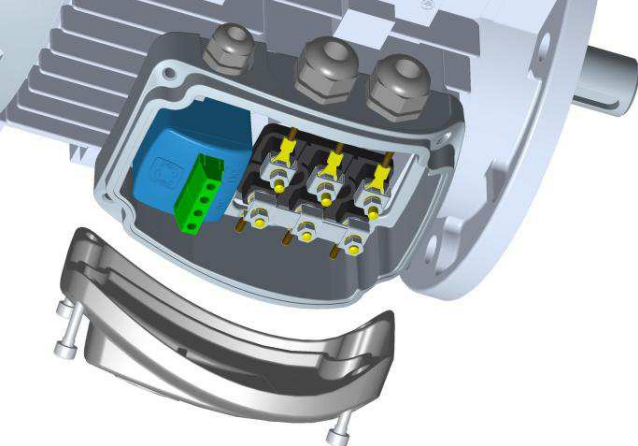

I freni Motive ATDC sono freni a corrente continua alimentati da un raddrizzatore di tensione installato nel coprimorsettiera..

Le prestazioni di velocità mSec, potenza W, ed il momento torcente Nm di tali freni, sono esposti nel sito [www.motive.it](http://www.motive.it).

La seguente tabella riporta le

alimentazioni di raddrizzatore e freno nella serie ATDC

Type	Volt in entrata al raddrizzatore [Vac]	Volt da raddrizzatore a freno [Vdc]
ATDC 63-100	230	104
ATDC 112-280	400	180

A meno di diversa richiesta scritta in fase d'ordine, Motive fornisce i motori ATDC con il raddrizzatore già connesso al morsetto principale del motore attraverso 2 ponticelli (fig. 1, 2, 3 e 4), al fine di consentire che l'alimentazione diretta sul motore agisca contemporaneamente sul freno.

In nessun caso il raddrizzatore può essere alimentato da convertitore di frequenza / inverter / soft-start.

In caso di alimentazione del motore da inverter (fig. 5a e 5b), o con tensione speciale, o ad avviamento a tensione ridotta, o in presenza di carichi aventi un possibile movimento inerziale, come i carichi sollevati (in questo caso allo spegnimento dell'alimentazione del motore, il carico può muovere il motore e farlo agire come generatore sul raddrizzatore del freno e quindi sul freno, evitandone il blocco) bisogna provvedere a scollegare tali ponticelli predisposti da motive ed alimentare separatamente il raddrizzatore (cap.



“schemi di collegamento”, fig. 5, 6, e 7).

Il raddrizzatore in versione TA risolve il problema del carico inerziale senza richiedere un'alimentazione separata del raddrizzatore (fig 3 and 4)

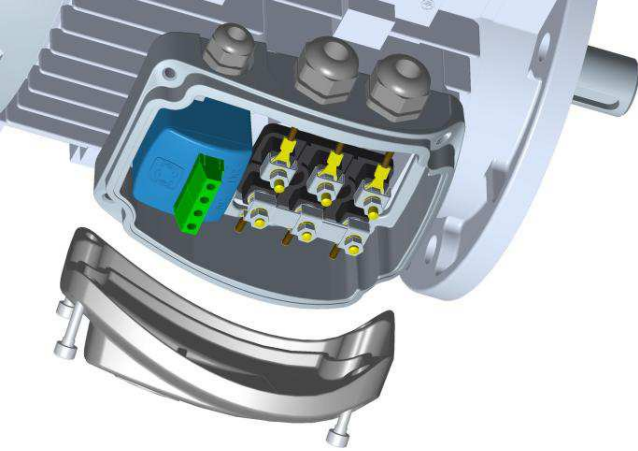

Les freins ATDC sont freins à courant continue DC alimentées par un redresseur qui se trouve dans la boîte à borne du moteur

Les prestations Watt, Nm et vitesse de tous freins sont indiquées dans le catalogue sur [www.motive.it](http://www.motive.it).

La table suivante montre les tensions sur le redresseur et le frein dans le modèle ATDC

Type	input voltage on rectifier [Vac]	output voltage to brake [Vdc]
ATDC 63-100	230	104
ATDC 112-280	400	180

Quand en n'y ait une différente demande du client, les moteurs ATDC sont fournis avec le redresseur déjà raccordé directement au principal borne du moteur, pour faire démarrer le moteur et l'ouverture du frein au même temps

The rectifier cannot be power-supplied by frequency inverters or soft-start devices

Dans le cas où le moteur est alimenté par un convertisseur de fréquence, ou dans le cas où le moteur est utilisé pour déplacer des charges qui peuvent avoir un mouvement d'inertie,

comme les poids soulevés (un tel mouvement d'inertie peut déplacer le moteur quand l'alimentation est arrêtée et le moteur peut agir comme un générateur sur le redresseur évitant la fermeture du frein), en doit séparer l'alimentation du terminal principal du moteur par l'alimentation du redresseur (ATDC) (fig. 5a, 5b, 6 and 7).



TA special rectifier permits to solve the problem of inertial movements with no need for a separate power supply to the rectifier (fig 3 and 4)





ATDC 112-280  - 400Vac/180Vdc rectifier (fig.1)

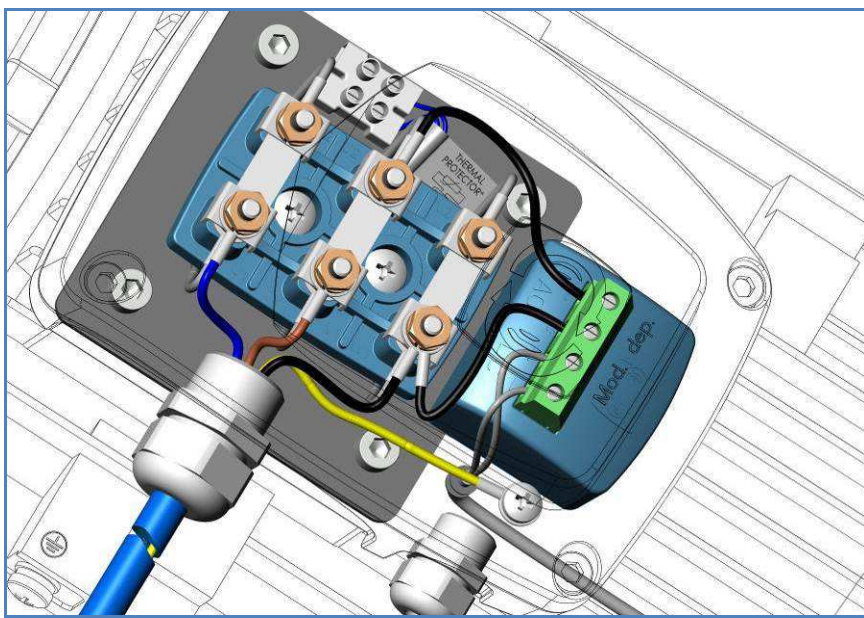
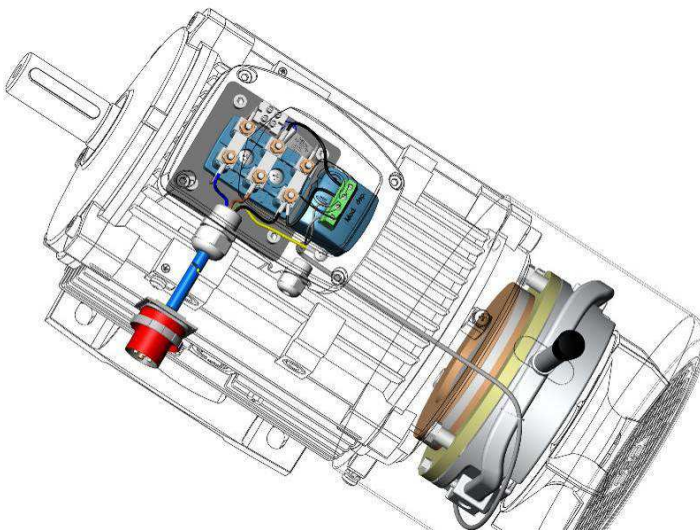





ATDC 63-100  - 230Vac/104Vdc rectifier (fig.2)

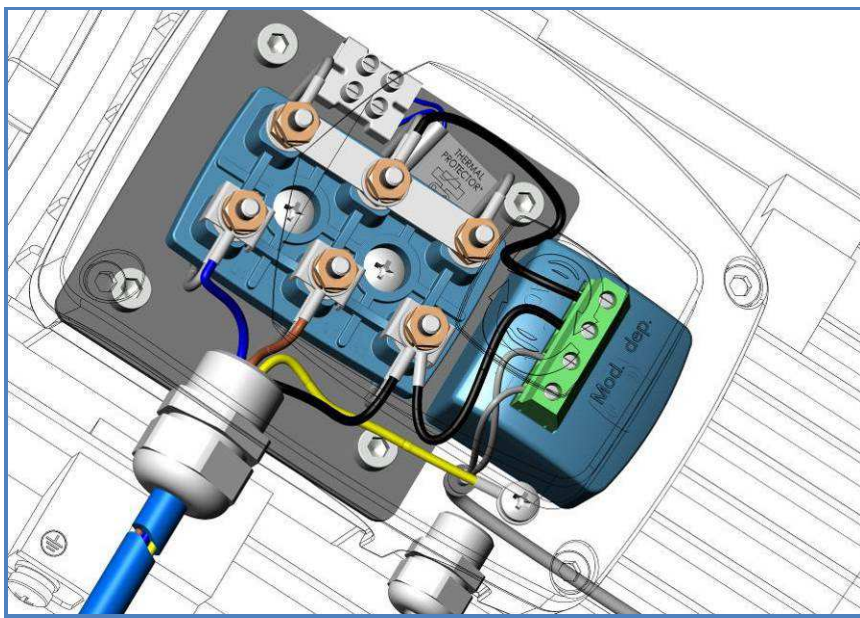
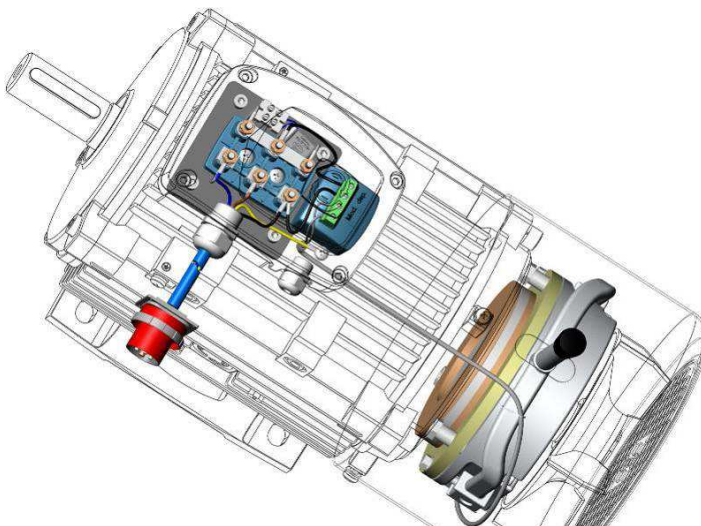



ATDC  400Vac/180Vdc TA rectifier (fig.3) *\*Not suitable if the motor is controlled by inverter*

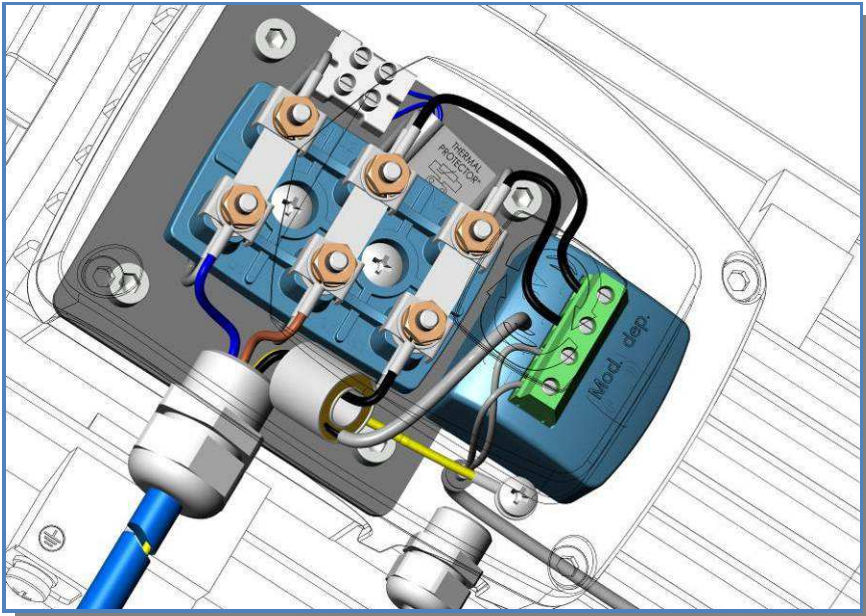
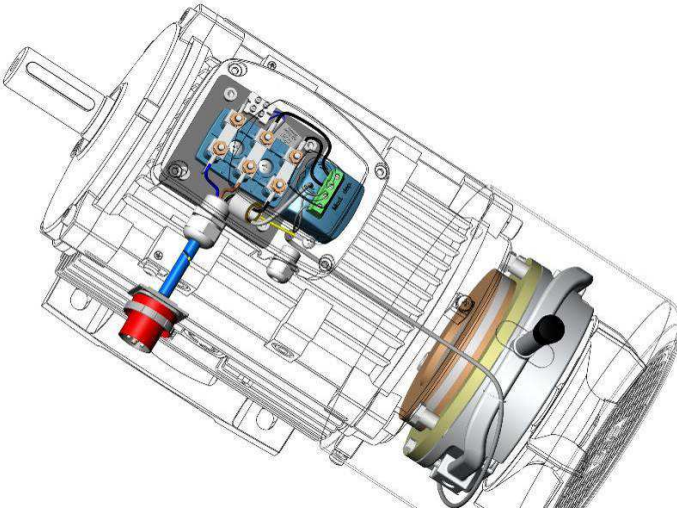



ATDC 112-280  (separate 400Vac/180Vdc rectifier) + inverter (fig. 5°)

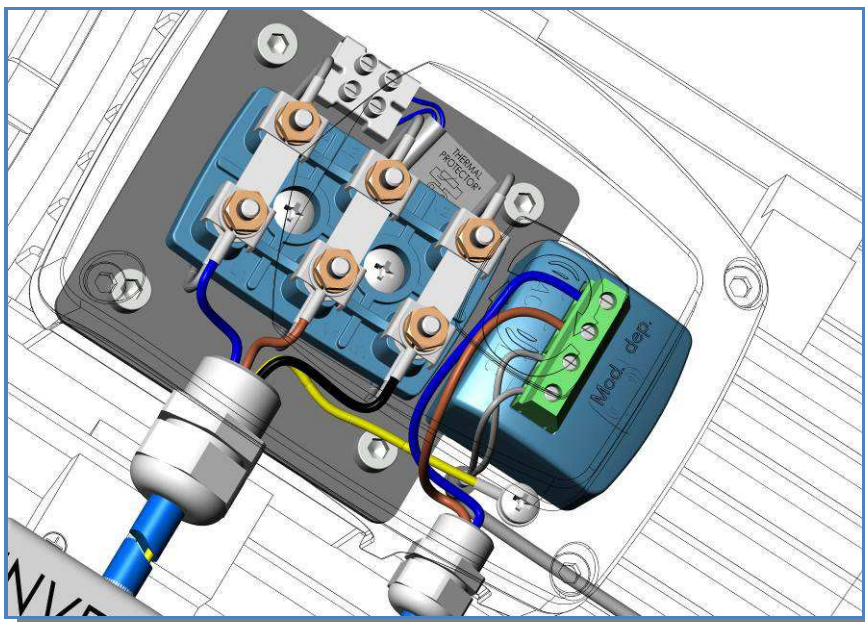
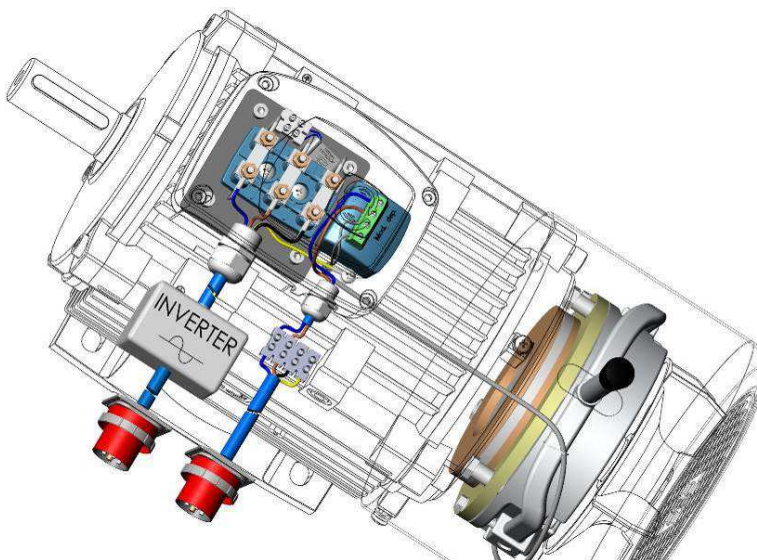





ATDC 63-100  (separate rectifier 230Vac/104Vdc) + inverter (fig. 5b)

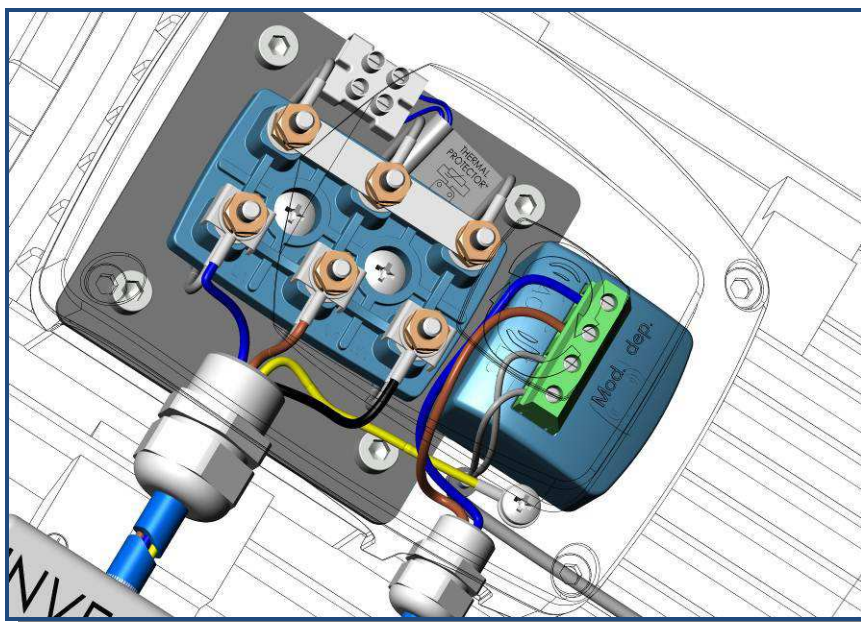
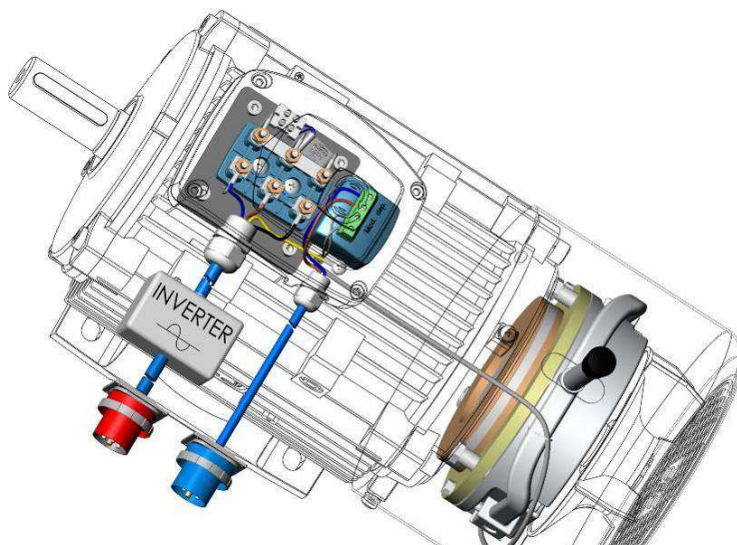



ATDC 112-280  + separate 400Vac/180Vdc rectifier connection (fig. 6)

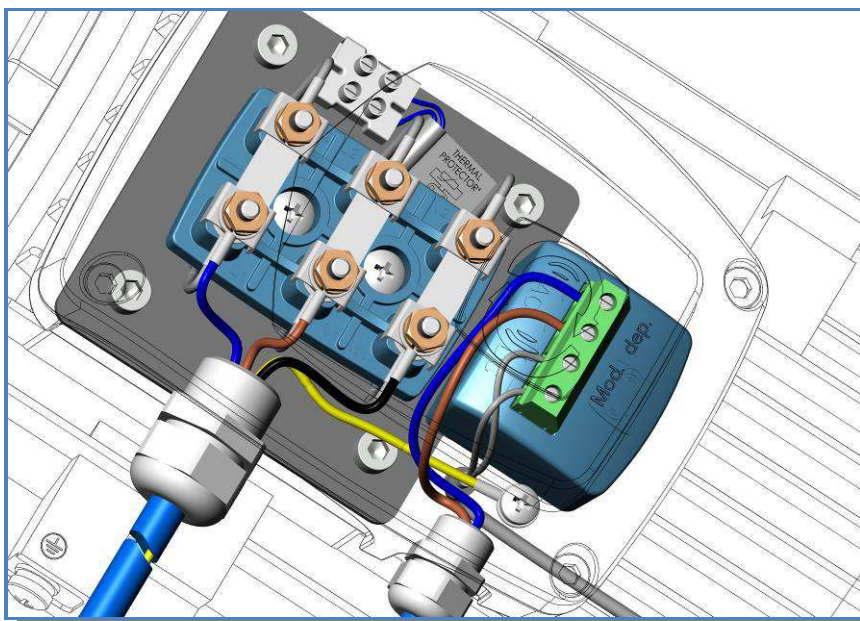
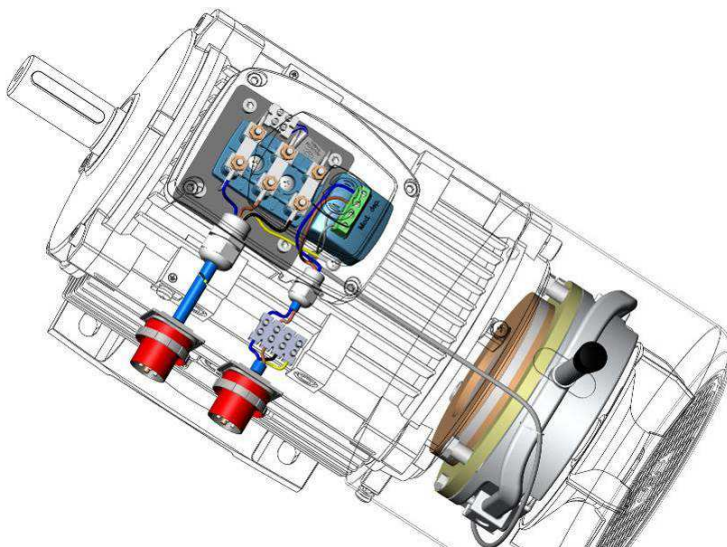



ATDC 63-100  + separate 230/104Vdc rectifier connection (fig. 7)

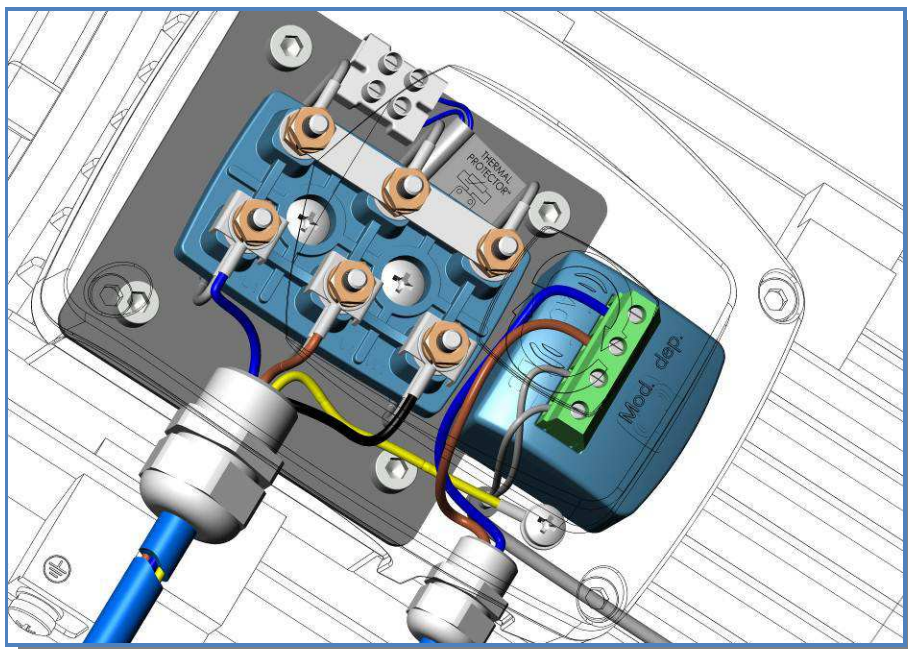
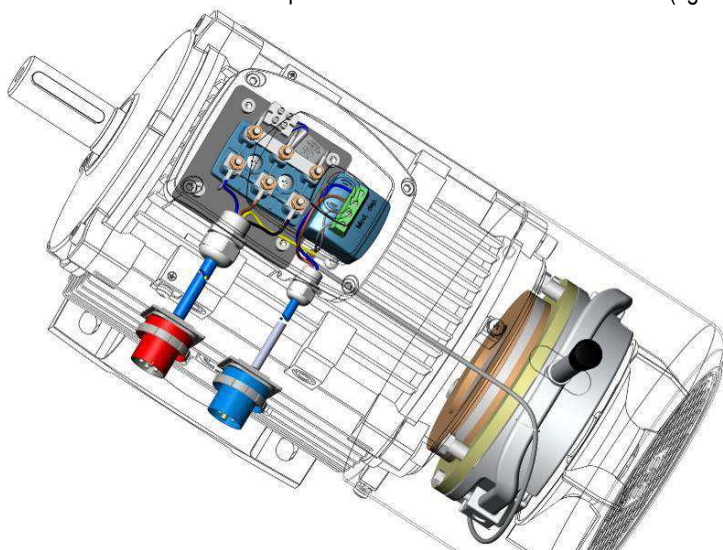





## Sblocco

## Débloccage

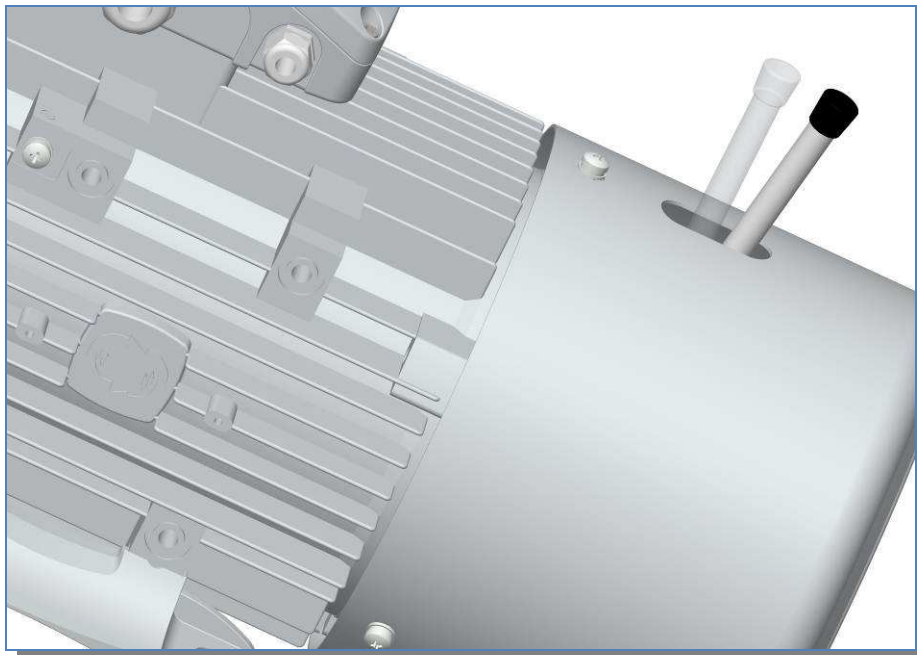

La leva di sblocco è di serie ma, se non desiderata, è come una vite e può essere smontata semplicemente girandola.

I motori con freno tandem ATTD e ATTD24 dalla taglia 180 alla taglia 280 non sono provvisti di leva di sblocco.

Le levier de déblocage est de série, mais si vous n'en avez pas besoin, il est comme une vis et peut être démonté en le tournant simplement.

Les moteurs avec frein tandem ATTD et ATTD24 de la taille 180 à la taille 280 sont équipés de levier de déblocage.



## IP

I freni AT... sono IP55 da un punto di vista elettrico, ma meccanicamente, per un uso esterno (o per raggiungere un IP65), andrebbero protetti dalla ruggine e da effetti di incollatura del disco dovuti all'umidità. In tale caso si consiglia l'uso dei nostri anelli protettivi in gomma

Tale anello previene l'uscita o l'ingresso di polvere, umidità, sporco, fuori o dentro l'area di frenatura.

Esso viene montato inserendolo nell'apposita scanalatura predisposta sul freno. Se il freno non è provvisto di tale scanalatura, va ordinato un freno specificando la richiesta di tale requisito.

Per il mantenimento della coppia frenante nel tempo, è necessario svuotare periodicamente le parti interne all'anello dalla polvere generata dal ferodo del freno

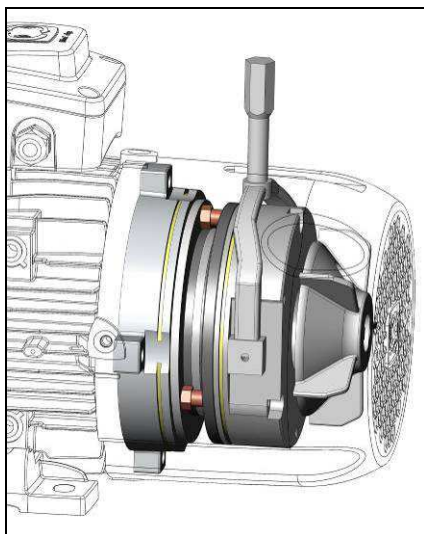

## IP

Les freins AT... sont IP55 du point de vue électrique, mais mécaniquement, pour un usage externe (ou pour le IP65), ils doivent être protégés contre la rouille et les effets de collage du disque dus à l'humidité. Dans ce cas, nous recommandons d'utiliser nos anneaux de protection en caoutchouc. Cet anneau prévient la sortie ou l'entrée de la poussière, de l'humidité, de la saleté hors ou dans la zone de freinage. Il est monté en l'insérant dans la rainure spécifique prévue sur le frein. Si le frein n'est pas pourvu de cette rainure, vous devez commander un frein en spécifiant cette exigence.

Pour l'entretien du couple de freinage au fil du temps, il est nécessaire de vider périodiquement la poussière produite par le ferodo du frein dans les parties se trouvant à l'intérieur de l'anneau..

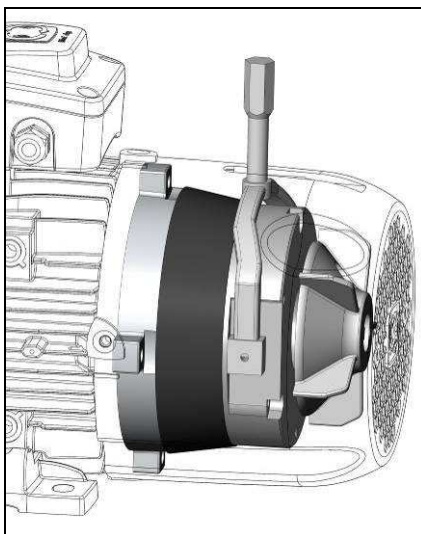





## disco di contatto freno in inox

Su richiesta, laddove l'umidità presente nell'aria può comportare una precoce ossidazione della superficie di contatto tra disco freno e scudo in ghisa del motore, è possibile aggiungere una copertura in inox

## Disque de contactfrein inox

Sur demande, lorsque l'humidité contenue dans l'air peut causer une oxydation précoce de la surface de contact entre le disque de freinage et le bouclier en fonte du moteur, vous pouvez ajouter une couverture en inox

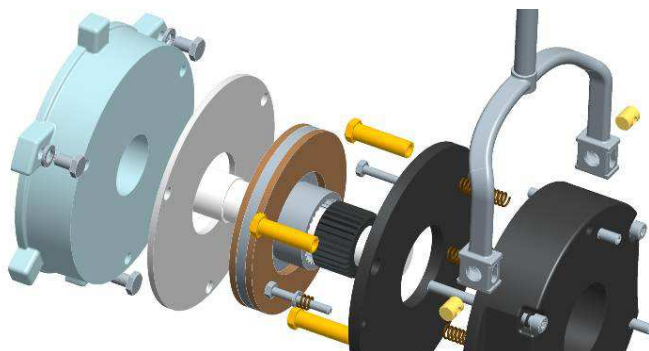

## microinterruttori di rilevamento posizione freno

opzionali

## Microrupteurs de détection position frein

En option

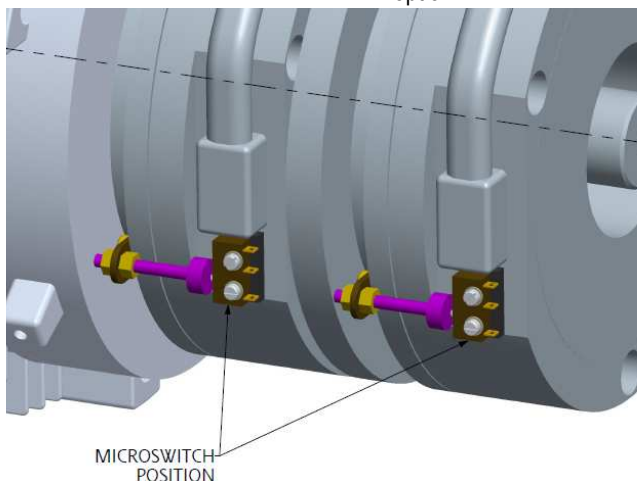



**Conversione motore da standard ad autofrenante ATDC con “kit-ATDC/AT24”**

**From a standard motor to an ATDC brake motor thanks to “kit-ATDC/AT24”**

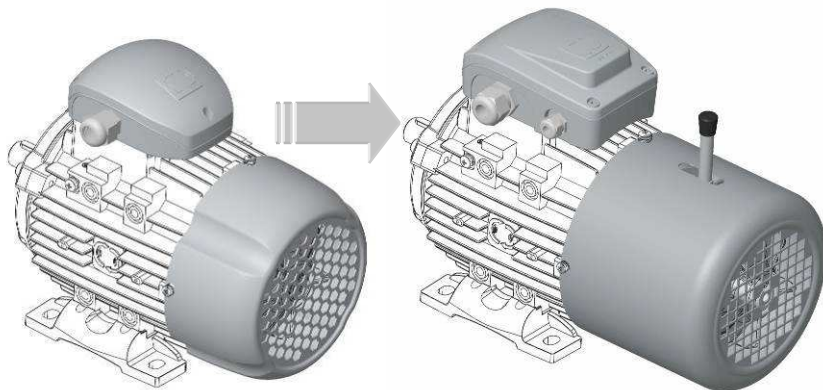

**PARTI KIT-ATDC/AT24 (solo IEC90-160)**

**KIT-ATDC/AT24 PARTS (IEC 90-160 only)**

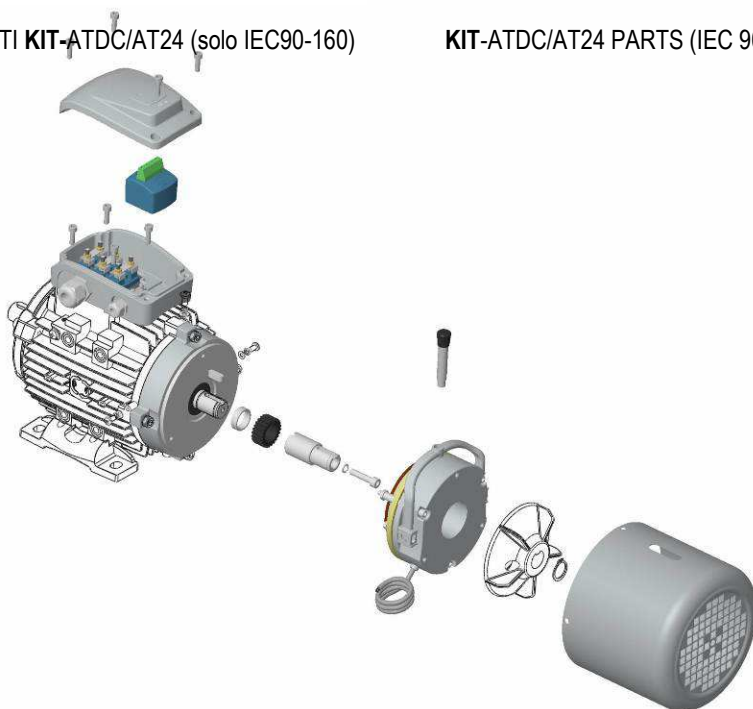



## PASSI

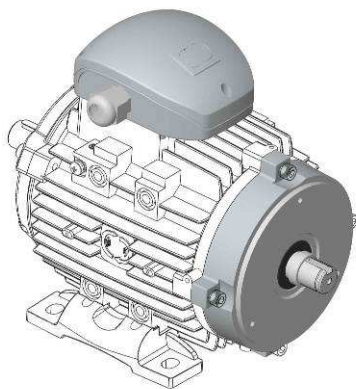
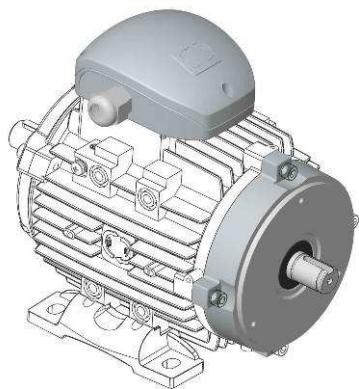
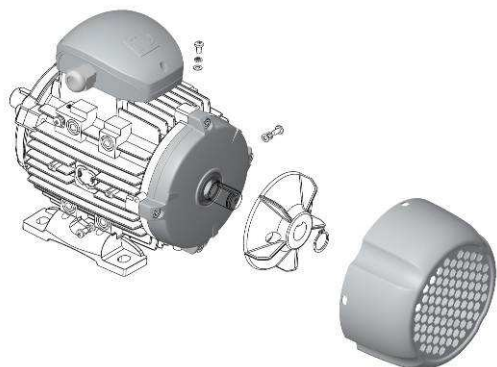

## STEPS

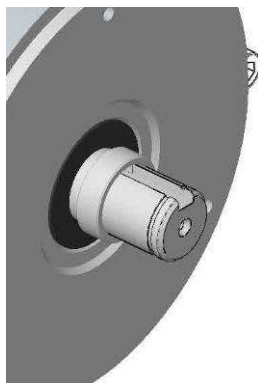
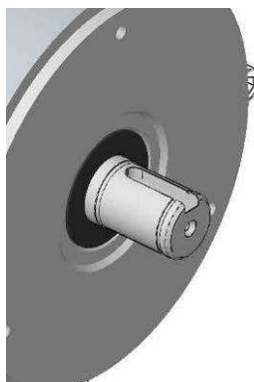
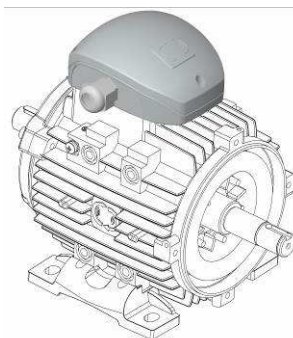

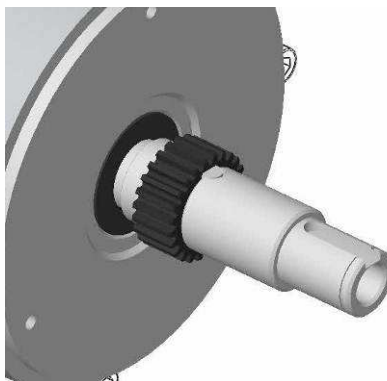
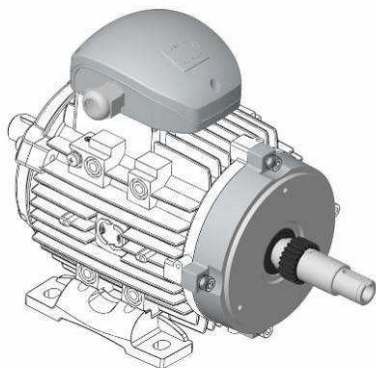
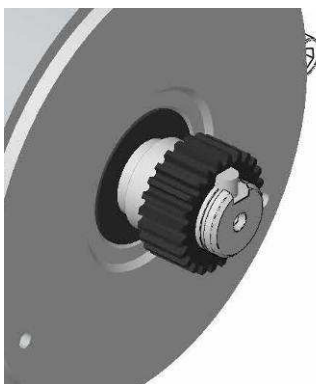
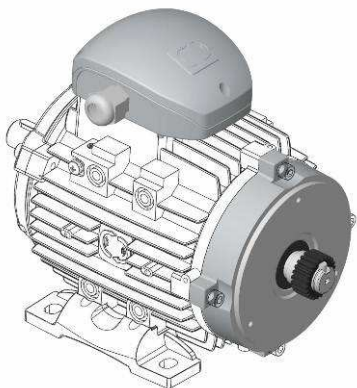
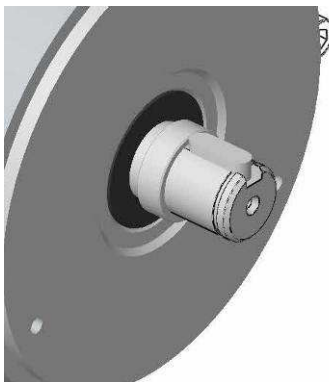
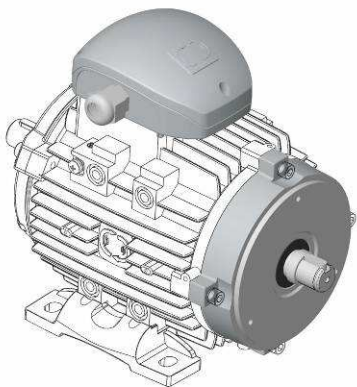



motor type	DH
90	M8X19
100	M10X22
112	M10X22
132	M12X28
160	M16X36

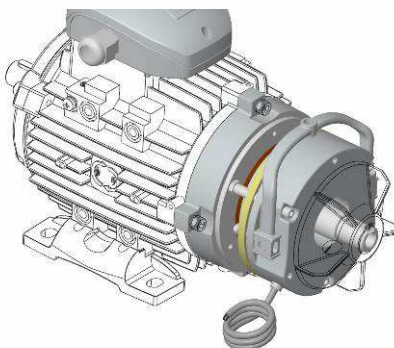
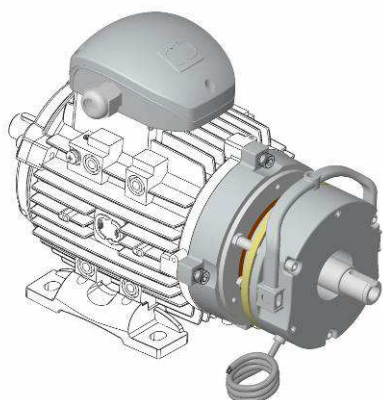
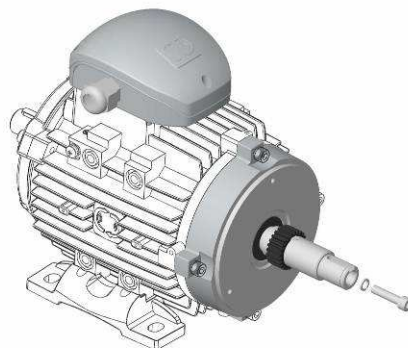



AT24:

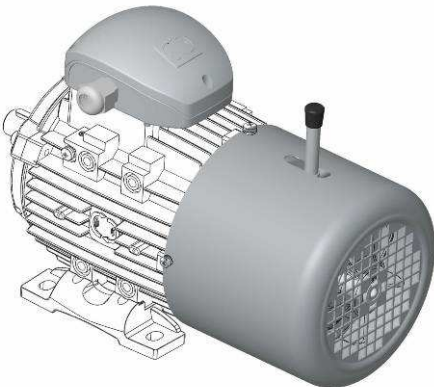
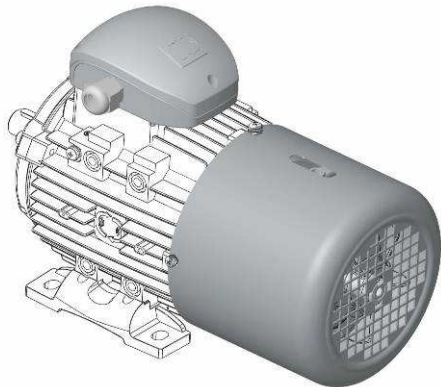
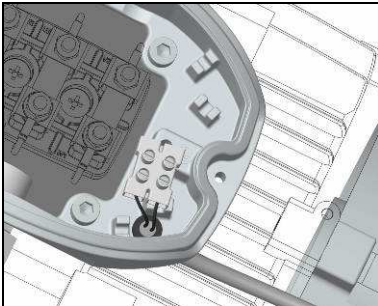
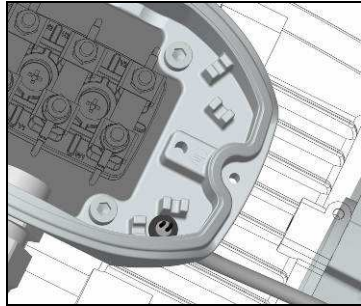
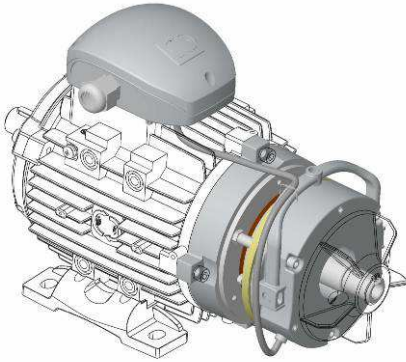





ATDC:

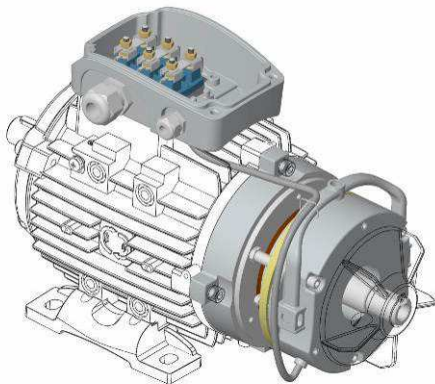
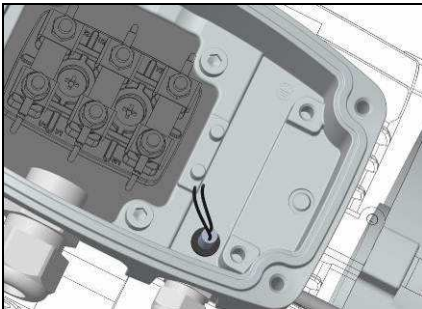
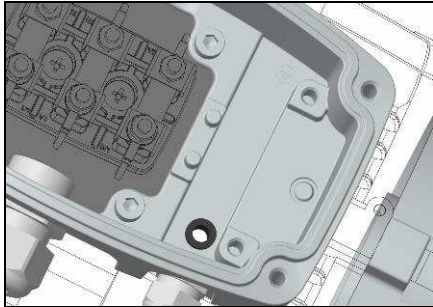
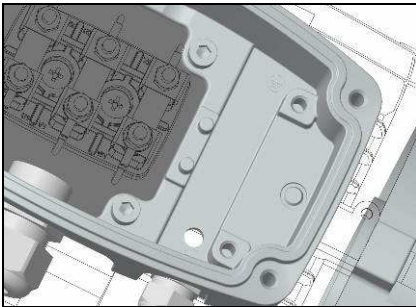
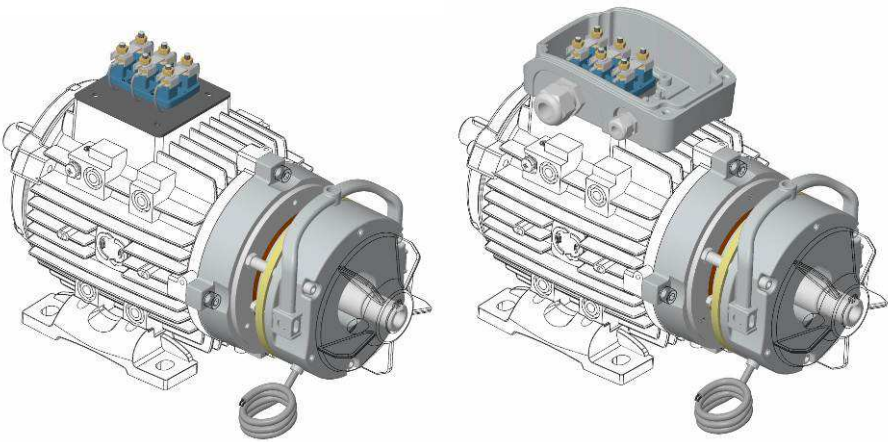



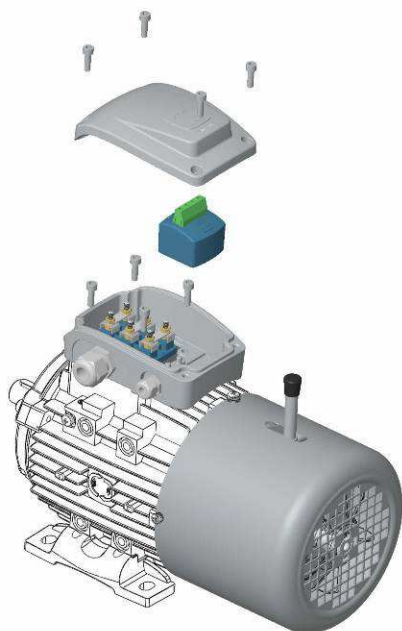

(Fig 1-7)

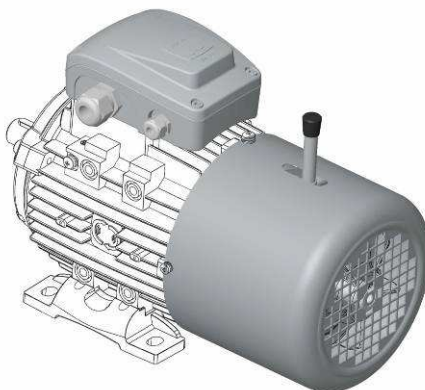
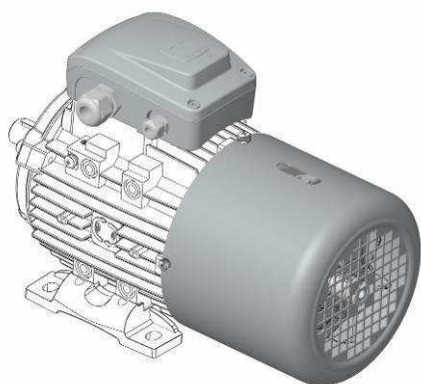
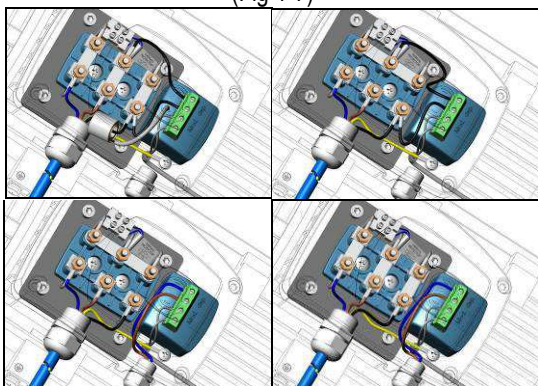



## Servoventilations série SV

Pour les applications avec couple nominal en dessous de la vitesse à 50 Hz du moteur, il est indispensable d'installer une servoventilation. Sur demande, les servoventilations sont disponibles aussi en version monophasé et /ou tension spéciale.

## Motori servoventilati serie SV

Per applicazioni con coppia nominale al di sotto della velocità a 50Hz del motore, si impone il montaggio della servoventilazione adeguata, in quanto sono troppe le variabili in gioco per la determinazione dei vari servizi termici possibili e quindi le temperature raggiunte dai motori

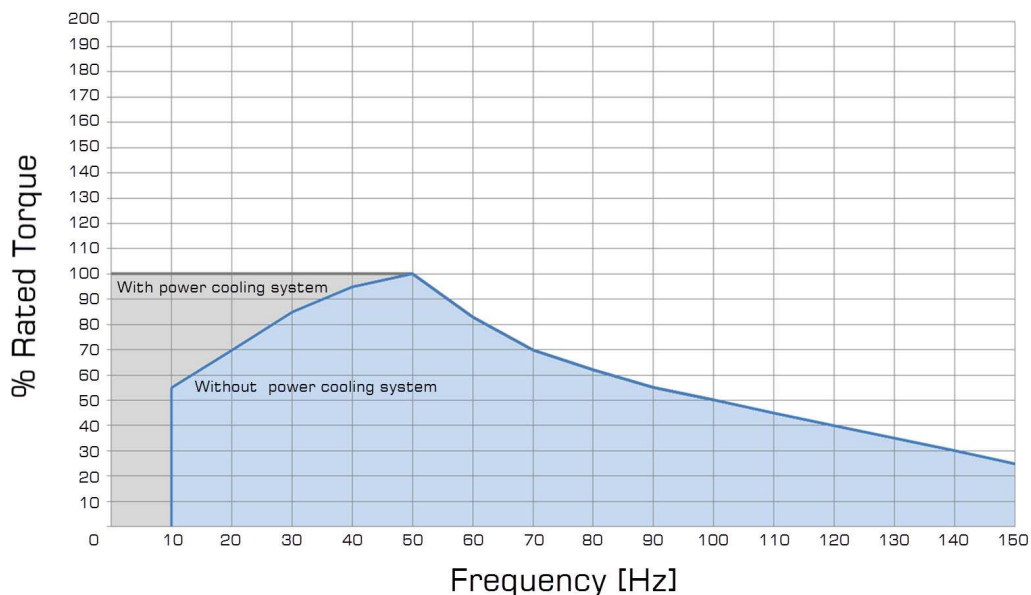



## Encoder

A seconda del tipo di ventilazione, l'encoder può essere montato dalla Motive nei due modi rappresentati di seguito.

Motive raccomanda encoder di propria selezione, le cui caratteristiche vengono segnalate in fase d'ordine.

According to the requested ventilation, encoders can be mounted by Motive in the 2 following ways.

Motive recommends the encoder types that it selected. Their features can be communicated upon request.

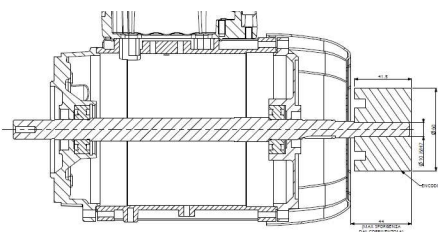
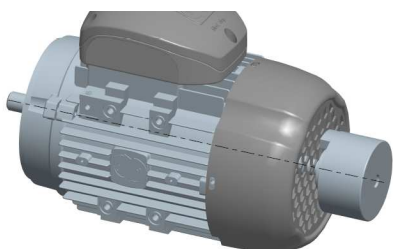
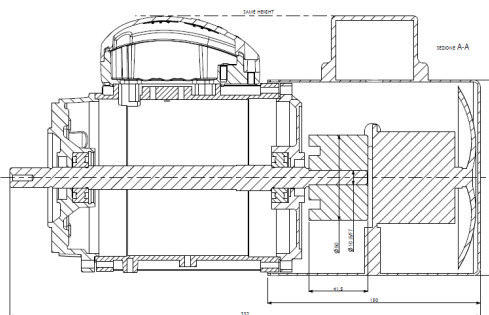
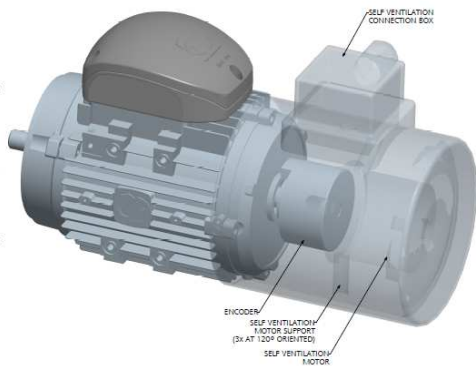



## Trasporto, conservazione, uso e manutenzione

La Motive srl fornisce i motori in imballi idonei ad ogni tipo di trasporto

Il motore deve essere conservato in ambiente coperto, asciutto, privo di vibrazioni e polvere, a temperatura superiore a  $-15^{\circ}\text{C}$ .

Le parti esposte, come flange ed estremità dell'albero, devono essere protette con lubrificante. E' opportuno ruotare periodicamente l'albero per assicurare nel tempo la completa lubrificazione dei cuscinetti.

Il motore deve essere installato e utilizzato da personale qualificato e a conoscenza dei requisiti di sicurezza. Anche le operazioni di installazione devono avvenire in ambiente asciutto e protetto dagli agenti atmosferici. La temperatura e l'umidità di esercizio deve essere compresa nei limiti descritti nel precedente paragrafo "condizioni di funzionamento". Lo smontaggio e l'assemblaggio del motore devono essere effettuati da personale qualificato. Qualsiasi intervento sulla scatola coprimorsettiera deve essere effettuato solo dopo aver interrotto l'alimentazione.

Eventuali ispezioni devono essere eseguite con l'uso di appositi strumenti (estrattori), evitando l'uso di attrezzi che possano arrecare danni al motore, quali martelli o attrezzi ad impatto. E' opportuno eseguire ispezioni periodiche, per garantire le migliori condizioni di lavoro, effettuando: pulizia del motore, verifica della ventilazione, identificazione di eventuali rumori anomali e vibrazioni. In questo caso controllare i cuscinetti (vedi la tabella nr 1) e, se necessario, sostituirli, come pure il paraolio.

Verificare infine il corretto fissaggio del motore sulla flangia o sui piedini.

I motori non devono essere immagazzinati in ambienti con rischio di esplosione.

Prima di utilizzare il motore, pulire le connessioni di terra e l'involucro da eventuali residui di polveri e/o tracce di ossidazione.



### Raccomandazioni speciali per motori atex

Tutte le operazioni di verifica e manutenzione dei motori devono essere eseguite in modo da rispettare la Norma EN 60079-17. In particolar modo bisogna prestare attenzione che tutte le viterie devono essere serrate a fondo.

La sostituzione di alcune parti soggette ad usura (es. guarnizioni di tenuta sull'albero, cuscinetti) deve essere effettuata con componenti identici a quelli forniti dal costruttore al fine di garantirne il mantenimento dei requisiti di sicurezza e del grado di protezione.

La superficie dei giunti (es. accoppiamento carcassa/scudi; giunti passaggio d'albero) **NON DEVONO ESSERE NE' LAVORATE NE' VERNICIATE**. Tali superfici devono essere tenute pulite



e, contro la corrosione o l'ingresso di acqua, deve essere mantenuto sulle stesse un velo di grasso silconico

Le riparazioni dei motori ATEX devono essere eseguite secondo quanto prescritto nella norma IEC 79-19, e possono essere svolte "solamente dal costruttore" o da officine autorizzate dal costruttore stesso

## Avvertenze per l'installazione

Per l'installazione del motore, è consigliabile attenersi alle seguenti indicazioni:

- verificare che non vi siano stati danni durante il trasporto;
- pulire adeguatamente i componenti dell'impianto da residui dell'imballaggio e da eventuali prodotti protettivi;
- verificare che il valore della tensione di alimentazione stampigliata sulla targhetta del motore, coincida con la tensione di rete;
- la verniciatura non deve interessare le superfici di contatto dei collegamenti equipotenziali e la targhetta di identificazione;
- installare il motore su una superficie piana;
- accertarsi che i piedini o la flangia siano ben serrati e che, nel caso di giunto diretto, il motore sia perfettamente allineato;
- far ruotare manualmente l'albero per verificare l'assenza di rumori da strisciamento;
- verificare il senso di rotazione con trasmissione disinnestata;
- calettare (estrarre) gli elementi condotti (es. puleggia per trasmissione a cinghia, giunto, ecc.), solo mediante dispositivi appositi (calettamento a caldo). Evitare tensioni non consentite sulla puleggia (rif. catalogo par. distinta tecnica);
- non ostacolare la ventilazione. L'aria scaricata, compresa quella proveniente da altri gruppi, non deve essere subito riaspirata;
- verificare la corretta messa a terra del motore



### Messa a terra (DELPHI 3PH)

La messa a terra può essere fatta sia all'interno del coprimorsettiera (fig.1)

che utilizzando l'apposito fissaggio sulla carcassa (fig.2). Quest'ultimo tipo di connessione può essere richiesto nel caso in cui il cavo di connessione alla morsettiera manchi del 4° filo per la terra, oppure perché prescritto da apposite normative (es. ATEX), o per collegare in serie la messa a terra di più motori da carcassa a carcassa, o in prodotti customizzati senza morsettiera.

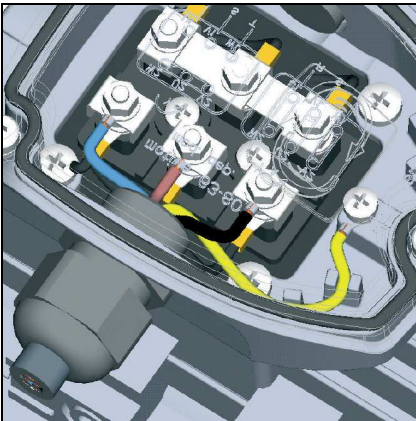

Fig.1

### Earth connection (DELPHI 3PH)

Earth connection can be done either inside the terminal box (Fig.1) or by using the screw on the housing (Fig.2). This last connection can be requested when the cable going into the terminal box is a 3 wires cable, without the earth one, or when prescribed by some norms (like ATEX), or to connect in series several motors earth by connecting their frames each other, or in customized motors without terminal block and terminal box.

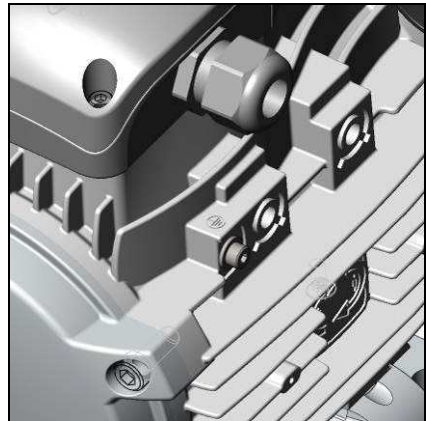

Fig.2



## Transport, conservation, utilise et maintenance

Motive livre les moteurs dans packagings convenables pour n'importe quelle sorte de transport.

Le moteur doit être conservé dans un ambiant sec et protégé par les agents atmosphériques, sans la présence de vibrations ou de poussière, à une température pas inférieure de  $-15^{\circ}\text{C}$ .

Les parties exposées, comme les brides et les arbres, doivent être protégées par du lubrifiant. Il est opportun de faire tourner périodiquement l'arbre pour garantir une lubrification de longue date des roulements.

Seul un personnel qualifié est autorisé à mettre l'appareil en marche et à en assurer le fonctionnement. Dans l'esprit des conseils au niveau des techniques de sécurité, le personnel qualifié est composé des personnes autorisées à mettre en service, à mettre à la terre et à marquer les appareils, les systèmes et les circuits électriques.

L'appareil ne peut être utilisé que dans les cas d'utilisation prévus au catalogue et dans les instructions de projection et ce, uniquement en relation avec les appareils et composants étrangers conseillés ou agréés par Motive. L'exploitation sans problèmes et sûre du produit sous-entend un transport approprié, un stockage, une installation et un montage appropriés préalables, ainsi qu'un maniement et un maintien en état scrupuleux.

L'installation doit arriver dans le climat sec et protégé par les agents atmosphériques. La température du travail et l'humidité doivent être dans les limites décrites dans le paragraphe précédent "conditions de fonctionnement". Le démontage et montage peuvent être faits par un personnel qualifié. N'importe quelle intervention sur la boîte des bornes peut être faite seulement après avoir débranché l'alimentation électrique.

Les éventuelles inspections doivent être faites avec les instruments nécessaires, en évitant des moyens qui pourraient nuire au moteur. Il est opportun de faire des inspections périodiques, garantir les meilleures conditions de travail et la réalisation : le nettoyage du moteur, la vérification de la ventilation, et l'identification de bruit ou vibration anormales. Dans ce dernier cas, vérifiez les roulements (voir l'étiquette 1) et, si nécessaire, substituez-les, aussi bien que les bagues à lèvres.

Vérifiez la fixation correcte du moteur sur la bride ou sur les pieds.





### **Recommended precautions for ATEX motors**

All maintenance and control operations on ATEX motors must be done respecting the norm EN 60079-17. Pay attention that all screws are closed tightly.

The replacement of parts subject to wear, (like bearings and oil seals, must be done using only original spare parts in order to preserve the safety requirements and protection degree.

The joints surfaces (for instance between housing and shields, shaft) must not be neither machined nor painted. Such surfaces must be kept clean and, against corrosion and water entry, you must keep on the same a layer of silicon grease.

Repair of ATEX motors must be done respecting the norm IEC 79-19, and they can be done only by the manufacturer or by trained and authorized external workshops.



## Installation precautions

For the installation of the motor please consider the following:

- make sure that no damages have occurred during transportation;
- carefully remove the components of the plant from the wrapping material and any other protective devices;
- make sure that the value of the voltage on the rating plate is the same as the voltage of mains;
- the surfaces in contact with the electric bonding and the rating plate must not be varnished;
- set the motor on a flat surface;
- make sure that the bearings or the flange are well fixed and that in case of direct joint the motor is perfectly aligned;
- make the rotor rotate manually in order to verify the absence of any dragging;
- verify the rotation sense removing the joint;
- key (extract) the output components (i.e. joint, belt pulley, etc.) only using apt devices (shrinking-on). Avoid not allowed tension on the pulley (ref. catalogue par. technical sheet);
- in the models in which the shaft is with the end downwards, use the protective cover. If the end of the shaft is upwards, use a cover preventing any penetration of external parts into the fan;
- do not hinder ventilation. The discharged air, together with the air coming from other groups, must not be immediately re-aspirated;
- verify the correct grounding of the motor



## Lubrificazione cuscinetti (DELPHI 3PH)

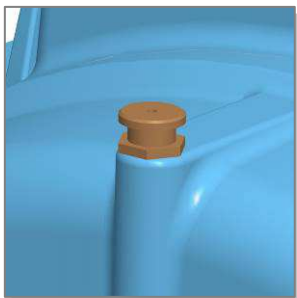

I motori con cuscinetti stagni autolubrificati a vita non richiedono lubrificazione. La durata dei cuscinetti varia dai 3 ai 5 anni a seconda dei carichi assiali e radiali applicati all'albero e secondo le condizioni ambientali di impiego del motore. I motori previsti con il dispositivo di lubrificazione dei cuscinetti devono essere lubrificati con il motore in moto secondo gli intervalli di lubrificazione e la quantità indicati nella tabella 2.



Sui cuscinetti speciali a rulli "NU" o "NJ" e a



contatto obliquo "7.." dimezzano.

fuori standard, gli intervalli di lubrificazione della tabella 2 si

Gli intervalli di lubrificazione si dimezzano anche per motori alimentati da inverter " causa vetrificazione del grasso per passaggio corrente tra rotore e statore. Per questo motivo, sono raccomandati per questi motori alimentati da inverter i cuscinetti isolati (esecuzione speciale), soprattutto su motori con potenza  $\geq 110\text{kW}$ .



Si può usare grasso al litio o polyurea con olio di base minerale adatto ad una temperatura max di esercizio di almeno  $190^{\circ}\text{C}$ . Comunque, motive raccomanda Mobil Polyrex EM or Mobil Mobilith SHC per la massima durata.

## Lubrification des roulements (DELPHI 3PH)

Les moteurs 56-160 adoptent roulements fermés ZZ ou RS roulements prélubrifiés à vie, et n'exigent pas une lubrification. La vie des roulements varie de 3 jusqu'à 5 ans selon les charges axiales et radiales qui sont appliquées sur l'arbre et aux conditions de l'environnement dans lequel le moteur est utilisé.

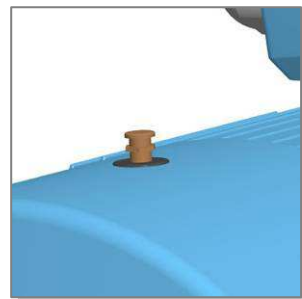



Les graisseurs sont de série à partir du type 180. Ces moteurs sont livrés avec de la graisse dans les roulements. Sur demande, ils peuvent être fournis avec de la graisse pour fonctionnement à des températures spéciales.

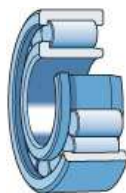

Les roulements dehors du standard à rouleau "NU" ou avec contact angulaire



"7 ..", nécessitent intervalles de graissage réduites de moitié en comparaison avec le tableau 2.

Les intervalles de graissage sont réduits de moitié aussi pour les moteurs alimentés par convertisseurs de fréquence pour la vitrification de la graisse due au passage d'arcs de courant entre le rotor et le stator. Pour cette raison, ils sont recommandés pour ces moteurs alimentés par variateurs de vitesse les roulements isolés (spéciales), en particulier sur les moteurs avec puissance  $\geq 110$  kW



En peut utiliser graisse lithium ou polyurea avec base de huile minérale de pétrole convenable pour une température max de travail au moins de 190°C. De toute façon, nous recommandons Mobil Polyrex EM ou Mobil Mobilith SHC pour la max dureté

Tab. 2

motore moteur	Quantità grasso (g)		Intervalli di lubrificazione in ore operative			
	Quantité de graisse (g)		Intervalles de lubrification en heures de travail			
grandezza type	2 poli	4-6-8 pôli	2 Poli	4 Poli	6 Poli	8 Poli
	2 pôles	4-6-8 pôles	2 pôles	4 pôles	6 pôles	8 pôles
<b>180-200*</b>	25		3800	9300	12400	15200
<b>225*</b>	25		3800	8900	12200	14800
<b>250*</b>	30		3100	4100	5900	6900
<b>280*</b>	28	36	800	3900	5600	6700
<b>315</b>	36	45	800	2300	4100	5100
<b>355</b>	45	60	700	2000	4000	4500



#### \*Lubrificazione cuscinetti motori 180-280

I motori dalla taglia 180 fino alla taglia 280, dal 2017 sono provvisti di cuscinetti chiusi autolubrificati e, quindi, esenti da manutenzione x ingrassaggio periodico

NB: durante gli anni 2016-2017, i motori 180-280 potrebbero essere dotati di ingrassatori e cuscinetti aperti, per i tempi di aggiornamento prodotto e per lo smaltimento delle scorte di magazzino.

#### \*Graissage roulements moteurs 180-280

De la taille 160 à 280, à partir de 2017 nous montons des roulements autolubrifiants ZZ et, ensuite, exemptés de maintenance pour re-graissage

NB: Durant les années 2016-2017, les moteurs 180-280 peuvent être encore dotés de graisseurs et de roulements ouverts, pour le temps de mettre à jour la production





# Lista ricambi - Liste des composants

DELPHI (3PH)

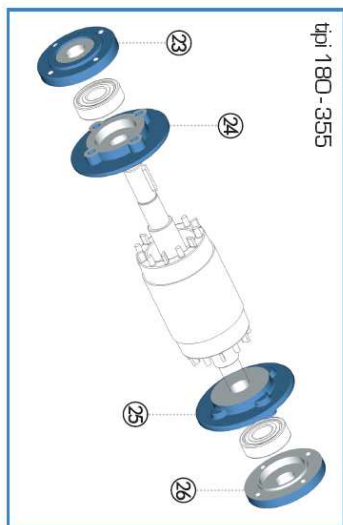
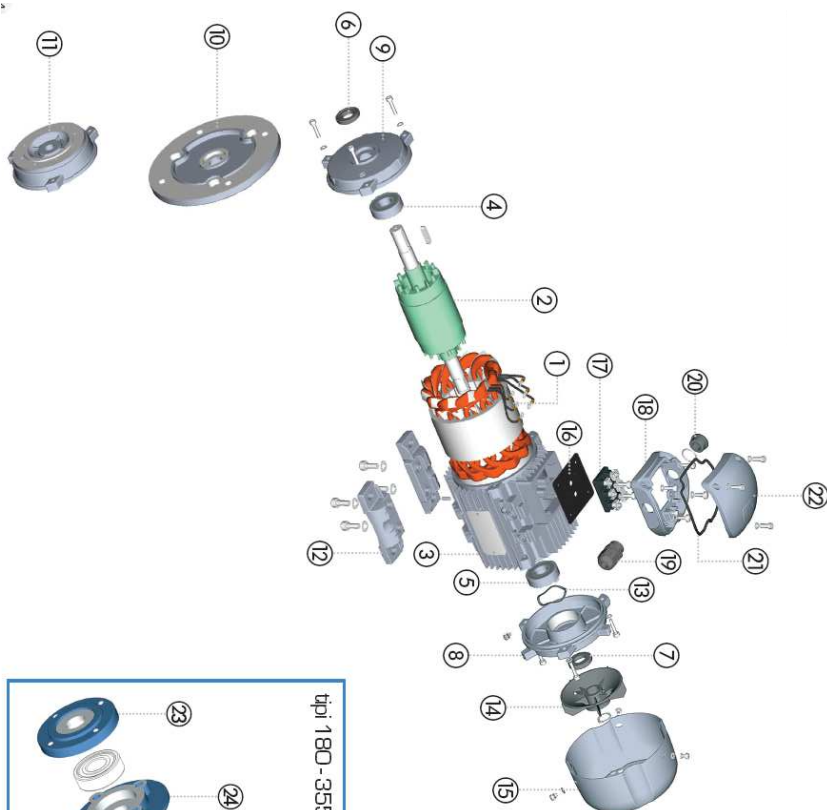

N°	CODICE
1	3PNSTA
2	3PNFOT
3	3PNFEA
4	3PNFBE
5	3PNFBE
6	3PNFOS
7	3PNBOS
8	3PNBSH
9	3PNBOS
10	3PNBOS
11	3PNB1/4
12	3PNFEE
13	3PNMAV

N°	CODICE
14	3PNFAN
15	3PNFCV
16	3PNLDB
17	3PNTER
18	3PNBDB
19	3PNAMP
20	3PNCAP
21	3PNSCB
22	3PNDCB
23	3PNFCB
24	3PNHFB
25	3PNBFB
26	3PNBDB





### DELPHI (3PH)

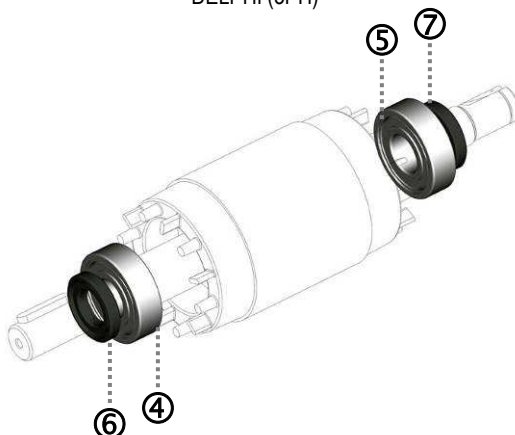

Tipo	Poli	Paraolio - BAGUE À LÈVRE		Cuscinetti - ROULEMENTS		
Type	poles	⑥	⑦	④	⑤	
					standard	AT...
56	2 - 8	12x25x7	12x25x7	6201 ZZ-C3	6201 ZZ-C3	=
63	2 - 8	12x25x7	12x25x7	6201 ZZ-C3	6201 ZZ-C3	=
71	2 - 8	15x30x7	15x30x7	6202 ZZ-C3	6202 ZZ-C3	=
80	2 - 8	20x35x7	20x35x7	6204 ZZ-C3	6204 ZZ-C3	=
90	2 - 8	25x40x7	25x40x7	6205 ZZ-C3	6205 ZZ-C3	=
100	2 - 8	30x47x7	30x47x7	6206 ZZ-C3	6206 ZZ-C3	=
112	2 - 8	30x47x7	30x47x7	6206 ZZ-C3	6206 ZZ-C3	6306 ZZ-C3
132	2 - 8	40x62x8	40x62x8	6208 ZZ-C3	6208 ZZ-C3	=
160	2 - 8	45x62x8	45x62x8	6309 ZZ-C3	6309 ZZ-C3	=
180	2 - 8	55x72x8	55x72x8	6311 ZZ-C3	6311 ZZ-C3	=
200	2 - 8	60x80x8	60x80x8	6312 ZZ-C3	6312 ZZ-C3	=
225	2 - 8	65x80x10	65x80x10	6313 ZZ-C3	6313 ZZ-C3	=
250	2 - 8	70x90x10	70x90x10	6314 ZZ-C3	6314 ZZ-C3	=
280	2	70x90x10	70x90x10	6314 ZZ-C3	6314 ZZ-C3	=
280	4 - 8	85x100x12	80x100x12	6317 ZZ-C3	6317 ZZ-C3	=
315	2	85x110x12	85x110x12	6317-C3	6317-C3	
315	4 - 8	95x120x12	95x120x12	NU 319-C3	6319-C3	
355	2	95x120x12	95x120x12	6319-C3	6319-C3	
355	4 - 8	110x130x12	110x130x12	NU 322-C3	6322-C3	
400	4 - 8	130x160x12	130x160x12	NU 326-C3	6326-C3	



## MONO (1PH)

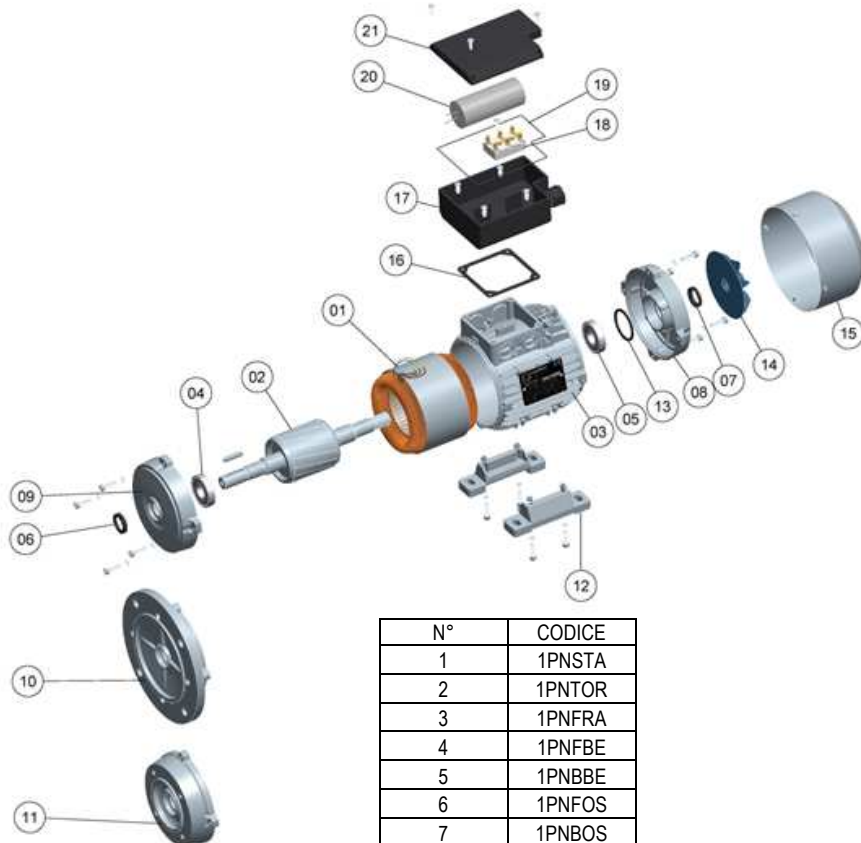

N°	CODICE
1	1PNSTA
2	1PNTOR
3	1PNFRA
4	1PNFBE
5	1PNBBE
6	1PNFOS
7	1PNBOS
8	1PNBSH
9	1PNB03
10	1PNB05
11	1PNB14
12	1PNFEE
13	1PNWAV
14	1PNFAN
15	1PNFCV
16	1PNUCB
17	1PNBCB
18	1PNTER
19	1PNSCB
20	1PNCON
21	1PNCCB



## MONO (1PH)

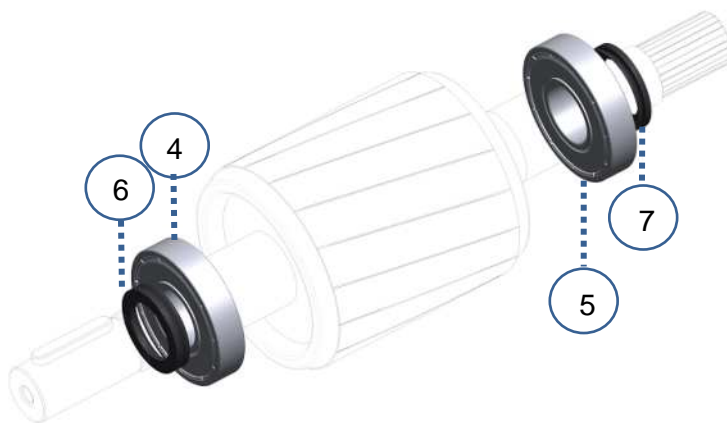

Tipo	Poli	V Ring		Cuscinetti - Bearings	
Type	poles	⑥	⑦	④	⑤
63	2-4	VR14	VR14	6202ZZ	6202ZZ
71	2-4	VR14	VR14	6202ZZ	6202ZZ
80	2-4	VR19	VR19	6204ZZ	6204ZZ
90	2-4	VR24	VR24	6205ZZ	6205ZZ
100	2-4	VR28	VR28	6206ZZ	6206ZZ
112	2-4	VR28	VR28	6306ZZ	6306ZZ



## carichi massimi – max admitted loads

### DELPHI (3PH)

	Fr [N] standard				Fa1 / Fa2 [N] standard				Fa1 / Fa2 [N] special option			
	3000rpm	1500rpm	1000rpm	750rpm	3000rpm	1500rpm	1000rpm	750rpm	3000rpm	1500rpm	1000rpm	750rpm
56	275	360			120	160			380	500		
63	300	375			120	160			380	500		
71	330	410	480	500	200	250	300	320	640	800	960	1000
80	550	690	800	900	280	340	400	460	890	1160	1370	1440
90	800	770	880	980	340	460	570	650	1480	2000	2480	2080
100	890	1100	1250	1400	480	590	750	890	1960	2410	3070	2900
112	1000	1200	1400	1500	480	590	750	850	1960	2410	3070	3700
132	1350	1700	1980	2200	600	1000	1300	1500	1110	1840	2390	6130
160	2300	2700	3000	3200	1380	1500	1900	2200	1990	2290	2890	8980
180	3000	4000	4600	5300	2400	2700	3000	3000	3580	4000	4450	6070
200	3880	4880	5500	5500	3000	3900	4800	4880	3700	4810	5820	7320
225	4200	5200	6000	6000	3600	4900	5700	5700	5400	7300	8550	8450
250	4800	6000	6000	6000	4100	5900	6500	6500	5830	7950	9390	8010
280	4800	7800	6900	6900	4200	6900	6800	6800	6070	9830	9630	10200
315	5800	15000	15000	17500	4600	7000	7000	7000	6580	10000	10000	10120
355	7700	19000	19000	19000	5800	7200	7200	7200	7740	9800	9800	10400
400	9000	20500	20500		7300	12500	14800		9960	17050	19910	

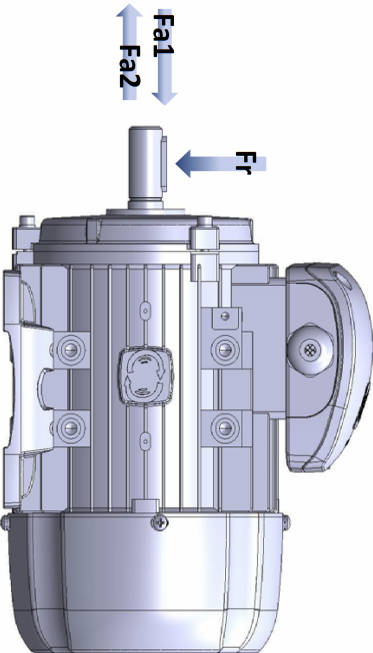



MONO (1PH)

	Fr [N]		Fa1 [N]		Fa2 [N]	
	3000rpm	1500rpm	3000rpm	1500rpm	3000rpm	1500rpm
<b>56</b>	275	360	120	160	120	160
<b>63</b>	300	375	120	160	120	160
<b>71</b>	330	410	200	250	200	250
<b>80</b>	550	690	260	340	260	340
<b>90</b>	600	770	340	460	340	460
<b>100</b>	880	1100	480	590	480	590
<b>112</b>	1000	1200	480	700	480	700

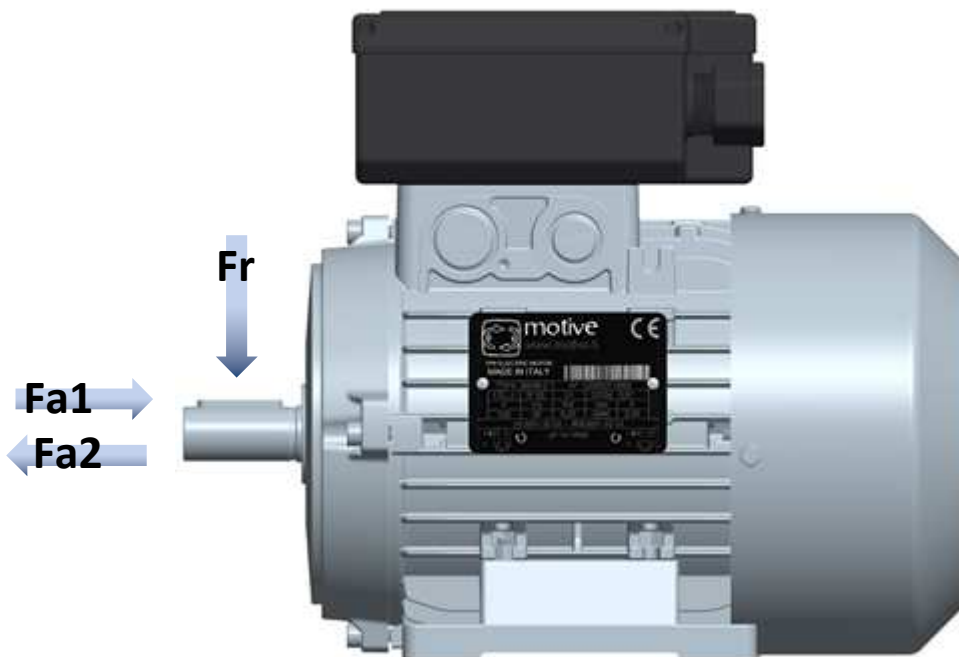



Motive s.r.l.  
Via Le Ghiselle, 20  
25014 Castenedolo (BS)  
Tel.: +39 030 2677087  
Fax: +39 030 2677125  
motive@motive.it



## Dichiarazione di conformità

La ditta Motive s.r.l. con sede in Castenedolo (BS) - Italia

dichiara, sotto la sua esclusiva responsabilità,

che la sua intera gamma di **motori elettrici asincroni trifase IEC 56-400 serie DELPHI e DELFIRE**

è costruita e collaudata in conformità con la seguente normativa internazionale (ult. ediz.)

- EN60034-1** Macchine elettriche rotanti - Parte 1: Caratteristiche nominali e di funzionamento
- EN60034-6** Macchine elettriche rotanti - Parte 6: Sistemi di raffreddamento
- EN60034-7** Macchine elettriche rotanti - Parte 7: Classificazione delle forme costruttive e dei tipi di installazione nonché posizione delle morsettiere (Codice IM)
- EN60034-8** Macchine elettriche rotanti - parte 8: Marcatura dei terminali e senso di rotazione
- EN60034-25** Macchine elettriche rotanti-Parte 25: Guida per la progettazione e le prestazioni dei motori in corrente alternata specificamente progettati per l'alimentazione da convertitori
- EN60034-2-1** Macchine elettriche rotanti: Metodi di prova per determinare le perdite e l'efficienza
- EN60034-30-1** Macchine elettriche rotanti-Parte 30: Classi di rendimento dei motori a corrente alternata alimentati dalla rete (Codice IE)
- EN50347** Motori asincroni trifase di uso generale con dimensioni e potenze normalizzate - Grandezze da 56 a 315 e numeri di flangia da 65 a 740
- EN61000-6-4** Compatibilità elettromagnetica (EMC): Parte 6-4: Norme generiche - Emissione per gli ambienti industriali
- IEC 72-1** Dimensions and output series for rotating electrical machines Part 1: Frame numbers 56 to 400 and flange numbers 55 to 1080

come richiesto dalle Direttive

**Bassa Tensione (LVD) 2014/35/EU,**  
**EMC Compatibilità Elettromagnetica (EMC) 2014/30/EU**  
**ErP progettazione ecocompatibile dei prodotti (ErP) 2019/1781/EU**

Il motore non deve funzionare finché la macchina ove viene assemblato viene dichiarata conforme alla **Direttiva Macchine 2006/42/EU**

Il Rappresentante Legale: Giorgio Bosio

N. REA 422301  
Cod. Fisc. e P. IVA 03580280174





Motive s.r.l.  
Via Le Ghiselle, 20  
25014 Castenedolo (BS)  
Tel.: +39 030 2677087  
Fax: +39 030 2677125  
motive@motive.it



## DECLARATION DE CONFORMITE



La société Motive S.r.l. sise à Castenedolo - BRESCIA (Italie)

Déclare sous son entière responsabilité, que toute sa gamme de

**moteurs asynchrones électriques triphasés série « DELPHI » et « DELFIRE »**

est réalisée et testé conformément à la normative internationale

- EN60034-1** Rotating Electrical Machines - Part 1: Rating and performance
- EN60034-6** Rotating Electrical Machines - Part 6: Methods of cooling (IC code)
- EN60034-7** Rotating Electrical Machines - Part 7: Classification of Types of Construction, Mounting Arrangements and Terminal Box Position (IM Code)
- EN60034-8** Rotating electrical machines – Part 8: Terminal markings and direction of rotation
- EN60034-25** Rotating electrical machines - Part 25: Guidance for the design and performance of a.c. motors specifically designed for converter supply
- EN60034-2-1** Rotating electrical machines. Standard methods for determining losses and efficiency from tests
- EN60034-30-1** Rotating electrical machines - Part 30: Efficiency classes of single-speed, three-phase, cage-induction motors
- EN50347** General purpose three-phase induction motors having standard dimensions and outputs. Frame numbers 56 to 315 and flange numbers 65 to 740
- EN61000-6-4** Electromagnetic compatibility (EMC) - Part 6: Generic standards - Section 4: Emission standard for industrial environments
- IEC 72-1** Dimensions and output series for rotating electrical machines Part 1: Frame numbers 56 to 400 and flange numbers 55 to 1080

comme il est requis par

Directive Bas Voltage (LVD) CEE 14/35

Directive sur la Compatibilité électromagnétique (EMC) CEE 14/30

Directive sur l'écoconception produits liés à l'énergie (ErP) CEE 19/1781



Motive s.r.l.  
Via Le Ghiselle, 20  
25014 Castenedolo (BS) Italia  
Tel.: +39 030 2677087  
Fax: +39 030 2677125  
motive@motive.it  
Capitale Sociale Euro 50.000  
Reg. Imprese AS n° 73020/2000 - REA 422301  
Cod. Fisc. n° 03550280174  
*Giorgio Bosio*  
**Dott. GIORGIO BOSIO**

N. REA 422301  
Cod. Fisc. e P. IVA 035580280174

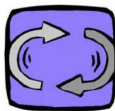

motive

Motive s.r.l.  
Via Le Ghiselle, 20  
25014 Castenedolo (BS)  
Tel.: +39 030 2677087  
Fax: +39 030 2677125  
motive@motive.it



## DECLARATION DE CONFORMITE C<sub>2</sub>



La société Motive S.r.l. sise à Castenedolo - BRESCIA (Italie)

Déclare sous son entière responsabilité, que toute sa gamme de

**moteurs asynchrones électriques triphasés série « DELPHI » et « DELFIRE »**

est réalisée et testé conformément à la normative internationale

- EN60034-1** Rotating Electrical Machines - Part 1: Rating and performance
- EN60034-6** Rotating Electrical Machines - Part 6: Methods of cooling (IC code)
- EN60034-7** Rotating Electrical Machines - Part 7: Classification of Types of Construction, Mounting Arrangements and Terminal Box Position (IM Code)
- EN60034-8** Rotating electrical machines – Part 8: Terminal markings and direction of rotation
- EN60034-25** Rotating electrical machines - Part 25: Guidance for the design and performance of a.c. motors specifically designed for converter supply
- EN60034-2-1** Rotating electrical machines. Standard methods for determining losses and efficiency from tests
- EN60034-30-1** Rotating electrical machines - Part 30: Efficiency classes of single-speed, three-phase, cage-induction motors
- EN50347** General purpose three-phase induction motors having standard dimensions and outputs. Frame numbers 56 to 315 and flange numbers 65 to 740
- EN61000-6-4** Electromagnetic compatibility (EMC) - Part 6: Generic standards - Section 4: Emission standard for industrial environments
- IEC 72-1** Dimensions and output series for rotating electrical machines Part 1: Frame numbers 56 to 400 and flange numbers 55 to 1080

et elle est donc conforme aux arrêtés

LVD Arrêté No. 2573-14  
EMC Arrêté No. 2574-14



Motive s.r.l.  
Via Le Ghiselle, 20  
25014 Castenedolo (BS) - Italy  
Tel.: +39 030 2677087  
Fax: +39 030 2677125  
motive@motive.it  
Capitale Sociale Euro 50.000  
Reg. Imprese n° 172020300-AL REA 42201  
Cod. Fisc. n° 03580280174

Rappresentante legale: Giorgio Bosio

Dot. GIORGIO BOSIO

N. REA 422301  
Cod. Fisc. e P. IVA 03580280174



Motive s.r.l.  
Via Le Ghiselle, 20  
25014 Castenedolo (BS)  
Tel.: +39 030 2677087  
Fax: +39 030 2677125  
motive@motive.it



## Dichiarazione di conformità

La ditta Motive s.r.l. con sede in Castenedolo (BS) - Italia  
dichiara, sotto la sua esclusiva responsabilità,  
che la sua intera gamma di **motori elettrici asincroni monofase serie MONO**  
è costruita in conformità con la seguente normativa internazionale (ult. edizione)

- EN60034-1** Macchine elettriche rotanti - Parte 1: Caratteristiche nominali e di funzionamento
- EN60034-6** Macchine elettriche rotanti - Parte 6: Sistemi di raffreddamento
- EN60034-7** Macchine elettriche rotanti - Parte 7: Classificazione delle forme costruttive e dei tipi di installazione nonché posizione delle morsettiere (Codice IM)
- EN60034-8** Macchine elettriche rotanti - parte 8: Marcatura dei terminali e senso di rotazione
- EN50347** Motori asincroni trifase di uso generale con dimensioni e potenze normalizzate - Grandezze da 56 a 315 e numeri di flangia da 65 a 740
- EN61000-6-4** Compatibilità elettromagnetica (EMC): Parte 6-4: Norme generiche - Emissione per gli ambienti industriali
- IEC 72-1** Dimensions and output series for rotating electrical machines Part 1: Frame numbers 56 to 400 and flange numbers 55 to 1080  
come richiesto dalle Direttive

**BT Bassa Tensione CEE 14/35,**  
**EMC Compatibilità Elettromagnetica CEE 14/30**

Il motore non deve funzionare finché la macchina ove viene assemblato viene dichiarata conforme alla **Direttiva Macchine CEE 06/42**  
NB: la Direttiva Macchine espressamente esclude dal suo campo di applicazione i motori elettrici (Art.1, comma 2)

Il Rappresentante Legale: Giorgio Bosio



Motive s.r.l.  
Via Le Ghiselle, 20  
25014 Castenedolo (BS)  
Tel.: +39 030 2677087  
Fax: +39 030 2677125  
motive@motive.it



## DECLARATION DE CONFORMITE

La société Motive S.r.l. sise à Castenedolo - BRESCIA (Italie)  
déclare sous son entière responsabilité, que toute sa gamme des  
moteurs asynchrones électriques monophasés série « MONO »  
est réalisée conformément à la normative internationale

**EN60034-1** Machines électriques tournantes: caractéristiques désignées et caractéristiques de fonctionnement

**EN60034-6** Machines électriques tournantes : modes de refroidissement

**EN60034-7** Machines électriques tournantes - Partie 7: symbole pour les formes de construction et les dispositions de montage, ainsi que la position de la boîte à bornes (Code IM)

**EN60034-8** Machines électriques tournantes: marques d'extrémités et sens de rotation

**EN60034-25** Machines électriques tournantes – Partie 25: Guide pour la conception et la performance des moteurs à induction à cage spécifiquement conçus pour l'alimentation du convertisseur

**EN50347** Moteurs asynchrones triphasés d'utilisation générale ayant des dimensions et des puissances normalisées – de hauteur d'axe de 56 à 315 et des brides de 65 à 740

**EN61000-6-4** Compatibilité électromagnétique (EMC): Partie 6-4: Normes générales – Emission

**IEC 72-1** Dimensions and output series for rotating electrical machines Part 1: Frame numbers 56 to 400 and frame numbers 55 to 1080

comme il est requis par

Directive Bas Voltage (LVD) CEE 14/35,

Directive sur la Compatibilité électromagnétique (EMC) CEE 14/30

NB: la Directive Machines (MD) 2006/42/CE exclut expressément de son domaine d'application les moteurs électriques (Art.1, alinéa 2)

Le représentant légal : Giorgio Bosio

N. REA 422301  
Cod. Fisc. e P. IVA 03580280174

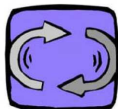

motive

Motive s.r.l.  
Via Le Ghiselle, 20  
25014 Castenedolo (BS)  
Tel.: +39 030 2677087  
Fax: +39 030 2677125  
motive@motive.it



## DECLARATION DE CONFORMITE C<sub>2</sub>



La société Motive S.r.l. sise à Castenedolo - BRESCIA (Italie)  
déclare sous son entière responsabilité, que toute sa gamme de  
moteurs asynchrones électriques monophasés série « MONO »

est réalisée conformément à la normative internationale

- EN60034-1** Machines électriques tournantes: caractéristiques désignées et caractéristiques de fonctionnement
- EN60034-6** Machines électriques tournantes : modes de refroidissement
- EN60034-7** Machines électriques tournantes - Partie 7: symbole pour les formes de construction et les dispositions de montage, ainsi que la position de la boîte à bornes (Code IM)
- EN60034-8** Machines électriques tournantes: marques d'extrémités et sens de rotation
- EN60034-25** Machines électriques tournantes – Partie 25: Guide pour la conception et la performance des moteurs à induction à cage spécifiquement conçus pour l'alimentation du convertisseur
- EN50347** Moteurs asynchrones triphasés d'utilisation générale ayant des dimensions et des puissances normalisées – de hauteur d'axe de 56 à 315 et des brides de 65 à 740
- EN61000-6-4** Compatibilité électromagnétique (EMC): Partie 6-4: Normes générales – Emission
- IEC 72-1** Dimensions and output series for rotating electrical machines Part 1: Frame numbers 56 to 400 and flange numbers 55 to 1080

et elle est donc conforme aux arrêtés

LVD Arrêté No. 2573-14  
EMC Arrêté No. 2574-14



représentant légal : Giorgio Bosio

Motive s.r.l.  
Via Le Ghiselle, 20  
25014 CASTNEDELO (BS) Italia  
Tel.: +39.030.2677087  
Fax: +39.030.2677125  
motive@motive.it  
Capitale Sociale Euro 50.000  
Reg. Imprese n° 72820/2000-ALREA 422001  
Cod. Fisc. n° 03580280174

*Giorgio Bosio*  
/s/ Dott. GIORGIO BOSIO

N. REA 422301  
Cod. Fisc. e P. IVA 03580280174



## СИСТЕМА ДОБРОВОЛЬНОЙ СЕРТИФИКАЦИИ

«Старт»

Зарегистрирована в Едином реестре систем добровольной сертификации Федерального агентства по техническому регулированию и метрологии Российской Федерации (Росстандарт РФ)



ИСПЫТАТЕЛЬНАЯ ЛАБОРАТОРИЯ ОБЩЕСТВО С ОГРАНИЧЕННОЙ ОТВЕТСТВЕННОСТЬЮ ИННОВАЦИОННЫЙ ЦЕНТР «КОЛИБРИ» (ООО ИЦ «КОЛИБРИ»)

109025, г. Москва, 8-й проезд Марьиной Рощи, дом 30, стр. 1,

тел. +7(499) 391-23-57, [inbox@i-sert.ru](mailto:inbox@i-sert.ru)

**АТТЕСТАТ АККРЕДИТАЦИИ № РОСС RU.31857.04И.ЛС0.00063 действителен до 17.06.2022г.**

### ПРОТОКОЛ ИСПЫТАНИЙ № 199-04/2020 от 14.04.2020 года

Место проведения испытаний:	Испытательная лаборатория ООО ИЦ «КОЛИБРИ»
Заявитель:	Общество с ограниченной ответственностью "ПРИВОД ГРАНД РЕДУКТОР". Место нахождения и адрес места осуществления деятельности: Российская Федерация, Смоленская область, 214004, город Смоленск, улица Багратиона, дом 4, офис 46
Наименование продукции:	Электродвигатели (мотор-редукторы) асинхронные трехфазные общепромышленного назначения, рабочее напряжение 220/380В. Модель 56В-2
Изготовитель:	"Motive srl". Место нахождения и адрес места осуществления деятельности по изготовлению продукции: Via Le Ghiselle, 20 25014 Castenedolo (BS), Италия.
Технический регламент:	ТР ТС 004/2011 "О безопасности низковольтного оборудования",
Испытано согласно требованиям:	ТР ТС 004/2011 "О безопасности низковольтного оборудования",
Дата получения образца	31.03.2020г.

*Настоящий протокол испытаний распространяется только на образцы, подвергнутые испытаниям*





## ЕВРАЗИЙСКИЙ ЭКОНОМИЧЕСКИЙ СОЮЗ ДЕКЛАРАЦИЯ О СООТВЕТСТВИИ



**Заявитель** Общество с ограниченной ответственностью "ПРИВОД ГРАНД РЕДУКТОР"

Место нахождения и адрес места осуществления деятельности: Российская Федерация, Смоленская область, 214004, город Смоленск, улица Багратиона, дом 4, офис 46, основной государственный регистрационный номер: 1166733076608, номер телефона: +79203158381, адрес электронной почты: [privodgrand@gmail.com](mailto:privodgrand@gmail.com)

**в лице** Директора Шелеста Александра Иосифовича

**заявляет, что** Электродвигатели (мотор-редукторы) асинхронные трехфазные общепромышленного назначения, рабочее напряжение 220/380В. Модели по приложению № 1, количество листов: 2

**изготовитель** "Motive srl". Место нахождения и адрес места осуществления деятельности по изготовлению продукции: Via Le Ghiselle, 20 25014 Castenedolo (BS), Италия.

Продукция изготовлена в соответствии с Дерективной 2014/35/EU "Низковольтное оборудование".

Код ТН ВЭД ЕАЭС 8501. Серийный выпуск

**соответствует требованиям**

ТР ТС 004/2011 "О безопасности низковольтного оборудования", утвержден Решением Комиссии Таможенного союза от 16 августа 2011 года № 768

**Декларация о соответствии принята на основании**

Протокола испытаний № 199-04/2020 от 14.04.2020 года, выданного Испытательной лабораторией

Общество с ограниченной ответственностью Инновационный центр «Колибри», аттестат

аккредитации РОСС RU.31857.04ИЛС0.00063, сроком действия до 17.06.2022 года.

Схема декларирования 1д

**Дополнительная информация**

ГОСТ 16264.1-2016 Двигатели асинхронные. Часть 1. Общие технические условия. Срок хранения (службы, годности) указан в прилагаемой к продукции товаросопроводительной и/или эксплуатационной документации.

**Декларация о соответствии действительна с даты регистрации по 13.04.2025 включительно**



Шелест Александр Иосифович

(Ф.И.О. заявителя)

**Регистрационный номер декларации о соответствии: ЕАЭС N RU Д-ИТ.НХ37.В.02083/20**

**Дата регистрации декларации о соответствии: 14.04.2020**



## KINGDOM OF SAUDI ARABIA

**Product Conformity Programme**

**Statement for Registration**

PCP Ref.no: **KSA R-205239**

Issued to:

Motive Srl  
Via Artigianale 110/112  
25010 Montirone (BS)  
Italy

Product:

II-06 MOTORS Incl. GEARED MOTORS/DRIVES

Model/Type:

See appendix (1 page/s)

Applicable standards/references:

IEC 60034, IEC 72



Issued by:

Regional Licencing Centre  
Europe, Middle East and Africa  
Intertek Semko AB  
06 November 2009

Pia Östgaard  
Manager

This Statement for Registration is for the exclusive use of Intertek's Client and is provided pursuant to the agreement between Intertek and its Client. Intertek's responsibility and liability are limited to the terms and conditions of the agreement. Intertek assumes no liability to any part, other than to the Client in accordance with the agreement, for any loss, expense or damage occasioned by the use of this Statement for Registration. Only the Client is authorized to permit copying or distribution of this Statement for Registration and then only in its entirety. Any use of the Intertek name for the sale or advertisement of the tested material, product or service must first be approved in writing by Intertek.



## TYPE APPROVAL CERTIFICATE

N. **ELE391318CS001**

This is to certify that the product below is found to be in compliance with the applicable requirements of the RINA Type Approval system.

<b>Description</b>	Asynchronous three-phases electric motors
<b>Type</b>	DELPHI Series
<b>Applicant</b>	Motive S.r.l. Via Le Ghiselle, 20 25014 Castenedolo (BS) Italy
<b>Manufacturing Place</b>	Motive S.r.l. Via Le Ghiselle, 20 25014 Castenedolo (BS) Italy
<b>Testing Standards</b>	RINA Rules for the Classification of Ships – Part C, Ch.2, Sec. 4

Issued in **Genova** on **January 21, 2019**

This certificate is valid until **January 21, 2024**

*Valerio Bonanni*

RINA Services S.p.A.

*Valerio Bonanni*





ZERTIFIKAT ◆ CERTIFICATE ◆ 認證證書 ◆ CERTIFICADO ◆ CERTIFICAT



# CERTIFICATO

Nr. 50 100 1185 - Rev.010

Si attesta che / This is to certify that

IL SISTEMA QUALITÀ DI  
THE QUALITY SYSTEM OF



**MOTIVE S.r.l.**

SEDE LEGALE E OPERATIVA:  
REGISTERED OFFICE AND OPERATIONAL SITE:

**VIA LE GHISSELLE 20**  
**IT - 25014 CASTENDOLO (BS)**

È CONFORME AI REQUISITI DELLA NORMA  
HAS BEEN FOUND TO COMPLY WITH THE REQUIREMENTS OF

**UNI EN ISO 9001:2015**

QUESTO CERTIFICATO È VALIDO PER IL SEGUENTE CAMPO DI APPLICAZIONE  
THIS CERTIFICATE IS VALID FOR THE FOLLOWING SCOPE

**Progettazione e fabbricazione di motori elettrici, riduttori  
meccanici e inverter (IAF 18, 19)**

**Design and manufacture of electrical motors, mechanical gearboxes  
and variable speed drives (IAF 18, 19)**



SGQ N° 049A

Membro degli Accordi di Mutuo Riconoscimento  
EA, IAF e ILAC  
Signatory of EA, IAF and ILAC Mutual  
Recognition Agreements

Per l'Organismo di Certificazione  
For the Certification Body  
**TÜV Italia S.r.l.**

Validità / Validity

Dal / From: **2019-03-19**

Al / To: **2022-03-02**

Data emissione / Issuing Date

**2019-03-19**

*Andrea Coscia*  
**Andrea Coscia**  
Direttore Divisione Business Assurance

**PRIMA CERTIFICAZIONE / FIRST CERTIFICATION: 2001-07-20**  
DATA DI SCADENZA DELL'ULTIMO CICLO DI CERTIFICAZIONE: 2019-03-02  
EXPIRATION DATE OF THE LAST CERTIFICATION CYCLE: 2019-03-02

"LA VALIDITÀ DEL PRESENTE CERTIFICATO È SUBORDINATA A SORVEGLIANZA PERIODICA A 12 MESI E AL RIESAME COMPLETO DEL SISTEMA DI GESTIONE AZIENDALE CON PERIODICITÀ TRIENNALE"

"THE VALIDITY OF THE PRESENT CERTIFICATE DEPENDS ON THE ANNUAL SURVEILLANCE EVERY 12 MONTHS AND ON THE COMPLETE REVIEW OF COMPANY'S MANAGEMENT SYSTEM AFTER THREE-YEARS"

TÜV Italia S.r.l. • Gruppo TÜV SÜD • Via Carducci 125, Pal. 23 • 20099 Sesto San Giovanni (MI) • Italia • www.tuv.it



T01-1401



## Responsabilità del costruttore

Il costruttore declina ogni responsabilità in caso di:

- Uso dei motori contrario alle leggi nazionali sulla sicurezza e sull'infortunistica
- Mancata o errata osservanza delle istruzioni fornite nel presente manuale
- Difetti di alimentazione elettrica
- Modifiche o manomissioni del motore
- Operazioni eseguite da parte di personale non addestrato

La sicurezza dei motori è subordinata anche alla osservanza delle prescrizioni riportate nel presente manuale.

Leggere integralmente le istruzioni ed osservare tutte le precauzioni indicate ed in particolare occorre:

- Operare sempre nei limiti di impiego del motore
- Affidare le manutenzioni a personale qualificato
- Utilizzare esclusivamente ricambi originali

Attenzione! Le istruzioni riportate nel presente manuale non sostituiscono, ma compendiano gli obblighi della legislazione vigente sulle norme di sicurezza

## Manufacturer liability

Motive disclaims all responsibility in case of:

- Use of the motors against national safety law
- Missing or wrong observance of the instructions provided in this manual
- Problems with the power supply
- Motor modifications or tampering
- Operations run by non-trained personnel

The safety in the motors is also due to the observance of the indications provided in this manual.

Read carefully the instructions and keep to all the recommended precautions, too. In particular it is necessary to:

- Work always within the operational limits
- Have maintenance done by qualified personnel
- Use only original spare parts

Warning! The instructions contained in this handbook do not substitute but summarize the duties derived from the regulations in force about safety.



Su [www.motive.it](http://www.motive.it), partendo dal nr di serie nella targa del riduttore, è possibile scaricare il Rapporto del collaudo finale di ogni unità.

On [www.motive.it](http://www.motive.it), using the serial number on the nameplate of the gearbox, it is possible to download the Final Test Report of each unit.





TUTTI I DATI SONO STATI REDATTI E CONTROLLATI CON LA MASSIMA CURA.  
NON CI ASSUMIAMO COMUNQUE NESSUNA RESPONSABILITÀ PER EVENTUALI  
ERRORI OD OMISSIONI.

MOTIVE srl PUÒ A SUO INSINDACABILE GIUDIZIO CAMBIARE IN QUALSIASI  
MOMENTO LE CARATTERISTICHE DEI PRODOTTI VENDUTI.

TOUTES LES DONNÉES ONT ÉTÉ RÉDIGÉES ET CONTRÔLÉES SOIGNEUSEMENT.  
NOUS DÉCLINONS TOUTE RESPONSABILITÉ QUANT AUX ERREURS OU OMISSIONS.  
MOTIVE srl PEUT CHANGER À TOUT MOMENT LES CARACTÉRISTIQUES DE SES  
PRODUITS.



**PER MOTORI ATEX, VEDI L'INTEGRAZIONE  
"ADDENDUM"**



**POUR MOTEURS ATEX, VOIR LE FICHER  
"ADDENDUM" QUI COMPLET CE MANUEL**

**MADE IN ITALY**

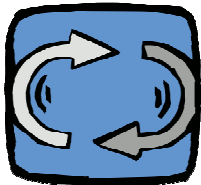

**motive**



Motive srl

[www.motive.it](http://www.motive.it)

[motive@motive.it](mailto:motive@motive.it)

Tel: +39 030 2677087

Fax: +39 030 2677125

